

**INFORMAZIONI GENERALI**

Il presente catalogo serve per richiedere con esattezza le parti di ricambio

Nelle ordinazioni indicare:

- 1) il numero di codice dei particolari seguito dalla descrizione;
- 2) il colore per i pezzi verniciati o comunque colorati;
- 3) il numero di matricola del motociclo, stampigliato sul canotto di sterzo.

Le indicazioni destra e sinistra si riferiscono ai lati del veicolo rispetto al senso di marcia.

**GENERAL INFORMATION**

The present spare parts list enables one to order exactly the right spare parts.

When ordering specify:

- 1) the part's code number followed by its description;
  - 2) indicate colour for painted or coloured parts;
  - 3) the motorcycle's serial number, stamped on the steering head.
- References to right and left apply to the vehicle in terms of its direction of movement.

**INFORMATIONS GENERALES**

Ca catalogue permet de commander correctement les pièces de rechange. Les commandes doivent être passées en indiquant:

- 1) le numéro de code des pièces détachées suivi de leur description;
- 2) le couleur des pièces peintes ou colorés;
- 3) le matricule de la moto, estampillé sur la tige du guidon.

Droite et gauche sont les côtés du véhicule par rapport au sens de la marche.

**ALLGEMEINE HINWEISE**

Dieser Ersatzteilkatalog dient zur genauen Angabe der Teile bei Ersatzteilbestellungen.

Bei Ersatzbestellung ist folgendes anzugeben:

- 1) Die Bestellnummer der Ersatzteile mit der entsprechenden Beschreibung;
  - 2) Farbe für lackierte und farbige Teile angeben;
  - 3) Die Seriennummer des Motorrads, die am Lenkrohr eingepreßt ist.
- Die Angaben rechts und links beziehen sich auf das Fahrzeug in Fahrrichtung.

**INFORMACIONES GENERALES**

El presente catálogo sirve para pedir con exactitud las partes de recambio.

En los pedidos se debe indicar:

- 1) el número de código de la parte y a continuación la descripción;
- 2) el color para las piezas barnizadas o coloreadas;
- 3) el número de matrícula de la motocicleta, estampado en el tubo de dirección.

Las indicaciones derecha e izquierda se refieren a los lados del vehículo respecto del sentido de marcha.

**NOTE - LIST - NOTES - NOTE - NOTAS:**

- A** : In alternativa - In alternative - En alternative  
Wahlweise - En alternativa
- C** : Modello CR- CR model - Modèle CR - Modell CR  
Modélo CR
- D** : In dotazione - To issue - En necessaire  
Ausrüstungsteile - En dotación
- E** : Ad esaurimento - To fell out - A' finir - Erschöpfung  
A agotamiento
- F** : Fornire assieme - Supply unitedly - Fournir ensemble  
Wird zusammen geliefert - Equipar juntos
- N** : Non fornito - Not supplied - Ne pas fournit  
Keine Gelieferende - No equiparado
- R** : A richiesta - Upon request - Sur demande  
Auf anfrage - Bajo pedido
- S** : Di serie - Supplied - De série - Standard - De serie
- U** : Solo per WR/ U.S.A. - Only for WR/ U.S.A.  
Solement pour WR/ U.S.A.- Nur für WR/ U.S.A.  
Solo por WR/ U.S.A.
- X** : Non per U.S.A. - Not for U.S.A. - Ne pas pour U.S.A.  
Keine für U.S.A. - No por U.S.A.
- Y** : Non per CR - Not for CR - Ne pas pour CR  
Keine für CR - No por CR
- XBR** : Non per Brasile- Not for Brazil - Ne pas pour Brasile  
Keine für Brasilien - No por Brasil
- W** : Modello WR- WRmodel - Modèle WR- Modell WR  
Modélo WR
- Z** : n° denti, number of teeth, numéro dents, Zähne nummer,  
número dientes
- (&), (@) : Montati assieme- Assembled together

- A** : Austria, Austria, Autriche, Österreich, Austria
- AUS** : Australia, Australia, Australie, Australien, Australia
- B** : Belgio, Belgium, Belgique, Belgien, Bélgica
- BR** : Brasile, Brazil, Brasile, Brasilien, Brasil
- CDN** : Canada, Canada, Canada, Kanada, Canadá
- CH** : Svizzera, Switzerland, Suisse, Schweizer, Suiza
- D** : Germania, Germany, Allemagne, Deutschland, Alemania
- E** : Spagna, Spain, Espagne, Spanien, España
- F** : Francia, France, France, Frankreich, Francia
- GB** : Gran Bretagna, Great Britain, Grand Bretagne  
Groos Britan, Gran Bretaña
- I** : Italia, Italy, Italie, Italien, Italia
- J** : Giappone, Japan, Japon, Japan, Japón
- SF** : Finlandia, Finald, Finlande, Finnland, Finlandia
- USA** : Stati Uniti d'America, United States of America  
Etats Units d'Amerique,  
Vereinigte Staaten von Amerika, Estados Unidos

Il n° di matricola iniziale del modello **WR 125/2005** è **ZCG2H00AA4V003000**  
Il n° di matricola iniziale del modello **CR 125/2005** è **ZCG2H00AA4V053000**

The initial serial number for the **WR 125/2005** model is **ZCG2H00AA4V003000**  
The initial serial number for the **CR 125/2005** model is **ZCG2H00AA4V053000**

Le matricule initial du modèle **WR 125/2005** est **ZCG2H00AA4V003000**  
Le matricule initial du modèle **CR 125/2005** est **ZCG2H00AA4V053000**

Die Seriennummer des Modells **WR 125/2005** beginnt mit **ZCG2H00AA4V003000**  
Die Seriennummer des Modells **CR 125/2005** beginnt mit **ZCG2H00AA4V053000**

El n° de matrícula inicial de la motocicleta **WR 125/2005** es **ZCG2H00AA4V003000**  
El n° de matrícula inicial de la motocicleta **CR 125/2005** es **ZCG2H00AA4V053000**

Dati indicativi soggetti a modifiche senza impegno di preavviso.  
All data are subject to modification without prior notice.  
Données indicatif sujet a modifications sans obligation de préavis.  
Anderungen Vorbehalten.  
Datos indicativos sujetos a modificaciones sin compromiso de preaviso.

Tavola Drawing Table Bild Tabla	Denominazione	Description	Designation	Bezeichnung	Denominacion	Pagina Page Page Seite Paja
1	ATTREZZI DI ASSISTENZA, MANUALI E CATALOGHI	SERVICE TOOLS, MANUALS AND CATALOGS	OUTILS D'ASSISTANCE, MANUELS ET CATALOGUES	HILFAUSRUSTUNG, HANDBUCH UND KATALOG	HERRAMIENTAS DE ASISTENCIA, MANUALES Y CATALOGOS	11
2	TESTA, CILINDRO, PISTONE, MANOVELLISMO	CYLINDER HEAD, CYLINDER, PISTON, CRANKSHAFT	CULASSE, CYLINDRE, PISTON, VILEBREQUIN	ZYLINDERKOPF, ZYLINDER, KOLBEN, KURBELWELLE	CULATA, CILINDRO, PISTON, PALANCAS	13
3	H.T.S.	H.T.S.	H.T.S.	H.T.S.	H.T.S.	19
4	RAFFREDDAMENTO	COOLING SYSTEM	REFROIDISSEMENT	WASSERKÜHLUNG	ENFRIAMIENTO	23
5	BASAMENTO	CRANKCASE	CARTER	GEHAUSE	BANCADA	25
6	COPERCHI BASAMENTO	CRANKCASE COVERS	COUVERCLES CARTER	GEHAUSEDECKEL	TAPA BANCADA	29
7	FRIZIONE, TRASM. PRIMARIA	CLUTCH, PRIMARY DRIVE	EMBAYAGE, TRANSMISS. PRIMARIE	KUPPLUNG, ERSTERANTRIEB	ENBRAGUE, TRANSM. PRIMARIA	31
8	CAMBIO	TRANSMISSION	BOITE DE VITESSE	WECHSELGETRIEBE	CAMBIO	33
9	COMANDO CAMBIO	SHIFTER	COMMANDE DE VITESSE	GANGSCHALTUNG	MANDO CAMBIO	37
10	PARTE ELETTRICA (WR)	ELECTRIC PART (WR)	PARTIE ELECTRIQUES (WR)	ELEKTRISCHETEILE (WR)	PARTE ELECTR. (WR)	39
10A	PARTE ELETTRICA (CR)	ELECTRIC PART (CR)	PARTIE ELECTRIQUES (CR)	ELEKTRISCHETEILE (CR)	PARTE ELECTR. (CR)	41
11	AVVIAMENTO A PEDALE	KICK STARTER	PEDAL DE MISE EN MARCHÉ	ANLASSER	PUESTA EN MARCHA A PEDAL	43
12	CARBURATORE	CARBURETOR	CARBURATEUR	VERGASER	CARBURADOR	45
13	FILTRO ARIA	AIR FILTER	FILTRE AIRE	AIRFILTER	FILTRO DE AIRE	49
14	TELAIO, PEDANE	FRAME, FOOT RESTS	CADRE, REPOSE PIEDS	RAHMEN, FUSSBRETT	BASTIDOR, REPOSAPIES	51
15	SOSPENSIONE ANTERIORE	FRONT FORK ASSEMBLY	SUSPENSION AVANT	VORDERTELESKOPGABEL	SUSPENSION DELANTERA	55
16	FORCELLONE	SWING ARM	FOURCHE	GABEL	HORQUILLA	61
16A	LEVERAGGI SOSPENSIONE POSTERIORE	REAR SUSPENSION LINKAGE	LEVIER SUSPENSION ARRIERE	HEBELWERK HINTERHAUFHANGUNG	PALANCA SUSPENSION TRASERA	65
16B	AMMORTIZZATORE POSTERIORE	REAR SHOCK ABSORBER	AMMORTISSEUR ARRIÈRE	HINTERSTOSSDAMPFER	AMORTIGUADOR TRASERO	67
17	MANUBRIO E COMANDI	HANDLEBAR AND CONTROLS	GUIDON ET COMMANDES	LENKER UND STEUERORGANE	MANILLAR Y MANDOS	69
18	FRENO IDRAULICO POSTERIORE	REAR HYDRAULIC BRAKE	FREIN HYDRAULIQUE ARRIERE	HINTERBREMSE	FRENO HIDRAULICO TRASERO	71
19	PANNELLI LATERALI, PARAFANGHI, SELLA	SIDE PANELS, FENDERS, SEAT	PANNEAU, GARDE-BOUES , SIEGE	STREIFEN, KOTFLUGEL, SATTEL	PANELES, GUARDABARROS, SILLIN	75
20	SERBATOIO CARBURANTE, CONVOGIATORI	GAS TANK, PANELS	RESERVOIR CARBURANT, FLANCS	KRAFTSTOFFBEHALTER, FLANKE	DEPOSITO GASOLINA, LATERALES	79
21	SCARICO	EXHAUST SYSTEM	TUYAU D'ÉCHAPPEMENT	AUSPUFFROHR	TUBO DE ESCAPE	81
22	FRENO IDRAULICO ANTERIORE	FRONT HYDRAULIC BRAKE	FREIN HYDRAULIQUE AVANT	VORTERBREMSE	FRENO HIDRAULICO DELANTERO	83
22A	RUOTA ANTERIORE	FRONT WHEEL	ROUE AVANT	VORTERRAD	RUEDA DELANTERA	87
23	RUOTA POSTERIORE	REAR WHELL	ROUE ARRIERE	HINTERRAD	RUEDA TRASERA	89
24	STRUMENTO DIGITALE (WR)	DIGITAL INSTRUMENT (WR)	INSTRUMENT DIGITAL (WR)	DIGITAL TACHOMETER (WR)	INSTRUMENTO DIGITAL (WR)	93

Tavola Drawing Table Bild Tabla	Denominazione	Description	Designation	Bezeichnung	Denominacion	Pagina Page Seite Paja
25	IMPIANTO ELETTRICO, PORTATARGA, PORTAFARO ANTERIORE (WR)	ELECTRIC SYSTEM, PLATE HOLDER, HEADLAMP FAIRING (WR)	INSTALLATION ELECT.,PORTE-BALAI, DOME PORTE PHARE (WR)	ELEKTR. ANLAGE, SCHILDTRAEGER, HUBE SCHEINWI- HALTER (WR)	INSTALAC. ELECT., PORTA-MATRICULA CASQUETE PORTAFARO (WR)	95
26	INDICATORI DI DIREZIONE, AVVISATORE ACUSTICO (WR)	BLINKERS, HORN (WR)	CLIGNOTANTS, SIGNAL ACOUSTIQUE (WR)	BLINKERS, HUPE (WR)	INTERMITENTES, AVISADOR ACUSTICO (WR)	99
27	KIT TRASFORMAZIONE "ENDURO" (WR- U.S.A.)	"ENDURO" TRANSFORMATION KIT (WR- U.S.A.)	SET TRANSFORMATION "ENDURO" (WR- U.S.A.)	KIT TRANSFORMATION "ENDURO" (WR- U.S.A.)	KIT TRANSFORMATION "ENDURO" R- U.S.A.) (WR- U.S.A.)	101
28	DECALCOMANIE (WR)	TRANSFERS (WR)	DECAL. (WR)	ABZIEHBILD (WR)	CALCOMANIA (WR)	105
29	DECALCOMANIE (CR - WR U.S.A.)	TRANSFERS (CR - WR U.S.A.)	DECAL. (CR - WR U.S.A.)	ABZIEHBILD (CR - WR U.S.A.)	CALCOMANIA (CR - WR U.S.A.)	107
-	INDICE NUMERICO PROGRESSIVO	NUMERICAL INDEX	INDEX NUMERIQUE	NUMMERNVERZEICHNIS	ÍNDICE NUMÉRICO PROGRESÍVO	108

Tavola - Drawing - Table - Bild - Tabla

1

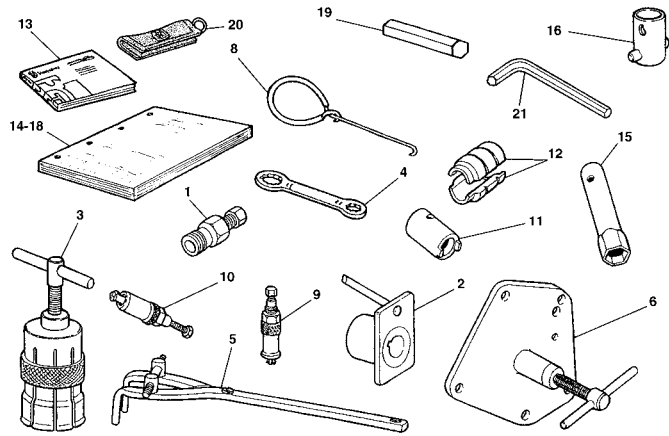

Pagina - Page - Page - Seite - Paja

10

Tavola - Drawing - Table - Bild - Tabla

2

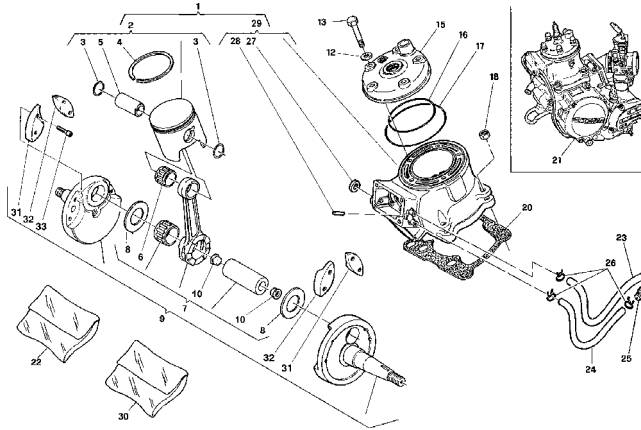

Pagina - Page - Page - Seite - Paja

12

Tavola - Drawing - Table - Bild - Tabla

3

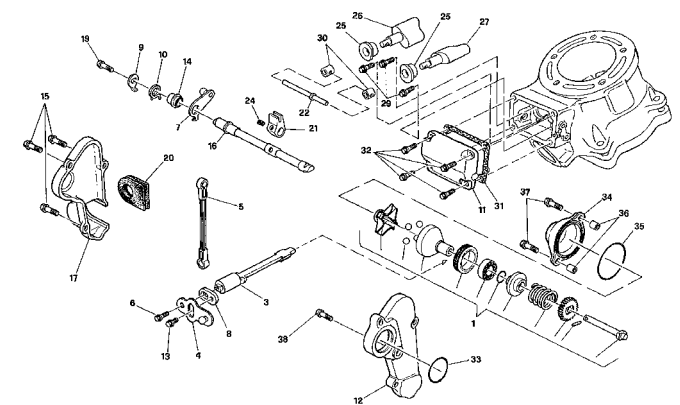

Pagina - Page - Page - Seite - Paja

18

Tavola - Drawing - Table - Bild - Tabla

4

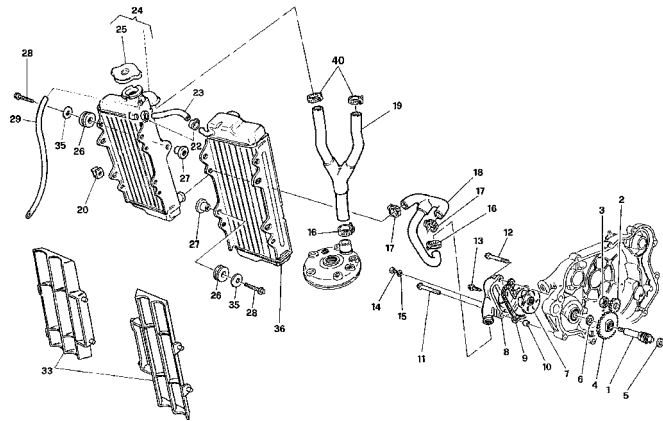

Pagina - Page - Page - Seite - Paja

22

Tavola - Drawing - Table - Bild - Tabla

5

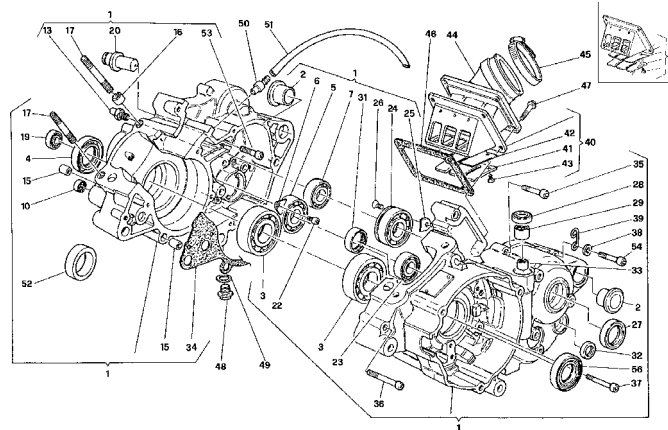

Pagina - Page - Page - Seite - Paja

24

Tavola - Drawing - Table - Bild - Tabla

6

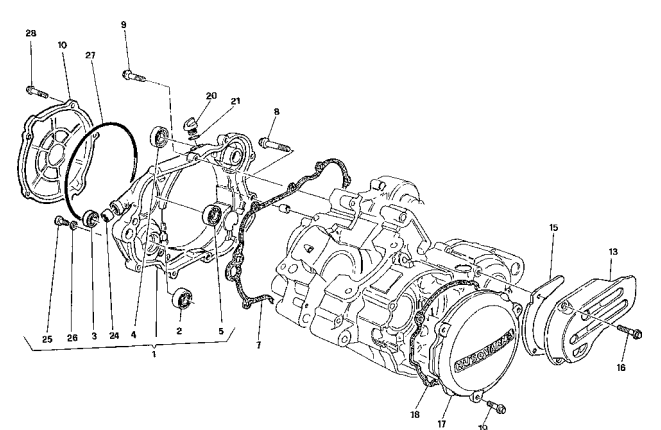

Pagina - Page - Page - Seite - Paja

28

Tavola - Drawing - Table - Bild - Tabla

7

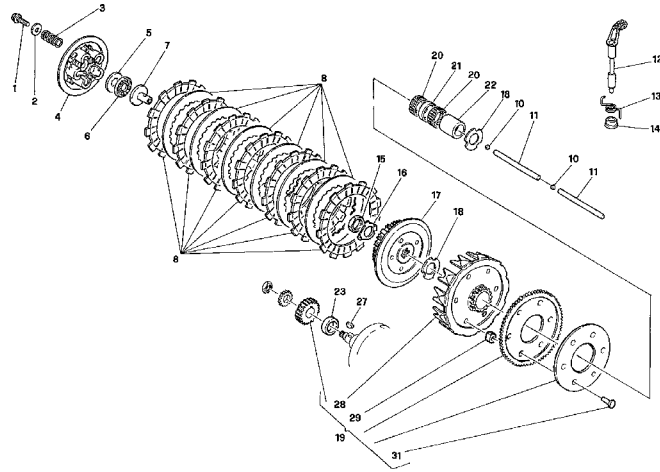

Pagina - Page - Page - Seite - Paja

30

Tavola - Drawing - Table - Bild - Tabla

8

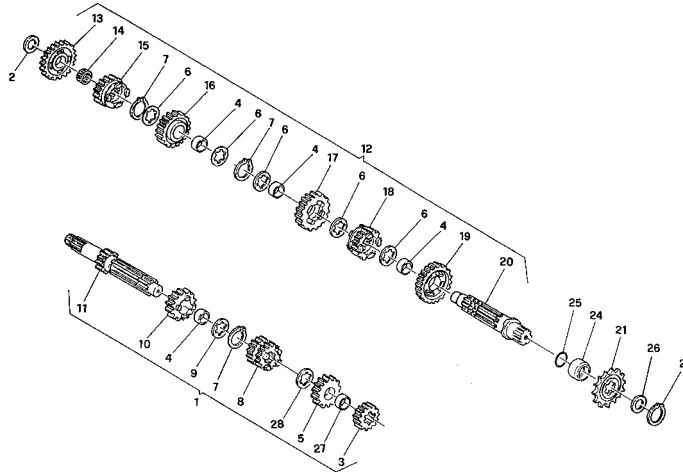

Pagina - Page - Page - Seite - Paja

32

Tavola - Drawing - Table - Bild - Tabla

9

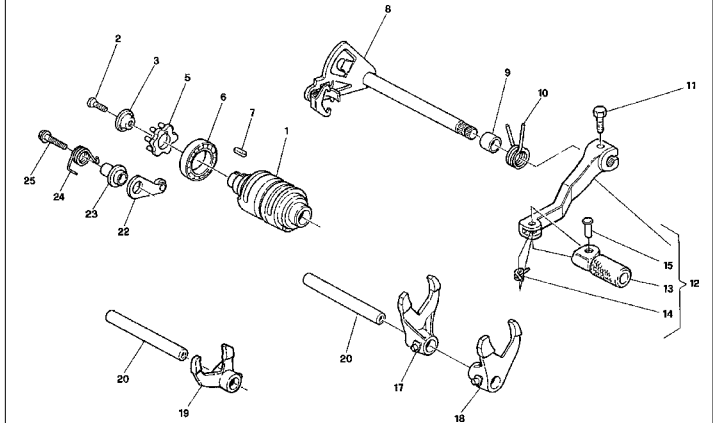

Pagina - Page - Page - Seite - Paja

36

Tavola - Drawing - Table - Bild - Tabla

10

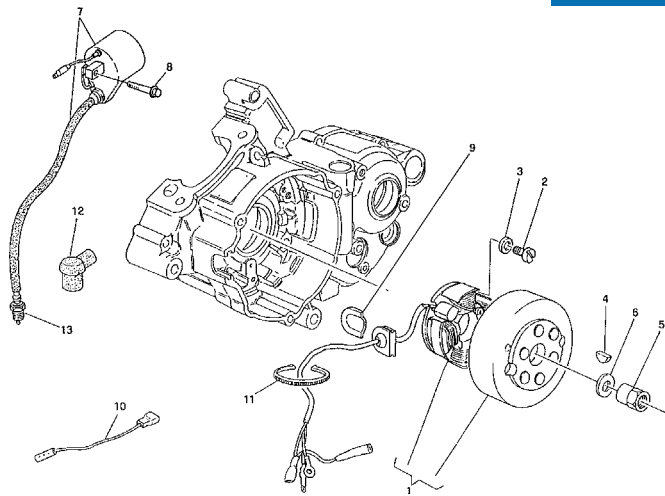

Pagina - Page - Page - Seite - Paja

38

Tavola - Drawing - Table - Bild - Tabla

10A

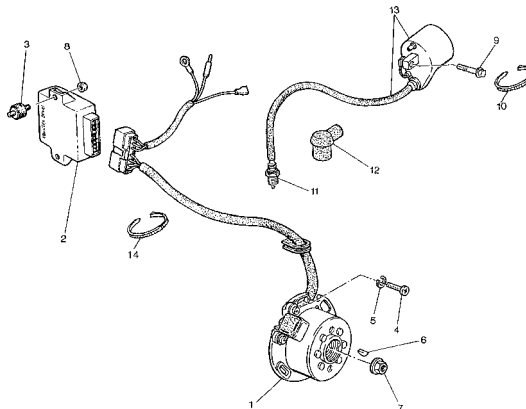

Pagina - Page - Page - Seite - Paja

40

Tavola - Drawing - Table - Bild - Tabla

11

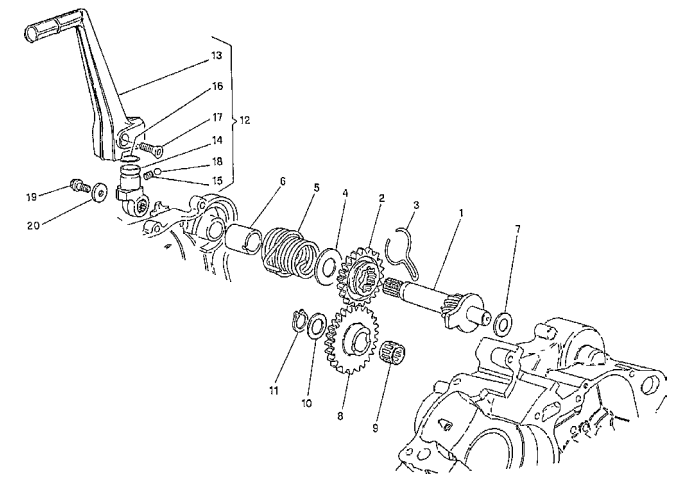

Pagina - Page - Page - Seite - Paja

42

Tavola - Drawing - Table - Bild - Tabla

12

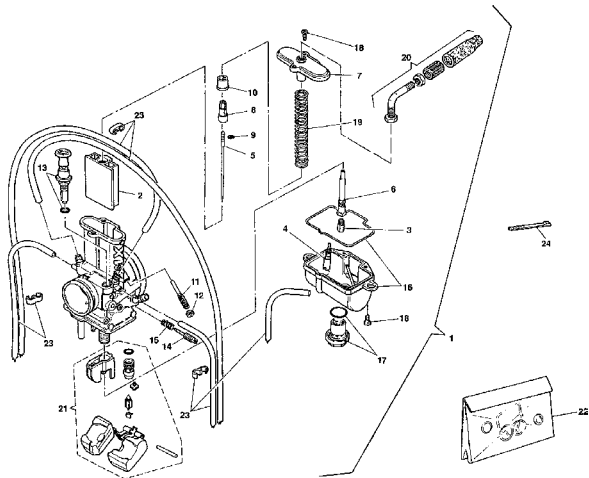

Pagina - Page - Page - Seite - Paja

44

Tavola - Drawing - Table - Bild - Tabla

13

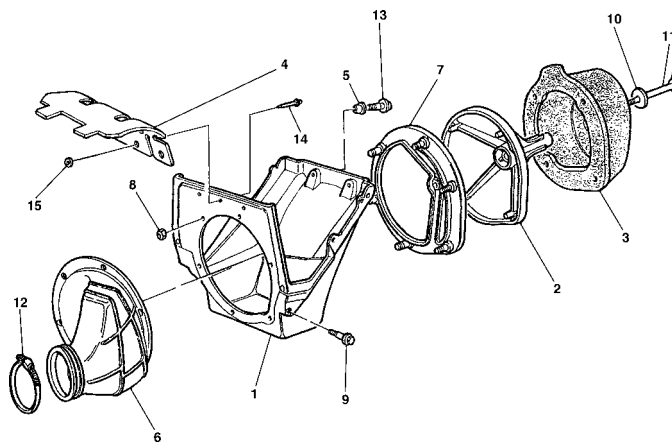

Pagina - Page - Page - Seite - Paja

48

Tavola - Drawing - Table - Bild - Tabla

14

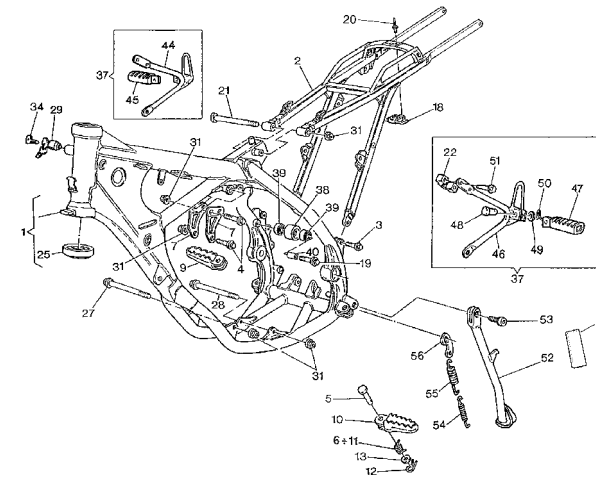

Pagina - Page - Page - Seite - Paja

50

Tavola - Drawing - Table - Bild - Tabla

15

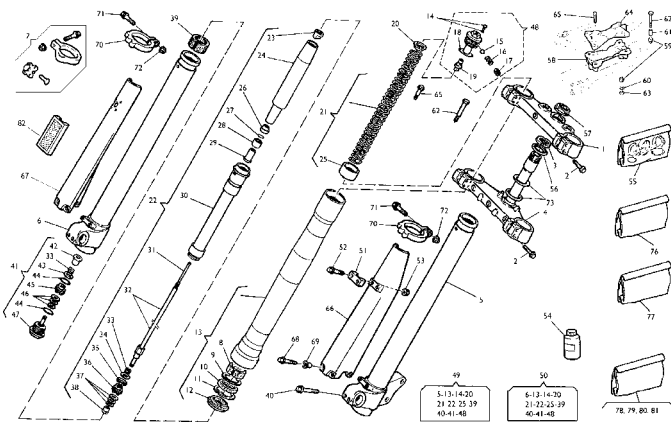

Pagina - Page - Page - Seite - Paja

54

Tavola - Drawing - Table - Bild - Tabla

16

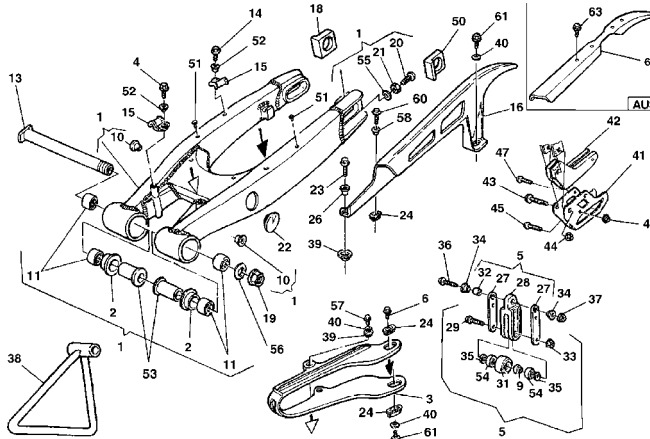

Pagina - Page - Page - Seite - Paja

60

Tavola - Drawing - Table - Bild - Tabla

16A

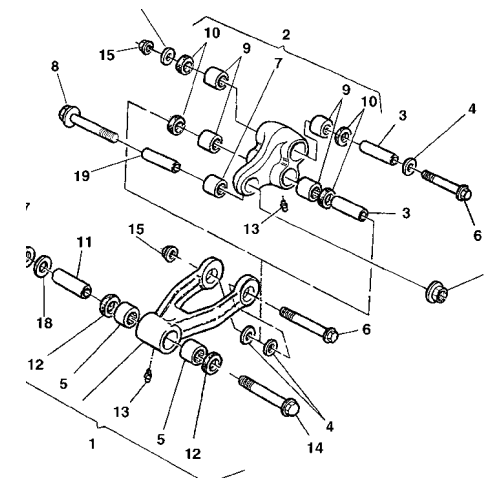

Pagina - Page - Page - Seite - Paja

64



Tavola - Drawing - Table - Bild - Tabla

16B

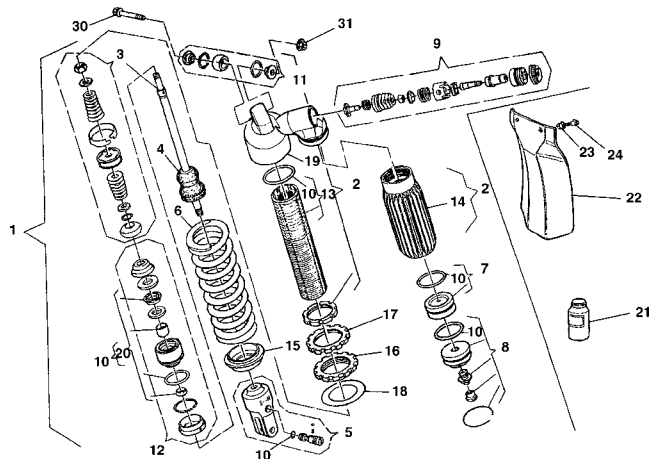

Pagina - Page - Page - Seite - Paja

66

Tavola - Drawing - Table - Bild - Tabla

17

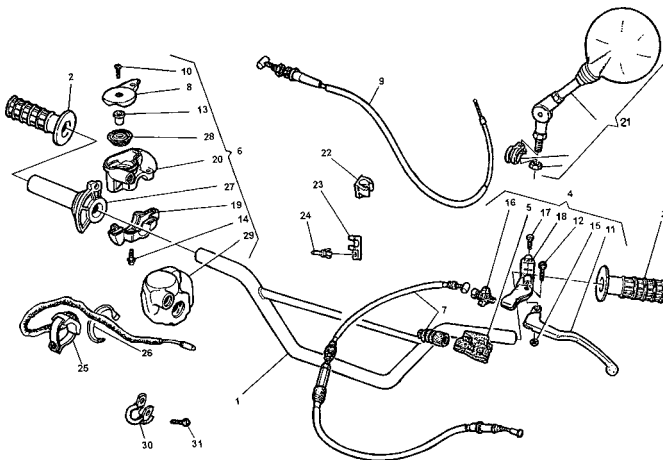

Pagina - Page - Page - Seite - Paja

68

Tavola - Drawing - Table - Bild - Tabla

18

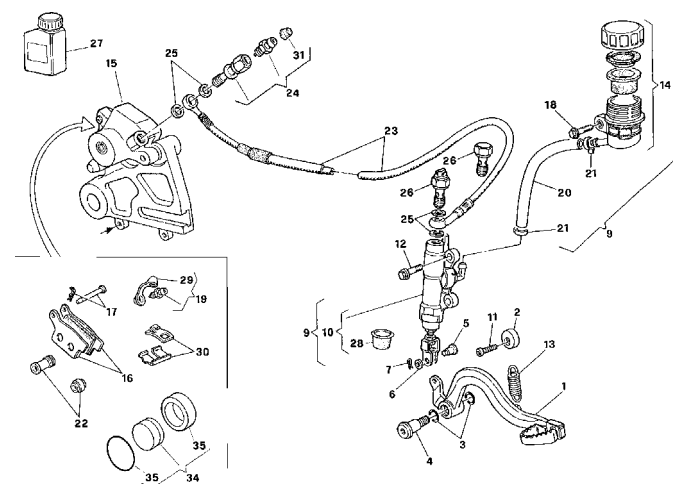

Pagina - Page - Page - Seite - Paja

70

Tavola - Drawing - Table - Bild - Tabla

19

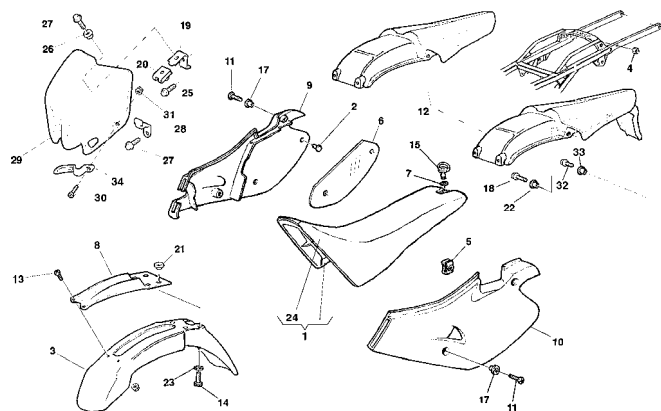

Pagina - Page - Page - Seite - Paja

74

Tavola - Drawing - Table - Bild - Tabla

20

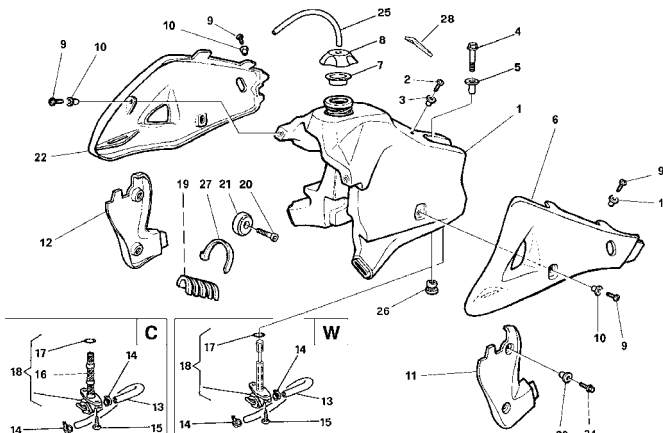

Pagina - Page - Page - Seite - Paja

78

Tavola - Drawing - Table - Bild - Tabla

21

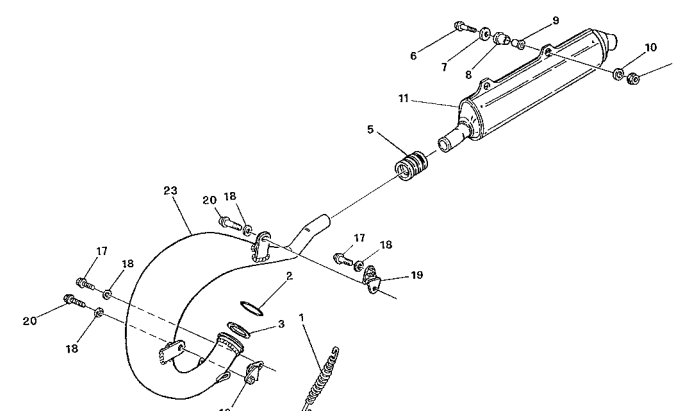

Pagina - Page - Page - Seite - Paja

80

Tavola - Drawing - Table - Bild - Tabla

22

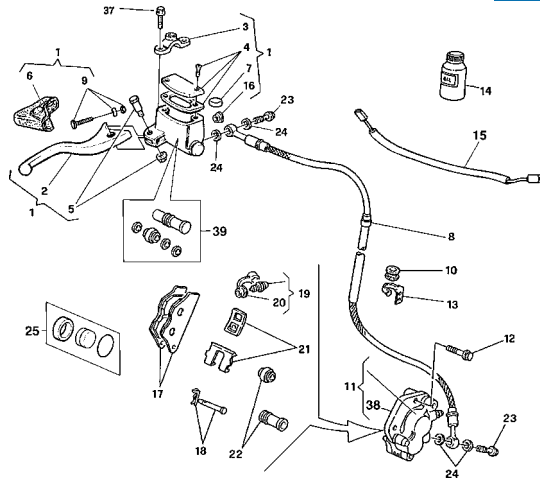

Pagina - Page - Page - Seite - Paja

82

Tavola - Drawing - Table - Bild - Tabla

22A

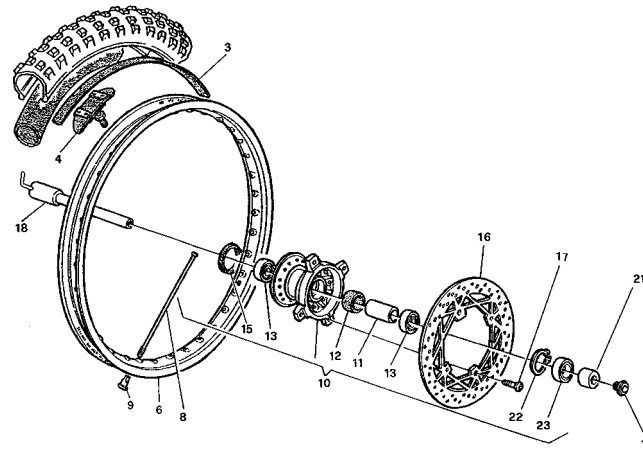

Pagina - Page - Page - Seite - Paja

86

Tavola - Drawing - Table - Bild - Tabla

23

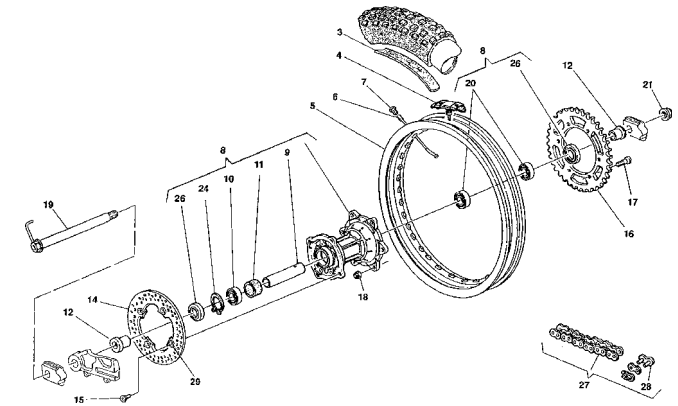

Pagina - Page - Page - Seite - Paja

88

Tavola - Drawing - Table - Bild - Tabla

24

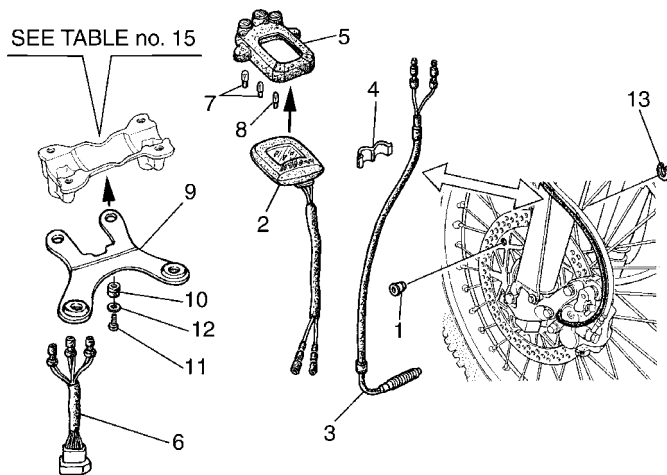

Pagina - Page - Page - Seite - Paja

92

Tavola - Drawing - Table - Bild - Tabla

25

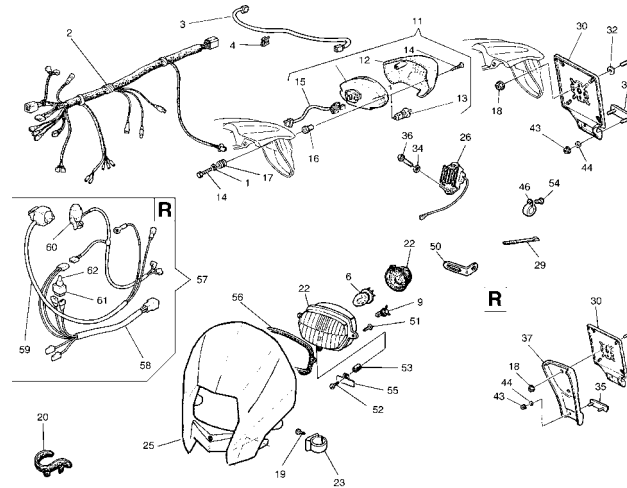

Pagina - Page - Page - Seite - Paja

94

Tavola - Drawing - Table - Bild - Tabla

26

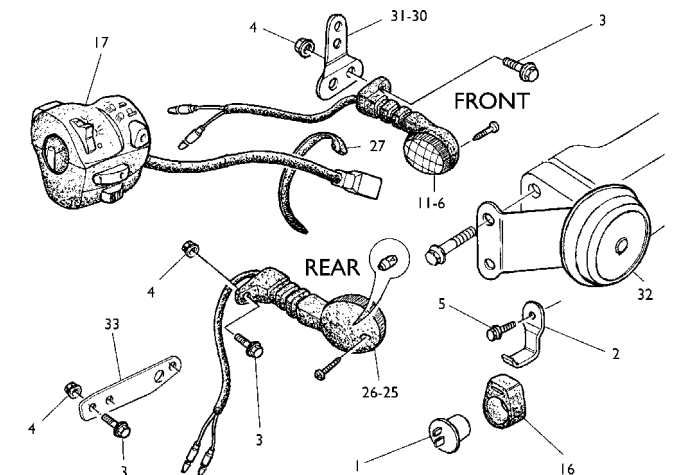

Pagina - Page - Page - Seite - Paja

98



Tavola - Drawing - Table - Bild - Tabla

27

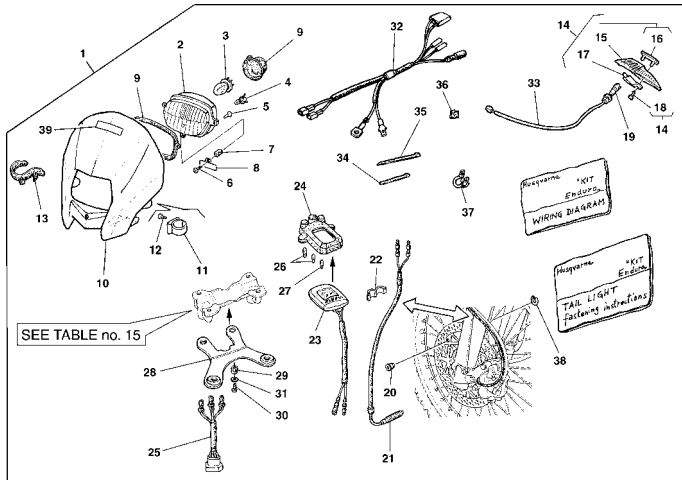

Pagina - Page - Page - Seite - Paja

100

Tavola - Drawing - Table - Bild - Tabla

28



Pagina - Page - Page - Seite - Paja

104

Tavola - Drawing - Table - Bild - Tabla

29



Pagina - Page - Page - Seite - Paja

106

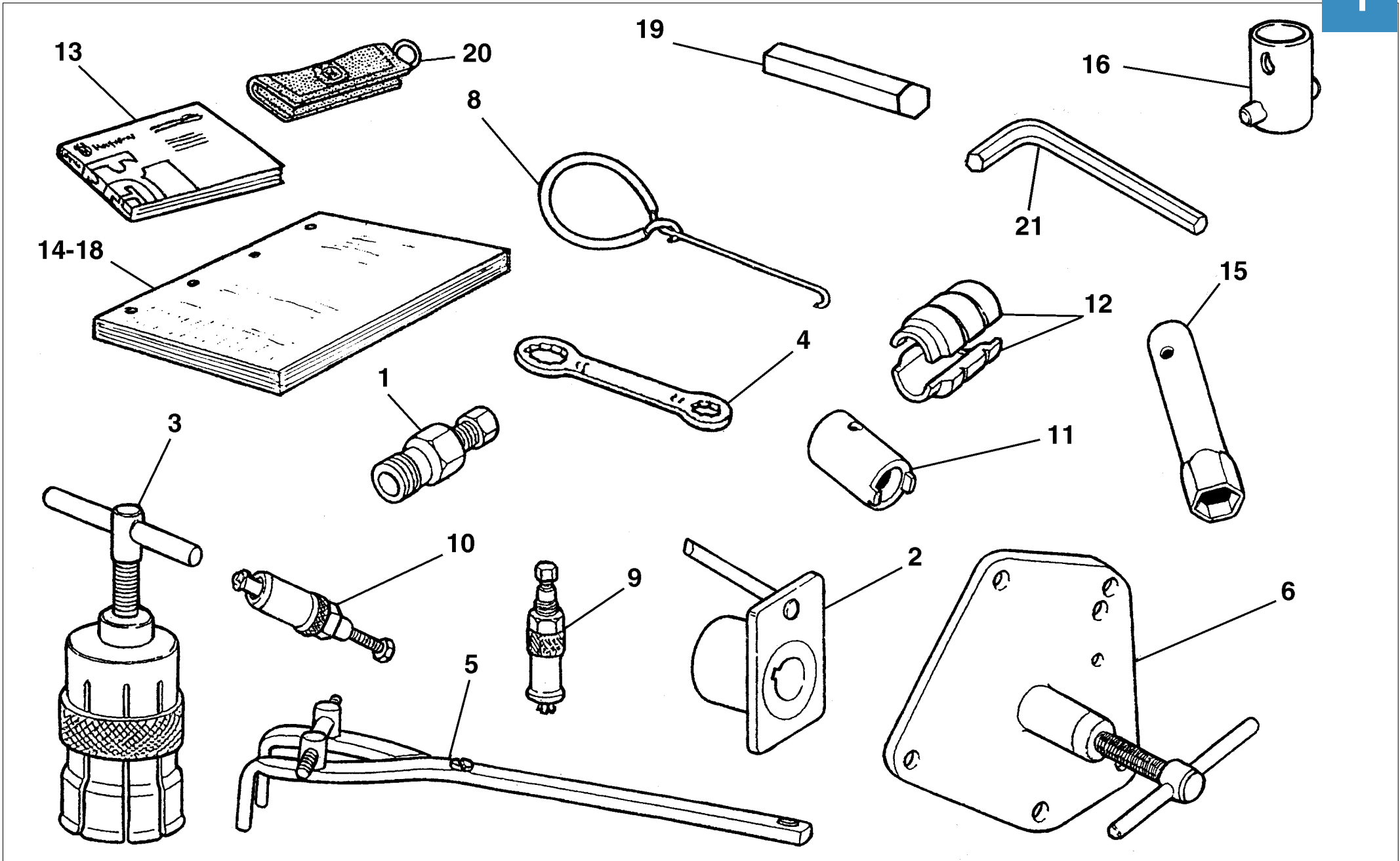

Note Notes Notas	Pos. No. Index Pos.	N. Cod. Code No. Nr. Code Code Nr N. Cod.	Q.tà Q.ty Q.te M.ge C.ad	DENOMINAZIONE	NAME	DESIGNATION	BESHREIBUNG	DENOMINACION	Validità Validity Validité Gültig Validez
WU	1	8000 60516	1	Estrattore volano	Flywheel extractor	Extracteur pour volant	Auszieher für Schwungrad	Extractor volante	
C	1	8000 46613	1	Estrattore volano	Flywheel extractor	Extracteur pour volant	Auszieher für Schwungrad	Extractor volante	
WU	2	8000 86950	1	Attrezzo controllo fase accens.	Ignition control tool	Outil pour surveillance allumage	Werkzeug zur Kontrolle der Zündung	Herramienta control fase encendido	
C	2	8000 79831	1	Attrezzo controllo fase accens.	Ignition control tool	Outil pour surveillance allumage	Werkzeug zur Kontrolle der Zündung	Herramienta control fase encendido	
	3	8000 89030	1	Estrattore per cuscinetto albero motore	Crankshaft bearing extractor	Extracteur pour roulement vilebrequin	Auszieher für Antriebswellelager	Extractor coijnete cigüeñal	
D	4	8000 66802	1	Chiave poligonale	Wrench	Cléf	Schlüssel	Liave	
	5	8000 79015	1	Chiave per mozzo frizione	Clutch hub retaining wrench	Cléf arrêt moyeu embrayage	Schlüssel Radnabe	Liave cubo friccion	
	6	8000 79016	1	Attrezzo sep. semicarter e smont. albero motore	Crankcase splitting tool and crankshaft disassembly	Outil pour demontage carters et vilebrequin	Werkzeug für Trennung Gehäusehälfte und	Herramienta semi-carter	
	8	1519 84701	1	Gancio per molle	Hook	Crochet	Haken	Gancho	
	9	8000 43824	1	Estrattore per cuscinetti a rullini rinvio comando valvola, cuscinetto pompa acqua e comando valvola	Puller, exhaust valve layshaft needle bearings, water pump shaft ball bear. and exhaust valvedrive regulator ball bear.	Extracteur pour coquillé à aiguille renvoi com. soupape, palier pompe et renvoi com. soupape	Werkzeug für Rollenlager, Vorgelege, Ventilsteuerung Lager, Wasserpumpe und, Vorgelege	Extractor cijnete de rulos mando valvula y bomba agua	
	10	8000 43823	1	Estrattore cuscinetto a rullini albero pompa olio	Needle bearing oil pump shaft extractor	Extrac. pour roulement arbre pompe à huile	Auszieher für Nadelkäfig Oelpumpenwelle	Extrac. cijnete de rodillos eje bomba aceite	
	11	8000 91289	1	Attrezzo blocca cartuccia	Pumping retainer	Arret pompage	Klammer pumpen	Broche bombeadora	
	12	8000 91288	1	Introduttore MIM	Jaw	Machoire	Zusatzbacke	Tenaza	
D	13	8000 A4438	1	Libr. uso e manutenzione	Owner's manual	Emploi d'entretien	Betriebsanleitung	Manuàl uso y manten.	
R	14	8000 A4439	1	Manuale di officina	Workshop manual	Manuel d'atelier	Werkstatthandbuch	Manual de Oficina	
D	15	8000 70836	1	Chiave candela	Spark plug wrench	Cléf bougie	Zündkerzeschlüssel	Llave bujia	
D	16	8000 96997	1	Chiave perno ruota anteriore	Front wheel axle wrench	Cléf pivot roue avant	Vorterrad bolzen schlüssel	Llave perno rueda delantera	
R	18	8000 A4440	1	Catalogo PARTI DI RICAMBIO	SPARE PARTS catalog	Catalogue PIECES DE RECHANGE	ERSATZTEILKATALOG	Catalogo PIEZAS DE REPUESTO	
D	19	8000 56920	1	Chiave esagonale per vite perno ruota anteriore	Front wheel axle screw Allen wrench	Cléf à douille pour vis de pivot roue avant	Sechs Kantschlüssel für Vorderradbolzen schraube	Llave hexagonal por tornillo perno rueda delantera	
DY	20	8000 97615	1	Porta chiavi	Key-ring	Porte-clefs	Schlüsselring	Llavero	
Y	21	8000 98431	1	Chiave per viti antimanomissione	"Antitampering"screw wrench	Clef pour vis "Antitampering"	"Antitampering" Schraubeschlüssel	Llave por tornillos "Antitampering"	

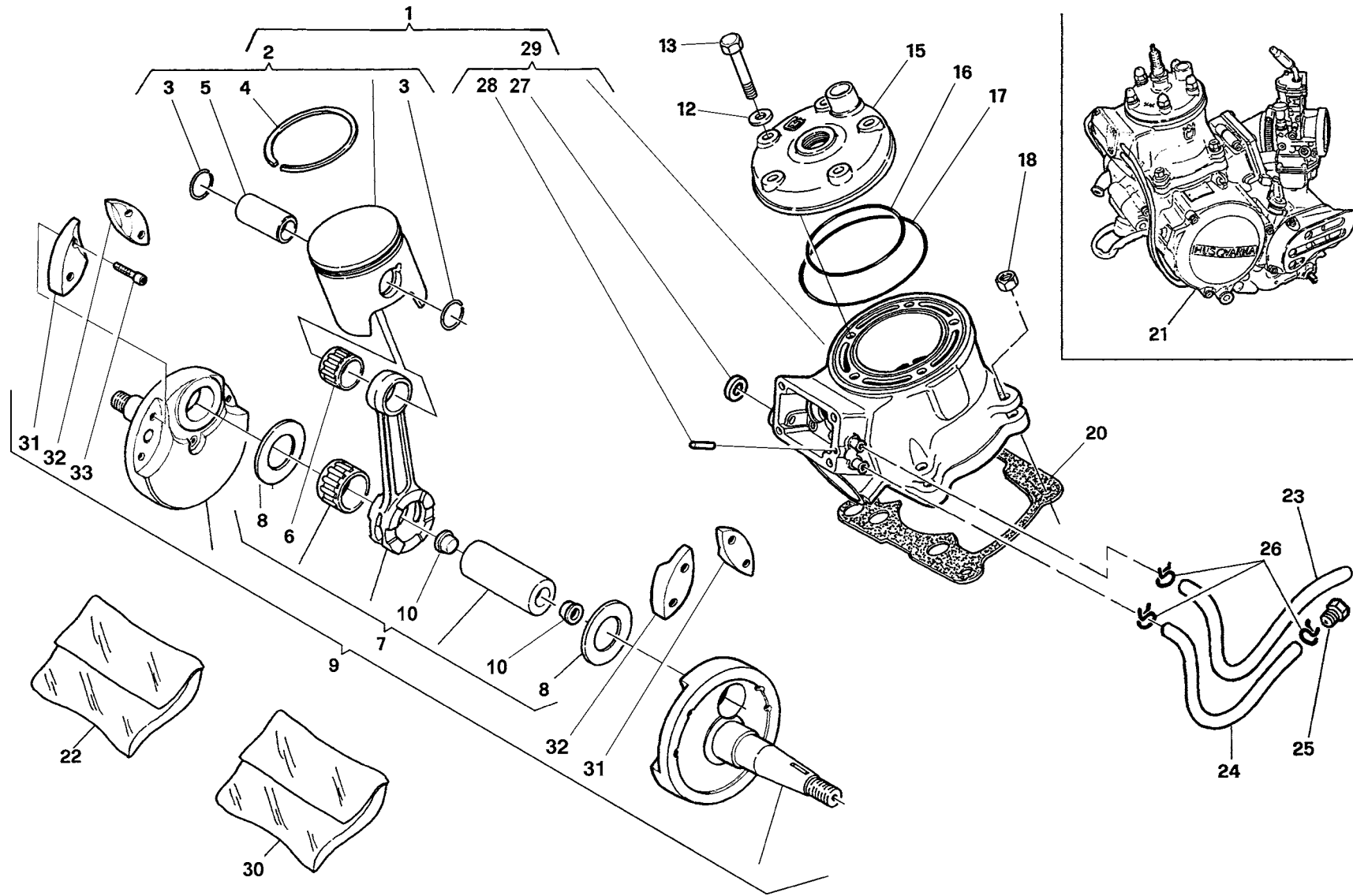

Note Notes Notes Marke Notas	Pos. No. N. Index Pos.	N. Cod. Code No. Nr. Code Code Nr N. Cod.	Q.tà Q.ty Q.te M.ge C.ad	DENOMINAZIONE	NAME	DESIGNATION	BESCHREIBUNG	DENOMINACION	Validità Validity Validité Gültig Validez
	1	8000 99817	1	Cilindro completo	Cylinder assy	Cylindre compl.	Zylinder Kpl	Cilindro compl.	
	2	8000 99749/1	1	Pistone completo (A-B ø 53,940 ÷ 53,950 mm)	Compl. piston (A-B ø 53,940 ÷ 53,950 mm)	Piston complet (A-B ø 53,940 ÷ 53,950 mm)	Kolben, kpl. (A-B ø 53,940 ÷ 53,950 mm)	Pistón completo (A-B ø 53,940 ÷ 53,950 mm)	
	2	8000 99749/2	1	Pistone completo (C-D ø 53,950 ÷ 53,960 mm)	Compl. piston (C-D ø 53,950 ÷ 53,960 mm)	Piston complet (C-D ø 53,950 ÷ 53,960 mm)	Kolben, kpl. (C-D ø 53,950 ÷ 53,960 mm)	Pistón completo (C-D ø 53,950 ÷ 53,960 mm)	
	2	8000 99749/3	1	Pistone completo (E-F ø 53,960 ÷ 53,970 mm)	Compl. piston (E-F ø 53,960 ÷ 53,970 mm)	Piston complet (E-F ø 53,960 ÷ 53,970 mm)	Kolben, kpl. (E-F ø 53,960 ÷ 53,970 mm)	Pistón completo (E-F ø 53,960 ÷ 53,970 mm)	
	3	8000 10314	2	Anellino ritegno spinotto	Circlip	Bague d'arret	Federring	Anillo de retención	
	4	8000 A4506	1	Segmento	Circlip	Segment	Kolbenring	Segmento	
	5	8000 83066	1	Spinotto	Gudgeon	Axe	Bolzen	Perno	
	6	8000 83071	1	Cuscinetto a rullini (ø15xØ19x17,3 mm)	Needle bearing (ø15xØ19x17,3 mm)	Roulement à aiguilles (ø15xØ19x17,3 mm)	Nadelkafig (ø15xØ19x17,3 mm)	Cojinete (ø15xØ19x17,3 mm)	
	7	8000 88810	1	Biella motore compl.	Connecting rod compl.	Bielle compl.	Pleuelstange kpl.	Biela motor completa	
	8	8000 50629	2	Rosetta	Washer	Rondelle	Scheibe	Arandela	
	9	8000 92779	1	Compl. albero motore	Crankshaft assy	Vilebrequin compl.	Kurbewelle kpl.	Cigüeñal compl.	
	10	8000 57196	1	Tappo	Plug	Bouchon	Verschluss	Tapòn	
	12	8B00 64988	5	Rosetta	Washer	Rondelle	Scheibe	Arandela	
	13	8K00 69056	5	Vite (M8 x 35 mm)	Screw (M8 x 35 mm)	Vis (M8 x 35 mm)	Schraube (M8 x 35 mm)	Tornillo (M8 x 35 mm)	
	15	8000 83070	1	Testa cilindro	Cylinder head	Culasse cylindre	Zylinderkopf	Culada cilindro	
	16	8000 39630	1	Anello OR interno	O Ring	Bague OR	O Ring	Anillo OR	
	17	8000 70635	1	Anello OR esterno	O Ring	Bague OR	O Ring	Anillo OR	
	18	80B0 43928	4	Dado frenato	Nut	Ecrou	Mutter	Tuerca	
	20	8000 83068	1	Guarnizione (0,3 mm)	Gasket (0,3 mm)	Garnitue (0,3 mm)	Dichtung (0,3 mm)	Junta (0,3 mm)	
	20	8A00 83068	1	Guarnizione (0,4 mm)	Gasket (0,4 mm)	Garnitue (0,4 mm)	Dichtung (0,4 mm)	Junta (0,4 mm)	
	20	8B00 83068	1	Guarnizione (0,5 mm)	Gasket (0,5 mm)	Garnitue (0,5 mm)	Dichtung (0,5 mm)	Junta (0,5 mm)	
	20	8D00 83068	1	Guarnizione (0,8 mm)	Gasket (0,8 mm)	Garnitue (0,8 mm)	Dichtung (0,8 mm)	Junta (0,8 mm)	
W	21	8000 A1686	1	Motore completo	Engine assy	Moteur compl.	Motor kpl.	Guepial compl.	
U	21	8000 A1717	1	Motore completo	Engine assy	Moteur compl.	Motor kpl.	Guepial compl.	
C	21	8000 A2803	1	Motore completo	Engine assy	Moteur compl.	Motor kpl.	Guepial compl.	
R	22	8000 94652	1	Gruppo guarnizioni motore	Engine gasket set	Groupe garniture moteur	Dichtunggruppe Motor	Grupo juntas	
	23	8000 83056	1	Tubo sfiato	Pipe	Tuyau	Rohr	Tubo	
	24	8A00 83056	1	Tubo sfiato	Pipe	Tuyau	Rohr	Tubo	
	25	8000 79560	1	Tappo	Plug	Bouchon	Verschluss	Tapòn	



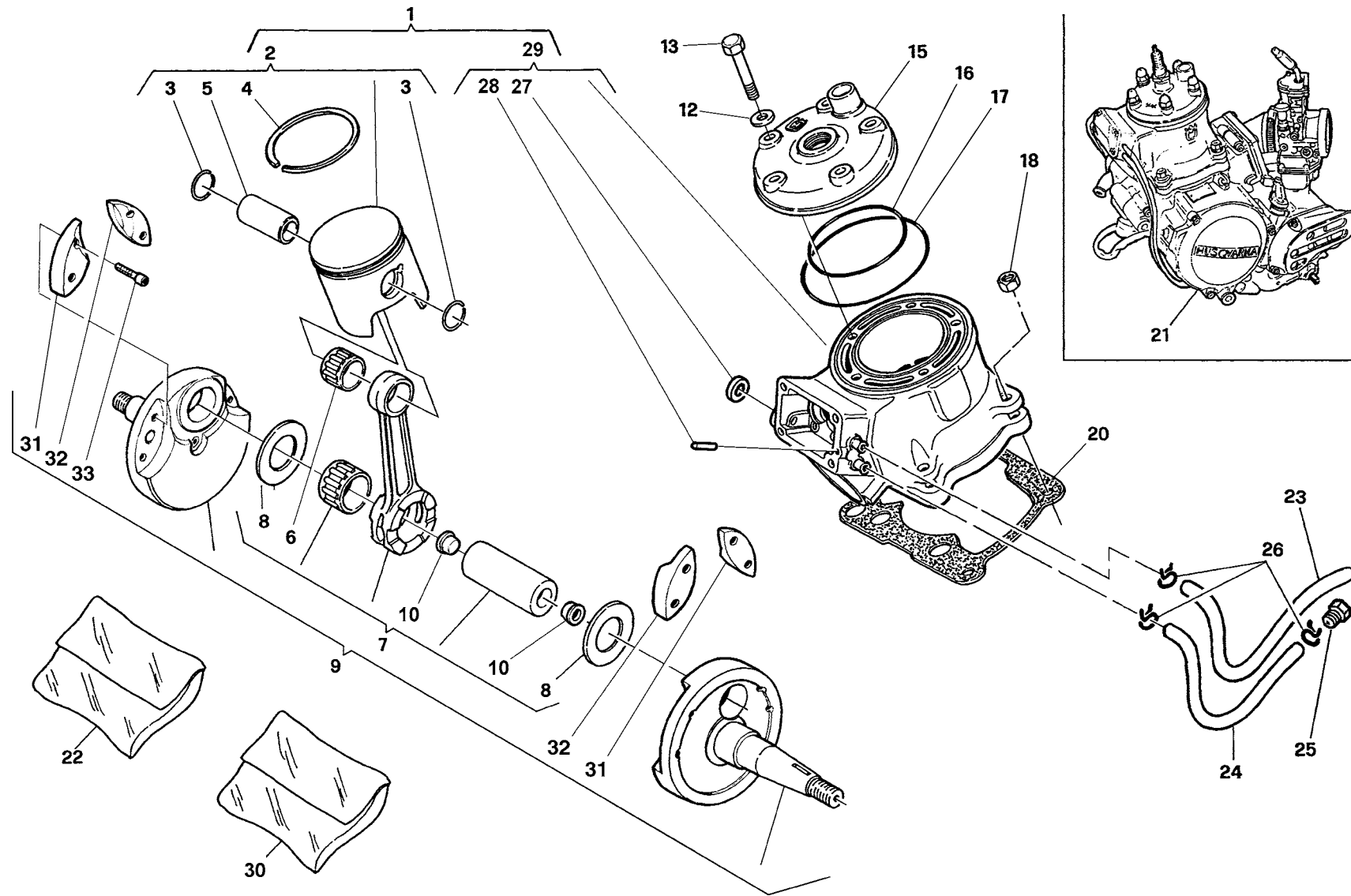

Note Notes Notes Marke Notas	Pos. No. N. Index Pos.	N. Cod. Code No. Nr. Code Code Nr N. Cod.	Q.tà Q.ty Q.te M.ge C.ad	DENOMINAZIONE	NAME	DESIGNATION	BESHREIBUNG	DENOMINACION	Validità Validity Validité Gültig Validez
	26	8A00 40433	3	Fascetta	Clamp	Collier	Schelle	Banda	
	27	8000 64296	1	Anello di tenuta Ø16 ø8 Sp.5	Seal ring Ø16 ø8 Th.5	Bague de retenue Ø16 ø8 ép. 5	Dichtring Ø16 ø8 S.5	Anillo de retención Ø16 ø8 esp.5	
	28	8000 47773	1	Rullino	Roller	Aiguille	Rolle	Rodillo	
	29	8000 83063	1	Cilindro	Cylinder	Cylindre	Zylinder	Cilindro	
R	30	8000 94852	1	Gruppo anelli di tenuta motore	Engine seal ring set	Groupe bague moteur	Dichtringgruppe Motor	Grupo anillos	
	31	8000 92785	2	Inserto	Insert	Insert	Platte	Inserto	
	32	8000 92786	2	Inserto	Insert	Insert	Platte	Inserto	
	33	60N1 02486	8	Vite	Screw	Vis	Schraube	Tornillo	

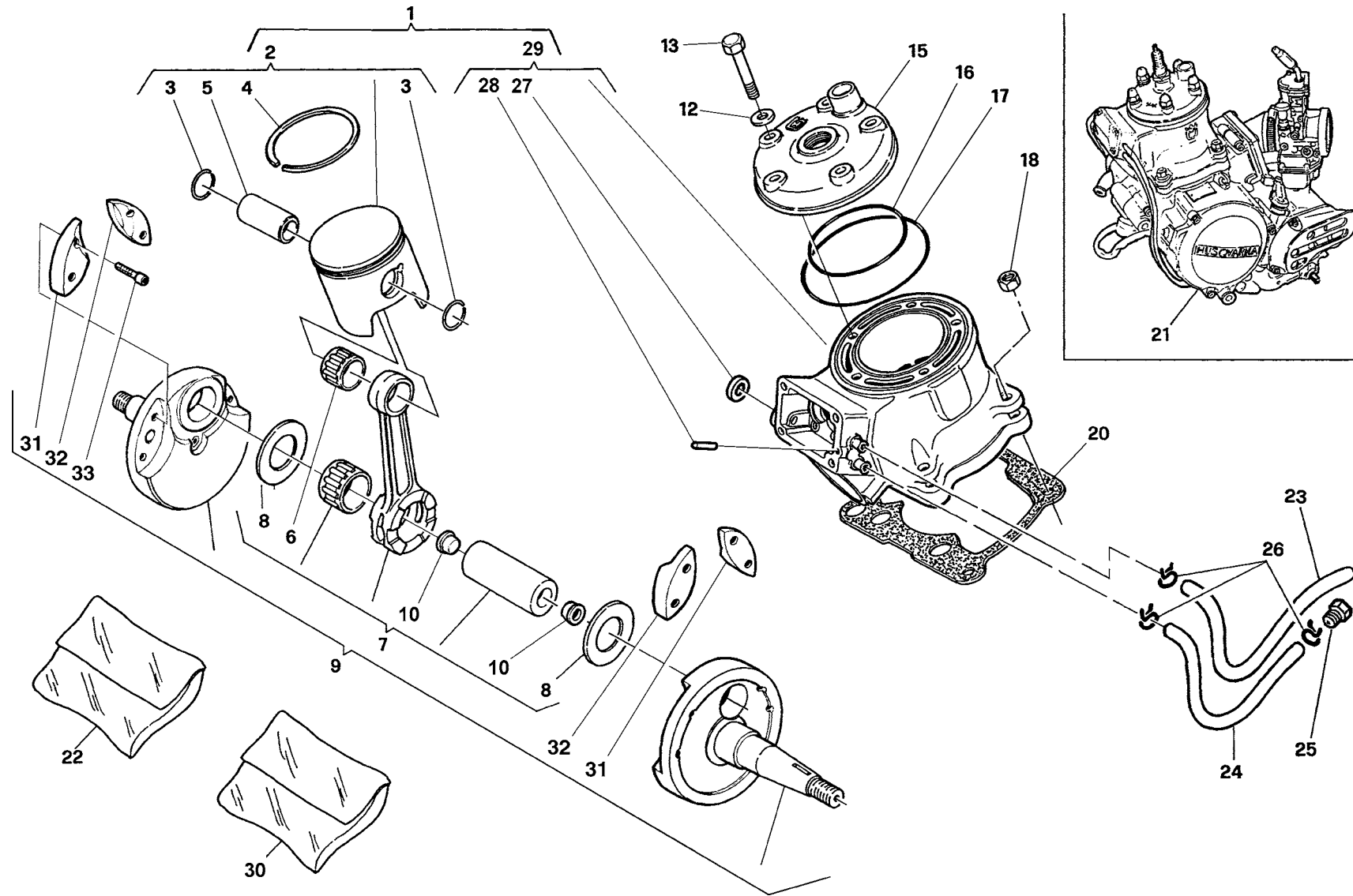

La sottoriportata tabella elenca i possibili accoppiamenti che consentono di ottenere il corretto gioco radiale di 0,002÷0,010 mm

The table hereunder shows the possible coupling which allow to obtain a radial clearance of 0.002÷0.010 mm

Le tableau ci-dessous indique tous les couplages possibles permettant d'obtenir le jeu radial exact de 0,002÷0,010 mm

Die folgende Tabelle gibt die möglichen Verbindungen an für das genaue Radialspiel von 0,002÷0,010 mm

La tabla que se da a continuación lista los acoplamientos posibles que permiten obtener el juego radial correcto de 0,002÷0,010 mm

C: colore di selezione biella

C: rod selection colour

C: couleur de sélection bielle

C: Wahlfarbe der Pleuelstange

C: color de selección biela

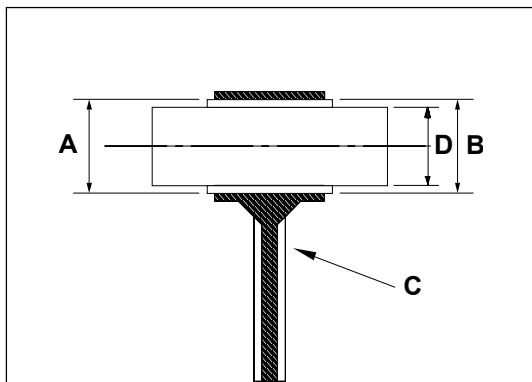

Colore di selezione foro «A» piede di biella (mm) Hole selection colour «A» connecting rod small end (mm) Couleur de sélection trou «A» pied de bielle (mm) Wahlfarbe der Bohrung «A» Pleuelstangenkopf (mm) Color de selección «A» pie de biela (mm)	Selezione gabbia a rullini «B» Cage selection «B» Sélection cage à rouleaux «B» Wahlnadelkäfig «B» Selección jaula de agujas «B»	Colore di selezione diametro «D» spinotto (mm) Diameter selection colour «D» Gudgeon (mm) Couleur de sélection diamètre «D» axe (mm) Wahlfarbe der Durchmesser «D» Bolzen (mm) Color de selección diámetro «D» perno (mm)
Rosso - Red - Rouge - Rot - Rojo 19,002 ÷ 19,004	0 ÷ - 2	Nero - Black - Noir - Schwarz - Negro 15,000 ÷ 14,998
Bianco - White - Blanc - Weiss - Blanco 18,998 ÷ 19,000	- 1 ÷ - 3	Bianco - White - Blanc - Weiss - Blanco 14,998 ÷ 14,996
Nero - Black - Noir - Schwarz - Negro 19,000 ÷ 19,002	0 ÷ - 2	Bianco - White - Blanc - Weiss - Blanco 14,998 ÷ 14,996
Nero - Black - Noir - Schwarz - Negro 19,000 ÷ 19,002	- 1 ÷ - 3	Nero - Black - Noir - Schwarz - Negro 15,000 ÷ 14,998

Qualora, in sede di revisione del motore, si dovesse riscontrare un gioco radiale superiore al limite ammesso di 0,015 mm e non fosse più visibile il contrassegno del colore sullo stelo della biella, rilevare il diametro «A» del piede di biella e, in base a questo, montare la gabbietta appropriata.

When overhauling, should a radial clearance greater than the consented limit of 0.015 mm be noticed and the colour mark under the connecting rod small end is no more visible, collect the connecting rod small end «A» diameter and assemble the right cage according to it.

Si en révisonnant le moteur on trouve un jeu radial supérieur à la limite admise de 0,015 mm et le marque de la couleur n'est plus visible sur la tige de bielle, enregistrer le diamètre «A» du pied de bielle et assembler la cage exacte selon ce diamètre.

Falls bei Motorprüfung das Radialspiel über das zugelassene Mass von 0,015 mm sein sollte und das Farbkennzeichen an der Pleuelstange nicht mehr sichtbar ist, wird der «A»-Durchmesser des Pleuelstangenkopfes gemessen und aufgrund dessen der geeignete Käfig montiert..

En el caso que, cuando inspeccione el motor, encuentre un juego radial superior al límite admitido de 0,015 mm y no resultara más visible la señalización del color en el vástago de la biela, registre el diámetro «A» del piede biela y, sobre la base de este dato, monte la jaula adecuada.

NOTA: Nel richiedere la gabbia a rullini, specificare la selezione.

NOTE: When requesting the cage, specify the selection.

NOTA: En demandant la cage à rouleaux, spécifier la sélection.

BEMERKUNG: Bei Anfrage den genauen Wahlnadelkäfig angeben.

NOTA: cuando pida la jaula de agujas, especifique la selección.

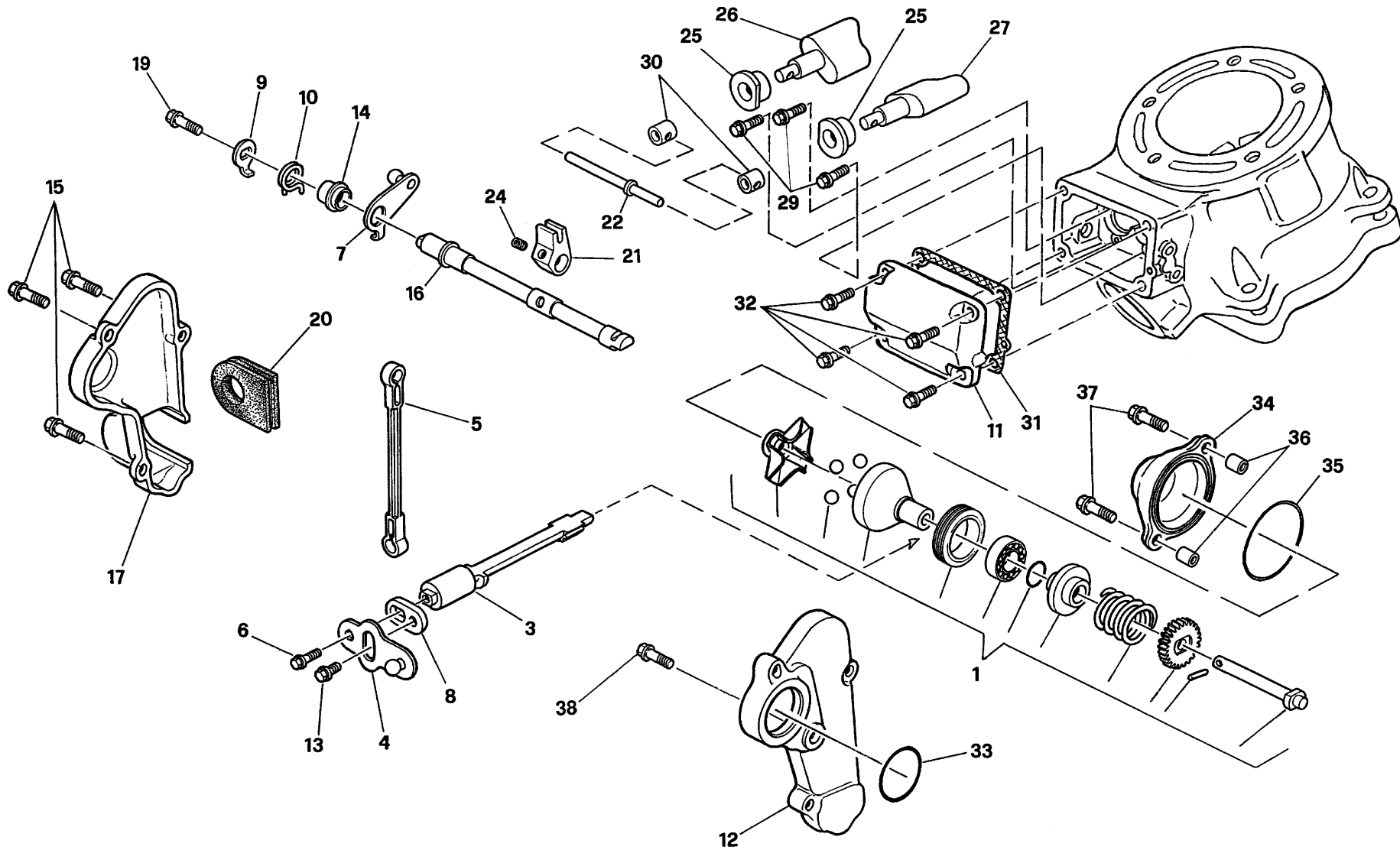



Note Notes Notes Marke Notas	Pos. No. N. Index Pos.	N. Cod. Code No. Nr. Code Code Nr N. Cod.	Q.tà Q.ty Q.te M.ge C.ad.	DENOMINAZIONE	NAME	DESIGNATION	BESHREIBUNG	DENOMINACION	Validità Validity Validité Gültig Validez
	1	8000 99753	1	Assieme regolatore centrifugo	Regulator assy	Reglage	Regler	Regulador	
	3	8000 83107	1	Alberino	Shaft	Arbre	Welle	Eje	
	4	8B00 57022	1	Assieme leva registro rinvio	Lever	Levier	Hebel	Palanca	
	5	8000 83115	1	Astina	Brake	Tige	Stange	Varilla	
	6	8000 67997	1	Vite	Screw	Vis	Schraube	Tornillo	
	7	8000 83111	1	Assieme leva	Lever	Levier	Hebel	Palanca	
	8	8A00 57024	1	Leva rinvio	Lever	Levier	Hbel	Palanca	
	9	8000 83110	1	Leva	Lever	Levier	Hbel	Palanca	
	10	8000 83109	1	Molla	Spring	Ressort	Feder	Resorte	
	11	8000 83090	1	Coperchio	Cover	Couvercle	Deckel	Tapa	
	12	8000 83094	1	Basetta	Side	Base	Platte	Placa	
	13	8F00 67997	1	Vite	Screw	Vis	Schraube	Tornillo	
	14	8000 83114	1	Mozzo	Hub	Moyeau	Radnabe	Cubo	
	15	8A00 67997	3	Vite	Screw	Vis	Schraube	Tornillo	
	16	8000 83116	1	Albero comando valvole	Valve shaft	Arbre de comande soupape	Ventilwelle	Eje mando valvula	
	17	8000 83093	1	Coperchio	Cover	Couvercle	Deckel	Tapa	
	19	8000 67997	1	Vite	Screw	Vis	Schraube	Tornillo	
	20	8000 83092	1	Guarnizione	Gasket	Guarniture	Dichtung	Junta	
	21	8000 83119	1	Biscottino leva	Lever	Levier	Hbel	Palanca	
	22	8000 83113	1	Perno di trascinamento	Pin	Pivot	Bolzen	Perno	
	24	8000 83121	1	Grano	Dowel	Grain	Stift	Pasadòr	
	25	8000 83118	2	Bussola ritegno valvole	Valve retaining bush	Douille	Buchse	Manguito	
E	26	8000 83122	1	Valvola di scarico Dx	R.H. exhaust valve	Soupape d'echappement D.	Auslassventil R.	Valvula de escape der.	
F	26	8000 A3555	1	Valvola di scarico Dx	R.H. exhaust valve	Soupape d'echappement D.	Auslassventil R.	Valvula de escape der.	
E	27	8000 83123	1	Valvola di scarico Sx	L.H. exhaust valve	Soupape d'echappement G.	Auslassventil L.	Valvula de escape iz.	
F	27	8000 A3556	1	Valvola di scarico Sx	L.H. exhaust valve	Soupape d'echappement G.	Auslassventil L.	Valvula de escape iz.	
	29	8E00 67997	3	Vite	Screw	Vis	Schraube	Tornillo	
E	30	8000 99755	2	Fermo corsa	Retainer	Arret	Klammer	Abrazaderza	
F	30	8000 A3557	2	Fermo corsa	Retainer	Arret	Klammer	Abrazaderza	
	31	8000 83049	1	Guarnizione	Gasket	Guarniture	Dichtung	Junta	
	32	8A00 67997	4	Vite	Screw	Vis	Schraube	Tornillo	
	33	8000 19789	1	Anello "OR"	"O"ring	Bague OR	"O"Ring	Anillo OR	
	34	80B0 83076	1	Coperchio regolatore	Cover	Couvercle	Deckel	Tapa	

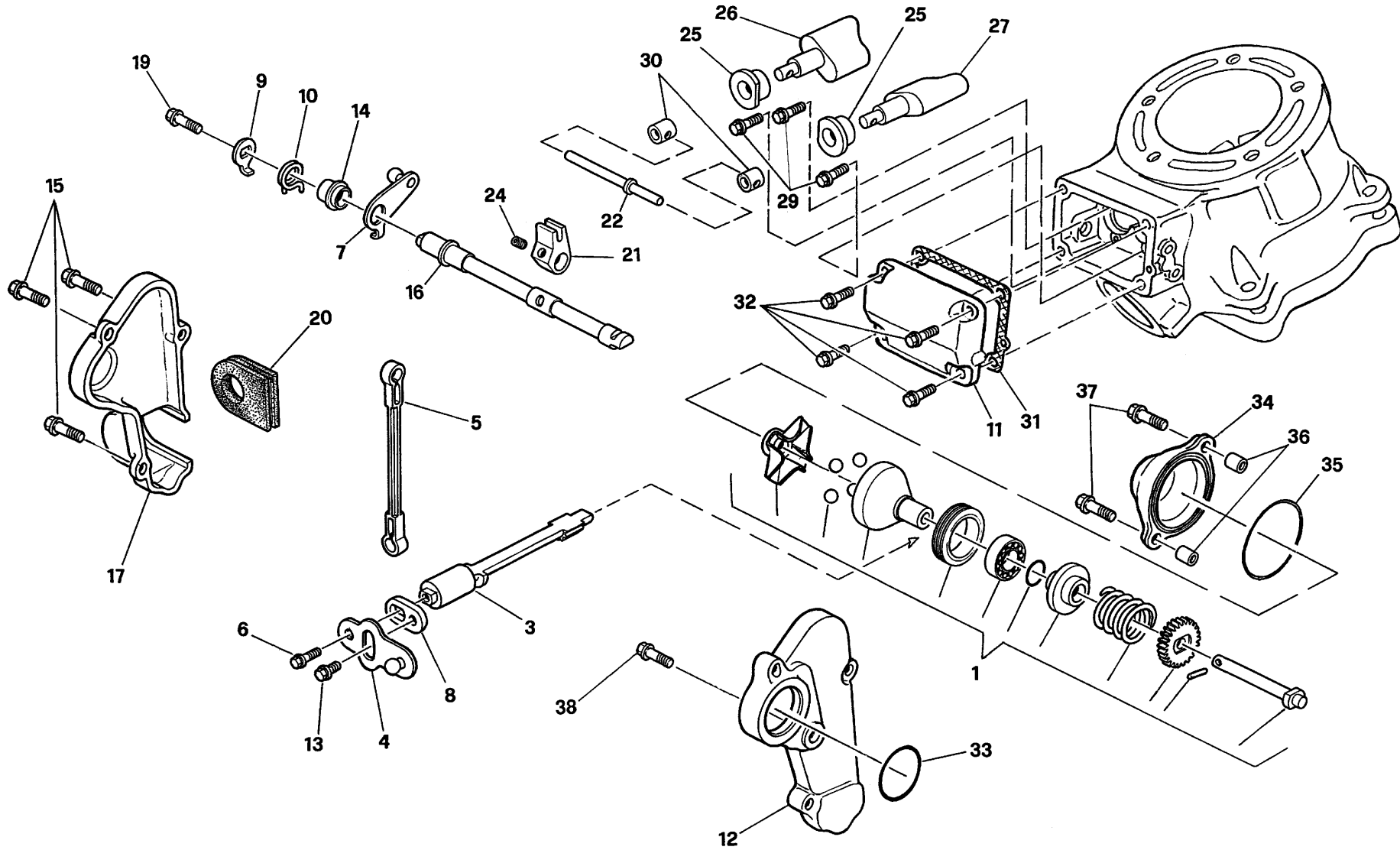

Note Notes Marke Notas	Pos. No. N. Index Pos.	N. Cod. Code No. Nr. Code Code Nr N. Cod.	Q.tà Q.ty Q.te M.ge C.ad	DENOMINAZIONE	NAME	DESIGNATION	BESHREIBUNG	DENOMINACION	Validità Validity Validité Gültig Validez
	35	8000 28553	1	Anello di tenuta	Seal ring	Bague de retenue	Dichtring	Anillo de retencion	
	36	1617 95501	2	Bussola	Bushing	Douille	Buchse	Manguito	
	37	8000 62729	2	Vite	Screw	Vis	Schraube	Tornillo	
	38	8000 67997	1	Vite	Screw	Vis	Schraube	Tornillo	
F				Accoppiare con particolare 8000 A3557 pos. 30	Supply unittedly to part. 8000 A3557 pos. 30	Fournir ensemble à part. 8000 A3557 pos. 30	Paaren mit Teile 8000 A3557 pos. 30	Equipar acoplado al part. 8000 A3557 pos. 30	

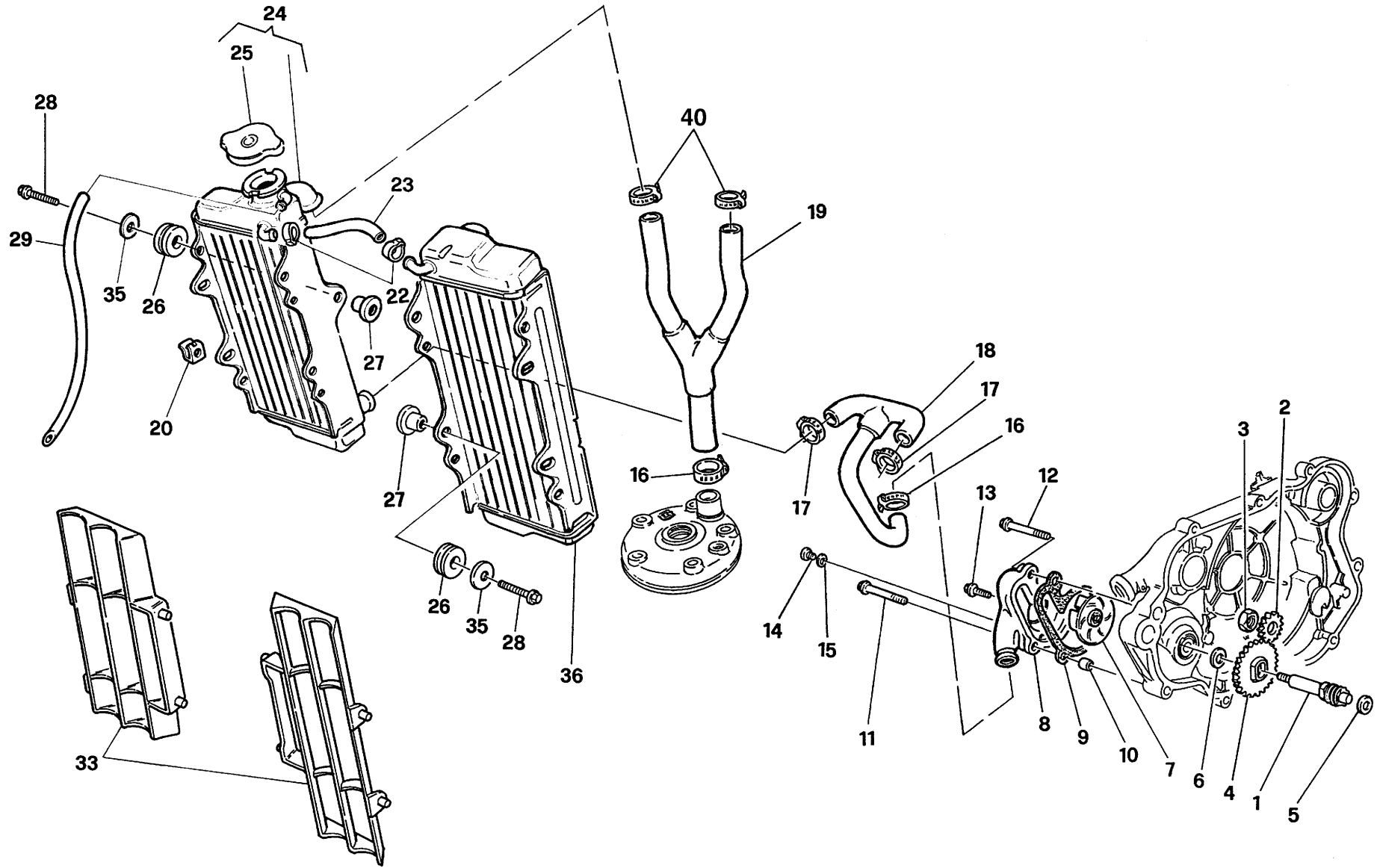

Note Notes Notes Marke Notas	Pos. No. N. Index Pos.	N. Cod. Code No. Nr. Code Code Nr N. Cod.	Q.tà Q.ty Q.te M.ge C.ad	DENOMINAZIONE	NAME	DESIGNATION	BESHREIBUNG	DENOMINACION	Validità Validity Validité Gültig Validez
	1	8000 79561	1	Alberino com. pompa acqua	Shaft	Arbre	Welle	Eje	
	2	8000 65923	1	Pignone	Pinion	Pignon	Ritzel	Engranaje	
	3	8A00 04883	1	Dado	Nut	Ecrou	Mutter	Tuerca	
	4	8000 65935	1	Ingranaggio pompa	Pinion	Pignon	Ritzel	Engranaje	
	5	8E00 34292	1	Rosetta	Washer	Rondelle	Scheibe	Arandela	
	6	8F00 28960	1	Rosetta	Washer	Rondelle	Scheibe	Arandela	
	7	8000 68277	1	Girante	Rotor	Couronne	Laufrad	Rotor	
	8	80B0 83024	1	Corpo pompa	Pump body	Corps pompe	Pumpenkoper	Corpo bomba	
	9	8000 65922	1	Guarnizione	Gasket	Garniture	Dichtung	Junta	
	10	1617 95501	2	Bussola	Bushing	Douille	Buchse	Manguito	
	11	8000 62731	1	Vite (M6 x 45 mm)	Screw (M6 x 45 mm)	Vis (M6 x 45 mm)	Schraube (M6 x 45 mm)	Tornillo (M6 x 45 mm)	
	12	8B00 67545	1	Vite (M6 x 55 mm)	Screw (M6 x 55 mm)	Vi s (M6 x 55 mm)	Schraube (M6 x 55 mm)	Tornillo (M6 x 55 mm)	
	13	8000 62728	1	Vite	Screw	Vis	Schraube	Tornillo	
	14	8S00 67545	1	Vite	Screw	Vis	Schraube	Tornillo	
	15	8000 03271	1	Rosetta	Washer	Rondelle	Scheibe	Arandela	
	16	8B00 99475	2	Fascetta	Clamp	Collier	Schelle	Banda	
	17	8A00 99475	2	Fascetta	Clamp	Collier	Schelle	Banda	
	18	8000 88894	1	Tubo radiatori- pompa	Pipe	Tuyau	Rohr	Tubo	
	19	8000 93181	1	Tubo testa-radiatori	Pipe	Tuyau	Rohr	Tubo	
	20	8000 60873	4	Dado a graffetta	Nut	Ecrou	Mutter	Tuerca	
	22	8000 56462	2	Fascetta	Clamp	Collier	Schelle	Banda	
	23	8C00 43716	1	Tubo raccordo radiatori	Pipe	Tuyau	Rohr	Tubo	
	24	8000 92216	1	Radiatore destro	Right radiator	Radiateur droit	Rechter Kühler .	Radiador derecho	
	25	8000 79077	1	Tappo radiatore	Plug	Bouchon	Verschluss	Tapón	
	26	8000 59803	6	Gommino	Rubber pad	Pièce caoutchouc	Gummistück	Junta de goma	
	27	8D00 59802	6	Bussola	Bushing	Douille	Buchse	Manguito	
	28	8000 62729	6	Vite	Screw	Vis	Schraube	Tornillo	
	29	8B00 43715	1	Tubo sfiato (L=660 mm)	Pipe (L=660 mm)	Tuyau (L=660 mm)	Rohr (L=660 mm)	Tubo (L=660 mm)	
	33	8000 A0872	2	Griglia	Grid	Grille	Rost	Parrilla	
	35	8000 59801	6	Rosetta	Washer	Rondelle	Scheibe	Arandela	
	36	8000 92215	1	Radiatore sinistro	Left radiator	Radiateur gauche	Linker Kühler	Radiador izquierdo	
	40	8A00 99475	2	Fascetta	Clamp	Collier	Schelle	Banda	



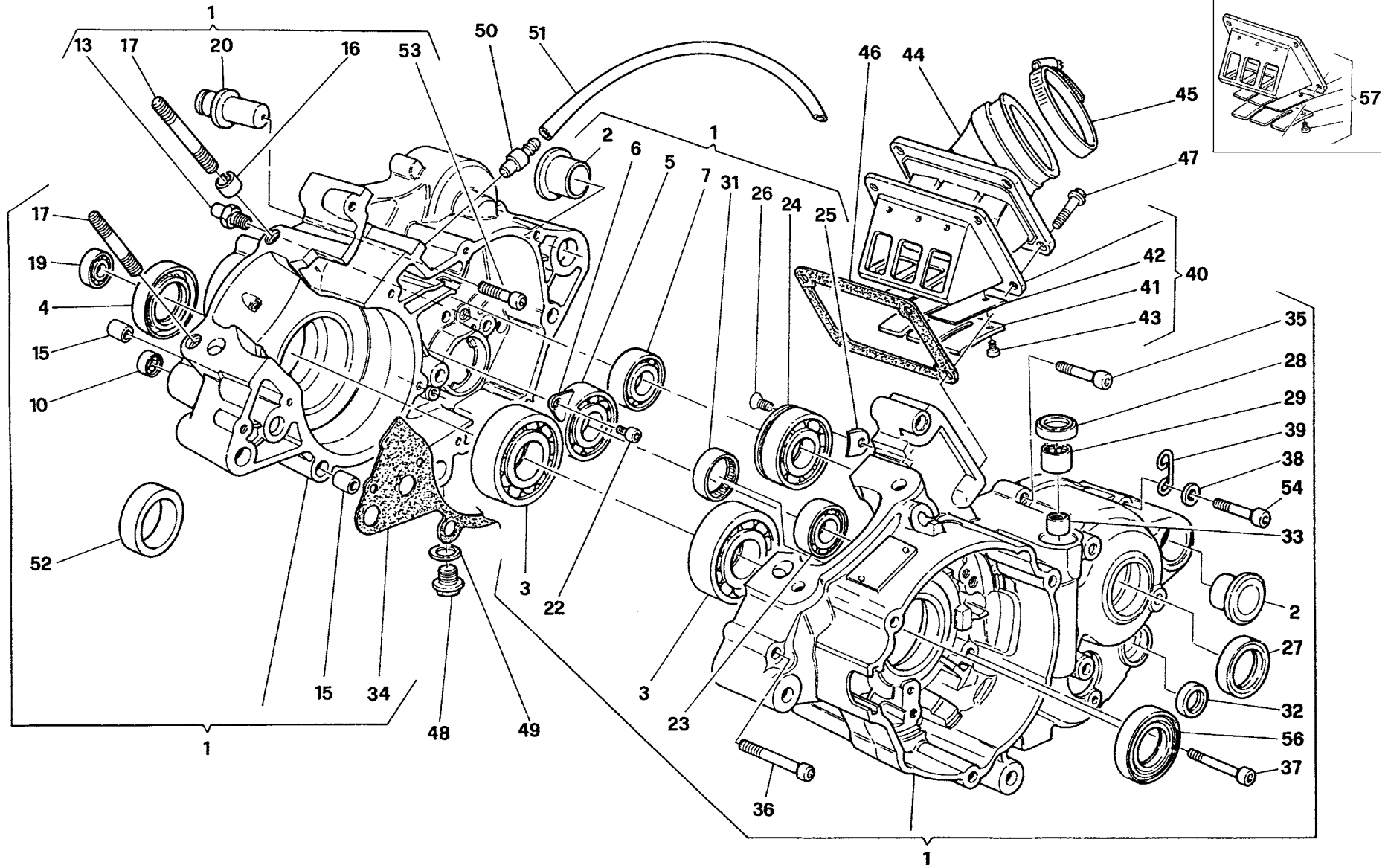

Note Notes Notes Marke Notas	Pos. No. N. Index Pos.	N. Cod. Code No. Nr. Code Code Nr N. Cod.	Q.tà Q.ty Q.te M.ge C.ad	DENOMINAZIONE	NAME	DESIGNATION	BESHREIBUNG	DENOMINACION	Validità Validity Validité Gültig Validez
	1	8000 88815	1	Carter accoppiati compl.	Crankcase assy	Carters assemblé compl.	Kürbelgehäuse kpl.	Carter motor compl.	
	2	8A00 71154	2	Bussola	Bushing	Douille	Büshse	Manguito	
	3	8000 88828	2	Cuscinetto Ø56 ø22 Sp.16	Ball bearing Ø56 ø22 Th.16	Roulement Ø56 ø22 ép.16	Lager Ø56 ø22 S.16	Cojienete Ø56 ø22 esp.16	
	4	8000 59977	1	Anello di tenuta (ø32xØ40x5 mm)	Seal ring (ø32xØ40x7,5 mm)	Bague d'étanchéité (ø32xØ40x5 mm)	Dichtungsring (ø32xØ40x5 mm)	Anillo de retención (ø32xØ40x5 mm)	
	5	8000 43382	1	Cuscinetto (ø17xØ47x14 mm)	Bearing (ø17xØ47x14 mm)	Roulement (ø17xØ47x14 mm)	Lager (ø17xØ47x14 mm)	Cojienete (ø17xØ47x14 mm)	
	6	8000 53324	1	Piastrina	Plate	Plaquette	Plättchen	Placa	
	7	8000 21939	1	Cuscinetto (ø15xØ35x11 mm)	Bearing (ø15xØ35x11 mm)	Roulement (ø15xØ35x11 mm)	Lager (ø15xØ35x11 mm)	Cojienete (ø15xØ35x11 mm)	
	10	8000 47678	1	Cuscinetto a rullini (ø8xØ12x8mm)	Needle bearing (ø8xØ12x8 mm)	Roulement à aiguilles	Nadelkafig (ø8xØ12x8 mm)	Cojienete (ø8xØ12x8 mm)	
	13	8A00 66953	1	Perno	Pin	Pivot	Bolzen	Perno	
	15	8000 07719	1	Bussola	Bushing	Douille	Büshse	Manguito	
	16	8000 99767	1	Spina elastica	PIN	Goupille	Stift	Clavija	
	17	8000 74836	4	Prigioniero (M8 x 51 mm)	Stud bolt (M8 x 51 mm)	Prisonnier (M8 x 51 mm)	Stiftschraube (M8 x 51 mm)	Prisionero (M8 x 51 mm)	
	19	8000 06597	1	Cuscinetto (ø8xØ22x7 mm)	Bearing (ø8xØ22x7 mm)	Roulement (ø8xØ22x7 mm)	Lager (ø8xØ22x7 mm)	Cojienete (ø8xØ22x7 mm)	
	20	8000 77841	1	Perno	Pin	Pivot	Bolzen	Perno	
	22	8000 67997	1	Vite	Screw	Vis	Schraube	Tornillo	
	23	8000 21939	1	Cuscinetto (ø15xØ35x11 mm)	Bearing (ø15xØ35x11 mm)	Roulement (ø15xØ35x11 mm)	Lager (ø15xØ35x11 mm)	Cojienete (ø15xØ35x11 mm)	
	24	8000 51745	1	Cuscinetto (ø20xØ52x15 mm)	Bearing (ø20xØ52x15 mm)	Roulement (ø20xØ52x15 mm)	Lager (ø20xØ52x15 mm)	Cojienete (ø20xØ52x15 mm)	
	25	8000 51746	1	Piastrina	Plate	Plaquette	Plättchen	Placa	
	26	8000 42643	1	Vite	Screw	Vis	Schraube	Tornillo	
	27	8000 36357	1	Anello di tenuta (ø26xØ35x7 mm)	Seal ring (ø26xØ35x7 mm)	Bague d'étanchéité (ø26xØ35x7 mm)	Dichtungsring (ø26xØ35x7 mm)	Anillo de retención (ø26xØ35x7 mm)	
	28	8000 48856	1	Anello (ø13xØ20x4 mm)	Seal ring (ø13xØ20x4 mm)	Bague d'étanchéité (ø13xØ20x4 mm)	Dichtungsring (ø13xØ20x4 mm)	Anillo de retención (ø13xØ20x4 mm)	
	29	8000 49016	1	Boccola (ø13xØ19x12 mm)	Bushing (ø13xØ19x12 mm)	Douille (ø13xØ19x12 mm)	Büchse (ø13xØ19x12 mm)	Manguito (ø13xØ19x12 mm)	
	31	8000 62200	1	Cuscinetto a rullini (ø24xØ30x7,5 mm)	Needle bearing (ø24xØ30x7,5 mm)	Roulement à aiguilles (ø24xØ30x7,5 mm)	Nadelkafig (ø24xØ30x7,5 mm)	Cojienete (ø24xØ30x7,5 mm)	
	32	8000 34451	1	Anello di tenuta (ø12xØ19x5 mm)	Seal ring (ø12xØ19x5 mm)	Bague d'étanchéité (ø12xØ19x5 mm)	Dichtungsring (ø12xØ19x5 mm)	Anillo de retención (ø12xØ19x5 mm)	
	33	8000 47678	1	Cuscinetto a rullini (ø8xØ12x8 mm)	Needle bearing (ø8xØ12x8 mm)	Roulement à aiguilles (ø8xØ12x8 mm)	Nadelkafig (ø8xØ12x8 mm)	Cojienete (ø8xØ12x8 mm)	
	34	8000 72889	1	Guarnizione	Gasket	Garnitue	Dichtung	Junta	

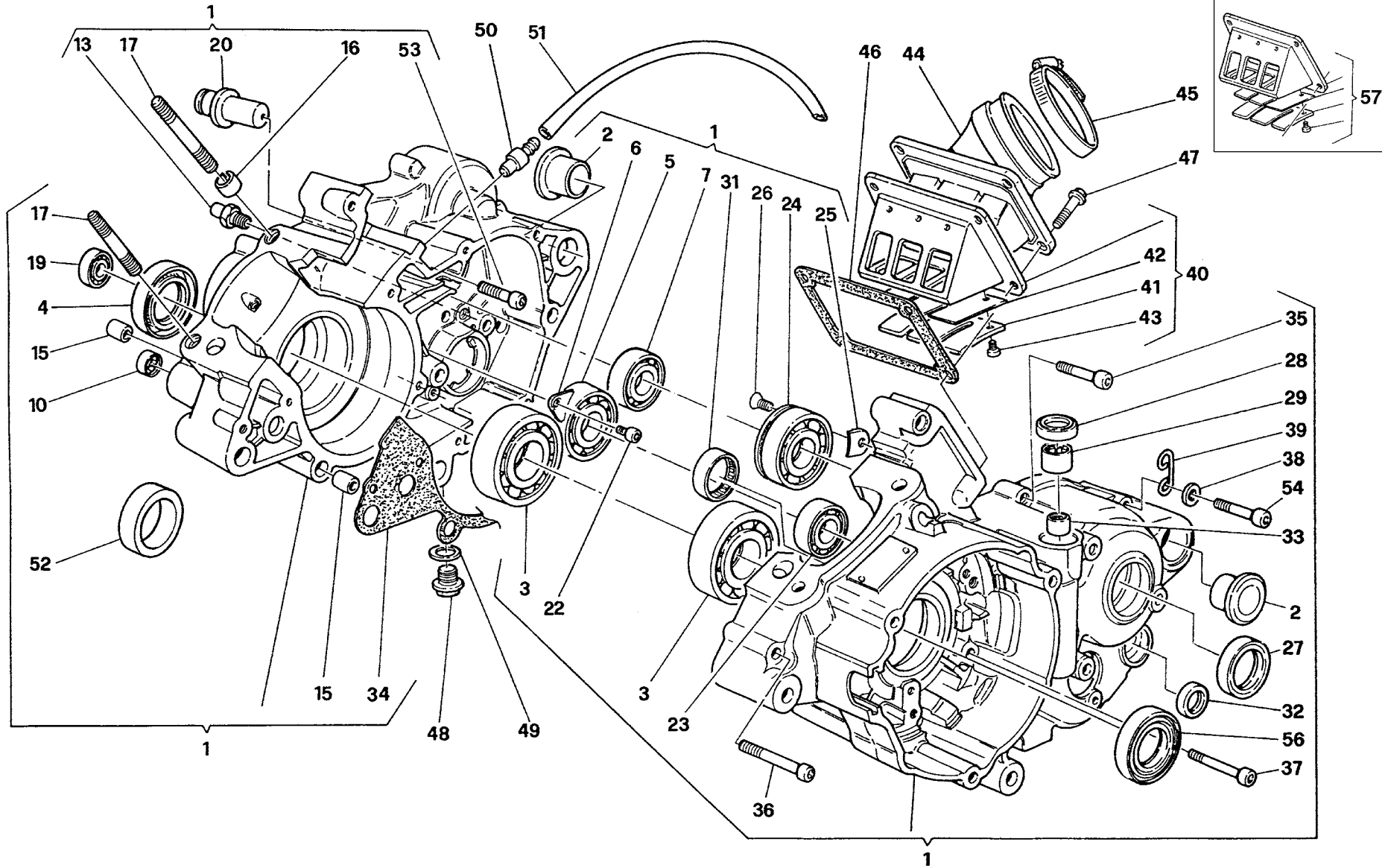

Note Notes Notas	Pos. No. N. Index Pos.	N. Cod. Code No. Nr. Code Code Nr N. Cod.	Q.tà Q.ty Q.te M.ge C.ad	DENOMINAZIONE	NAME	DESIGNATION	BESHREIBUNG	DENOMINACION	Validità Validity Validité Gültig Validez
	35	60N1 02512	5	Vite (M6x35 mm)	Screw (M6x35 mm)	Vis (M6x35 mm)	Schraube (M6x35 mm)	Tornillo (M6x35 mm)	
	36	60N1 02515	2	Vite (M6x50 mm)	Screw (M6x50 mm)	Vis (M6x50 mm)	Schraube (M6x50 mm)	Tornillo (M6x50 mm)	
	37	60N1 02514	3	Vite (M6x45 mm)	Screw (M6x45 mm)	Vis (M6x45 mm)	Schraube (M6x45 mm)	Tornillo (M6x45 mm)	
	38	62N1 15519	1	Rosetta	Washer	Rondelle	Scheibe	Arandela	
	39	8000 86951	1	Passatubo	Cable guide	Guidécâble	Kabelführung	Guja cable	
W	40	8000 76074	1	Valvola d'aspirazione compl.	Inlet valve	Soupape admission	Einlass-Ventil	Valvula aspiracion	
W	41	8000 76075	2	Piastrina fermo lamella	Plate	Plaquette	Plättchen	Placa	
W	42	8000 76076	2	Lamella	Plate	Plaquette	Plättchen	Placa	
W	43	8000 61102	6	Vite	Screw	Vis	Schraube	Tornillo	
W	44	8000 99756	1	Raccordo carburatore	Union	Raccord	Anschluss	Empalme	
U	44	8000 A0801	1	Raccordo carburatore	Union	Raccord	Anschluss	Empalme	
C	44	8000 A2804	1	Raccordo carburatore	Union	Raccord	Anschluss	Empalme	
WC	45	8G00 99475	1	Fascetta	Clamp	Collier	Schelle	Bandda	
U	45	8E00 99475	1	Fascetta	Clamp	Collier	Schelle	Bandda	
	46	8000 83043	1	Guarnizione	Gasket	Garnitue	Dichtung	Junta	
WU	47	8000 98213	4	Vite	Screw	Vis	Schraube	Tornillo	
C	47	8000 62728	4	Vite	Screw	Vis	Schraube	Tornillo	
	48	8000 75415	1	Tappo scarico olio	Oil drain plug	Bouchon vidange huile	Stöpsel f. ölablass	Tapón purga aceite	
	49	62N0 15678	1	Rosetta di tenuta	Washer	Rondelle	Scheibe	Arandela	
	50	8000 76262	1	Raccordo sfiato	Union	Raccord	Anschluss	Empalme	
	51	8000 41750	1	Tubetto	Pipe	Tuyau	Rohr	Tube	
	52	8000 74082	1	Tappo	Plug	Bouchon	Verschluss	Tapon	
	53	60N1 07335	1	Vite	Screw	Vis	Schraube	Tornillo	
	54	60N1 02518	2	Vite (M6x65 mm)	Screw (M6x65 mm)	Vis (M6x65 mm)	Schraube (M6x65mm)	Tornillo M6x65mm)	
	56	8000 92896	1	Anello di tenuta (ø20xø40x7 mm)	Seal ring (ø20xø40x7 mm)	Bague d'étanchéité (ø20xø40x7 mm)	Dichtungsring (ø20xø40x7 mm)	Anillo de retención (ø20xø40x7 mm)	
UC	57	8000 A0804	1	Valvola d'asp. compl.	Inlet valve	Soupape admission	Einlass-Ventil	Valvula aspiracion	

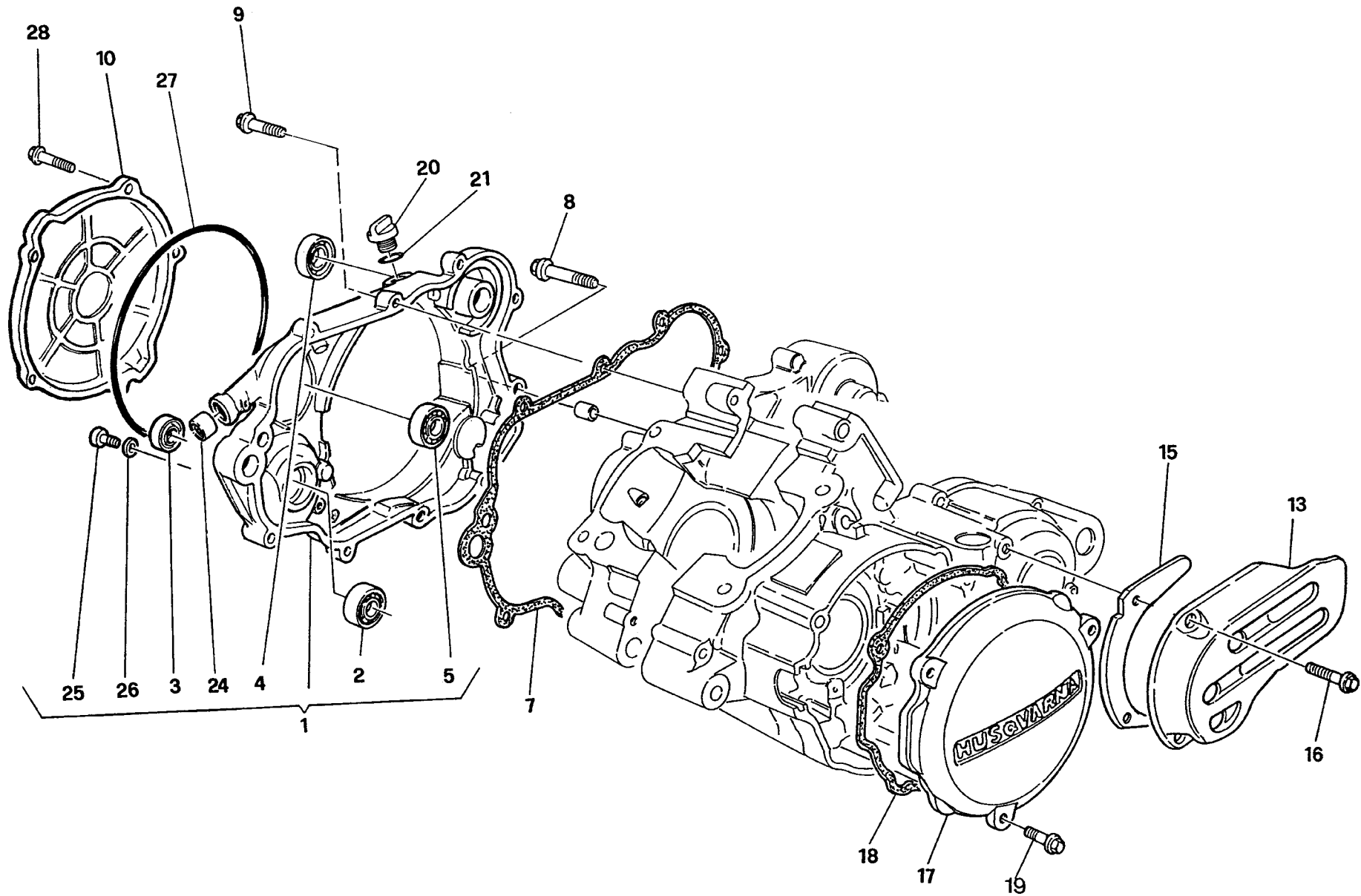

Note Notes Notas	Pos. No. N. Index Pos.	N. Cod. Code No. Nr. Code Code Nr N. Cod.	Q.tà Q.ty Q.te M.ge C.ad	DENOMINAZIONE	NAME	DESIGNATION	BESCHREIBUNG	DENOMINACION	Validità Validity Validité Gültig Validez
	1	8000 83073	1	Coperchio carter DX	R. H. crankcase cover	Couvercle carter D.	Deckel R. carter	Juego tapa carter lz.	
	2	8000 28959	2	Cuscinetto (ø10xØ26x8 mm)	Bearing (ø10xØ26x8 mm)	Roulement (ø10xØ26x8 mm)	Llager (ø10xØ26x8 mm)	Cojinete (ø10xØ26x8 mm)	
	3	8000 68278	1	Anello (ø8,6xØ18x8mm)	Ring (ø8,6xØ18x8 mm)	Bague (ø8,6xØ18x8 mm)	Ring (ø8,6xØ18x8 mm)	Ring (ø8,6xØ18x8 mm)	
	4	8000 36653	1	Anello (ø16xØ25x4 mm)	Ring (ø16xØ25x4 mm)	Bague (ø16xØ25x4 mm)	Ring (ø16xØ25x4 mm)	Ring (ø16xØ25x4 mm)	
	5	8000 06597	1	Cuscinetto (ø8xØ22x7 mm)	Bearing (ø8xØ22x7 mm)	Roulement (ø8xØ22x7 mm)	Llager (ø8xØ22x7 mm)	Cojinete (ø8xØ22x7 mm)	
	7	8000 66968	1	Guarnizione	Gasket	Garnitue	Dichtung	Junta	
	8	8A00 67545	2	Vite (M6x35 mm)	Screw (M6x35 mm)	Vis (M6x35 mm)	Schraube (M6x35 mm)	Tornillo (M6x35 mm)	
	9	8000 62729	6	Vite (M6x25 mm)	Screw (M6x25 mm)	Vis (M6x25 mm)	Schraube (M6x25 mm)	Tornillo (M6x25 mm)	
	10	80B0 83075	1	Coperchio frizione	Cover	Couvercle	Deckel	Tapa	
	13	8000 66973	1	Coperchio pignone	Cover	Couvercle	Deckel	Tapa accion. embrague	
	15	8000 74758	1	Piastrina	Plate	Plaque	Platte	Placa	
	16	8000 62727	2	Vite	Screw	Vis	Schraube	Tornillo	
	17	8AC0 66947	1	Coperchio volano	Cover	Couvercle	Deckel	Tapa accion. embrague	
	18	8000 66972	1	Guarnizione	Gasket	Garnitue	Dichtung	Junta	
	19	8000 62728	3	Vite	Screw	Vis	Schraube	Tornillo	
	20	8000 36786	1	Tappo per carico olio	Plug	Bouchon	Verschluss	Tapón intruduecion aceite	
	21	8000 27960	1	Anello OR	O Ring	Bague OR	Ring OR	Anillo OR	
	24	8000 48856	1	Anello (ø13xØ20x4 mm)	Ring (ø13xØ20x4 mm)	Bague (ø13xØ20x4 mm)	Ring (ø13xØ20x4 mm)	Ring (ø13xØ20x4 mm)	
	25	8S00 67545	1	Vite	Screw	Vis	Schraube	Tornillo	
	26	8000 03271	1	Guarnizione	Gasket	Garnitue	Dichtung	Junta	
	27	8000 39694	1	Anello OR	O Ring	Bague OR	Ring OR	Anillo OR	
	28	8000 62729	5	Vite (M6x25 mm)	Screw (M6x25 mm)	Vis (M6x25 mm)	Schraube (M6x25 mm)	Tornillo (M6x25 mm)	



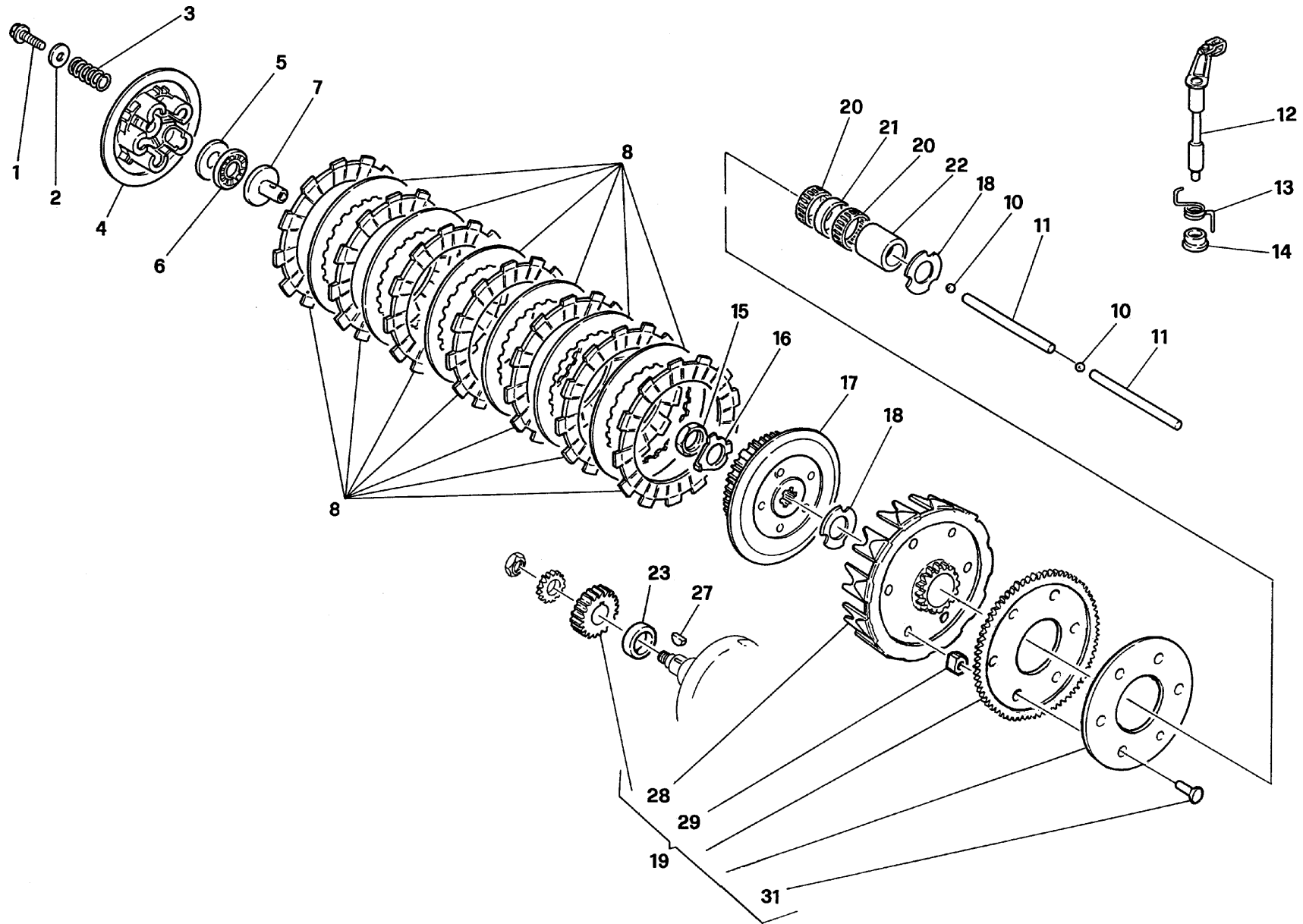

Note Notes Notas	Pos. No. N. Index Pos.	N. Cod. Code No. Nr. Code Code Nr N. Cod.	Q.tà Q.ty Q.te M.ge C.ad	DENOMINAZIONE	NAME	DESIGNATION	BESHREIBUNG	DENOMINACION	Validità Validity Validité Gültig Validez
	1	8000 62728	5	Vite	Screw	Vis	Schraube	Tornillo	
	2	8000 48814	5	Rosetta	Washer	Rondelle	Scheibe	Arandela	
	3	8000 83085	5	Molla	Spring	Ressort	Feder	Resorte	
	4	8000 70467	1	Spingidisco	Pressure plate	Pousse disque	Scheibendrucker	Empuia disco	
	5	8000 70551	1	Ralla	Washer	Rondelle	Scheibe	Arandela	
	6	8000 70550	1	Cuscinetto a rullini	Needle bearing	Roulement à aiguilles	Nadelkäfig	Cojinete	
	7	8000 70549	1	Piattello	Disc	Disque	Scheibe	Disco	
	8	8000 88822	1	Ass. gruppo frizione	Clutch group assy	Groupe embrayage compl.	Kupplungsgruppe Kpl.	Grupo embrague compl.	
	10	6BN0 21506	2	Sfera (7/32")	Ball (7/32")	Bille (7/32")	Kugel (7/32")	Esfera (7/32")	
	11	8000 70309	2	Astina	Rod	Tige	Stange	Varilla	
	12	8000 70552	1	Albero comando frizione	Shaft	Arbre	Welle	Eje	
	13	8000 70554	1	Molla	Spring	Ressort	Feder	Resorte	
	14	8000 55532	1	Bussola	Bushing	Douille	Buchse	Casquillo	
	15	8A00 31386	1	Dado	Nut	Ecrou	Mutter	Tuerca	
	16	8000 29089	1	Rosetta di sicurezza	Washer	Rondelle	Scheibe	Arandela	
	17	8000 70468	1	Mozzo portadischi	Clutch hub	Moyeu porte disque	Scheibenthalternabe	Porta discos	
	18	8000 46428	1	Rosetta	Washer	Rondelle	Scheibe	Arandela	
	19	8000 86163	1	Coppia ingranaggi primaria (Z 22/71)	Set of matched primary (Z 22/71)	Engrenages transmission primarie (Z 22/71)	Stirnraderpaar(Z 22/71)	Copla engranaje transmisiòn primaria (Z 22/71)	
	20	8A00 25044	2	Cuscinetto a rullini (ø24xØ28x10 mm)	Needle bearing (ø24xØ28x10 mm)	Roulement à aiguilles (ø24xØ28x10 mm)	Nadelkäfig (ø24xØ28x10 mm)	Cojinete (ø24xØ28x10 mm)	
	21	8A00 36849	1	Distanziale	Spacer	Entretoise	Distanzstück	Separador	
	22	8A00 65845	1	Distanziale	Spacer	Entretoise	Distanzstück	Separador	
	23	8000 92820	1	Distanziale	Spacer	Entretoise	Distanzstück	Separador	
	27	8000 54507	1	Linguetta a disco	Key	Clavette	Keil	Lengüeta americana	
	28	8000 86166	1	Custodia frizione	Clutch housing	Cage embrayage	Kupplungskorb	Campana embrague	
	29	8000 31378	6	Anello parastrappi	Flexible coupling	Parafente	Gummidämpfer	Paratirones	
	31	63N0 16349	6	Rivetto svasato	Rivet	Rivet	Niet	Remache	

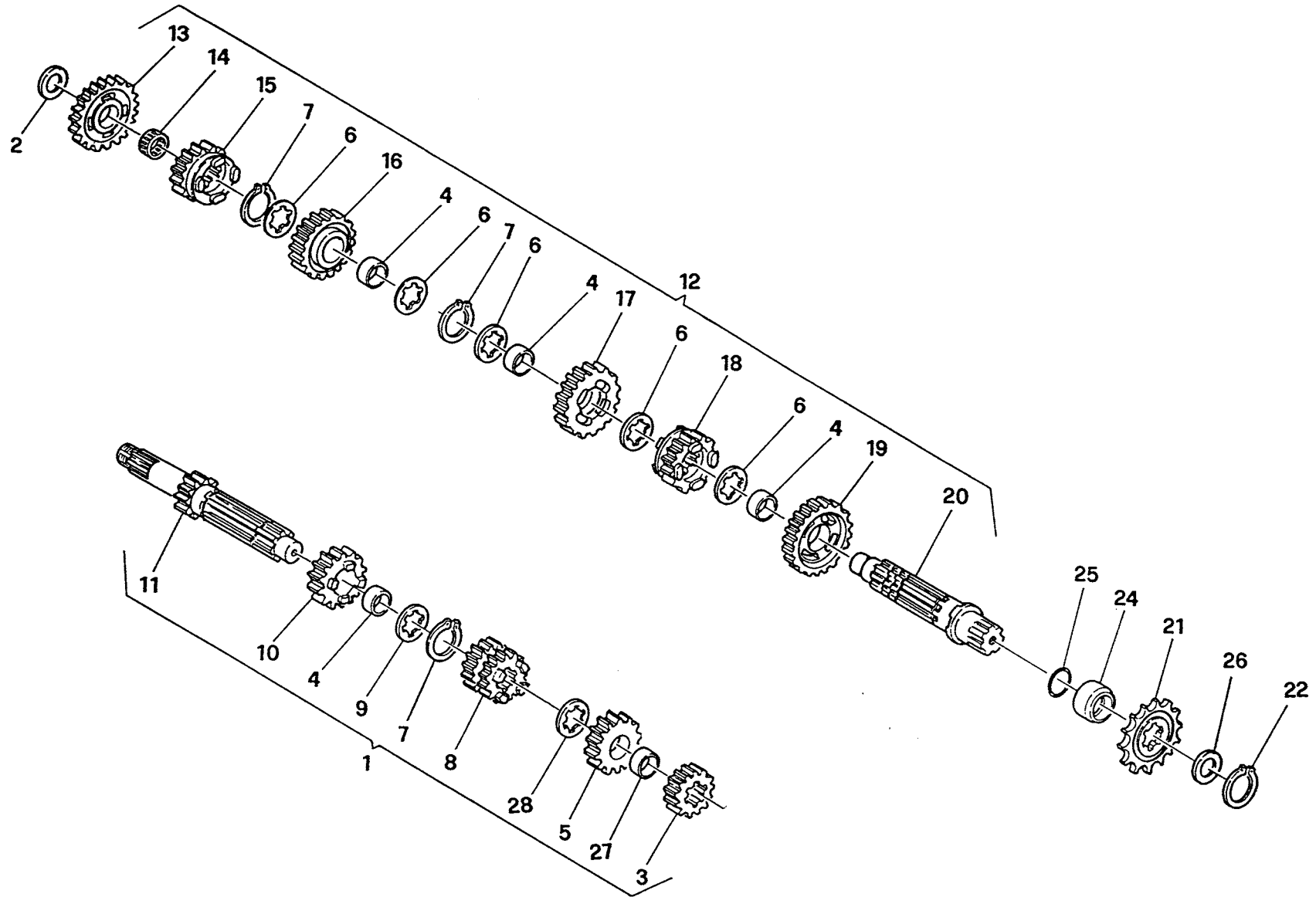

Note Notes Notas	Pos. No. N. Index Pos.	N. Cod. Code No. Nr. Code Code Nr N. Cod.	Q.tà Q.ty Q.te M.ge C.ad	DENOMINAZIONE	NAME	DESIGNATION	BESHREIBUNG	DENOMINACION	Validità Validity Validité Gültig Validez
	1	8000 99758	1	Assieme albero primario	Main shaft compl.	Arbre primaire compl.	Hauptwelle, Kpl.	Eje primario comp.	
	2	8C00 68860	1	Rosetta di rasamento (0,6 mm)	Washer (0,6 mm)	Rondelle (0,6 mm)	Scheibe (0,6 mm)	Arandela (0,6 mm)	
	2	8D00 68860	1	Rosetta di rasamento (0,8 mm)	Washer (0,8 mm)	Rondelle (0,8 mm)	Scheibe (0,8 mm)	Arandela (0,8 mm)	
	3	8000 99761	1	Ingr. seconda vel. A. P. (Z = 15)	Gear counter shaft 2nd(Z=15)	Engrenage 2ème A.P. (Z = 15)	Zahnrad 2 (Z = 15)	Engr. 2° velocidad (Z = 15)	
	4	8A00 61261	4	Bussola	Bush	Douille	Buchse	Casquillo	
	5	8000 83033	1	Ingr. sesta vel A. P. (Z = 21)	Gear, main shaft 6th (Z = 21)	Pignon 6ème A.P. (Z = 21)	Zahnrad 6 A.W. (Z = 21)	Engranaje 6 velocidad (Z=21)	
	6	8000 36023	5	Rosetta	Washer	Rondelle	Scheibe	Arandela	
	7	8000 31768	3	Anello elastico	Split ring	Anneau ressort	Sprengring	Anillo elástico	
	8	8000 A0301	1	Ingr. A.P. 3ª e 4ª (Z =19,20)	Gear shaft 3rd and 4 th speed (Z =19,20)	Engrenage 3ème et 4 éme (Z =19,20)	Zahnrad A.W. 3 u. 4. Gang (Z =19,20)	Engr. 3° y 4° velocidad (Z =16,18)	
	9	8000 36023	1	Rosetta	Washer	Rondelle	Scheibe	Arandela	
	10	8000 A0300	1	Ingr. quinta vel. A. P. (Z =22)	Gear, main shaft 5th (Z =22)	Pignon A.P. 5ème (Z =22)	Zahnrad 5 A.W. (Z =22)	Engranaje 5° velocidad (Z =22)	
	11	8000 99759	1	Albero primario (Z =14)	Main shaft (Z =14)	Arbre primaire (Z =14)	Hauptwelle (Z =14)	Eje primario (Z =14)	
	12	8000 A1908	1	Assieme albero secondario	Layshaft compl.	Arbre secondaire compl.	Vorgelegewelle, Kpl.	Eje secundario comp.	
	13	8000 99765	1	Ingr. prima vel. A. S. (Z =33)	Gear,counter shaft 1st (Z=33)	Pignon 1ère A.S. (Z =33)	Zahnrad 1 N.W. (Z =33)	Engr. 1° velocidad (Z =33)	
	14	8000 40449	1	Cuscinetto a rullini (ø16xØ20x10 mm)	Needle bearing (ø16xØ20x10 mm)	Roulement à aiguilles (ø16xØ20x10 mm)	Nadelkäfig (ø16xØ20x10 mm)	Cojinete (ø16xØ20x10 mm)	
	15	8000 99900	1	Ingr. quinta vel. A. S. (Z =26)	Gear counter shaft 5th(Z=26)	Pignon 5ème A.S.(Z =26)	Zahnrad 5 N.W.(Z =26)	Engr. 5° velocidad(Z =26)	
	16	8000 99872	1	Ingr. quarta vel. A. S.(Z =27)	Gear counter shaft 4th(Z=27)	Engrenage 4ème A.S.(Z =27)	Zahnrad 4 N.W.(Z =27)	Engr. 4° velocidad(Z =27)	
	17	8000 99818	1	Ingran. terza vel. A. S.(Z =30)	Gear counter shaft 3rd(Z=30)	Pignon 3ème A.S.(Z =30)	Zahnrad 3 N.W.(Z =30)	Engr. 3° velocidad(Z =30)	
	18	8000 83034	1	Ingr. sesta vel. A. S.(Z =21)	Gear counter shaft 6th(Z=21)	Pignon 6ème A.S.(Z =21)	Zahnrad 6 N.W.(Z =21)	Engr. 6° velocidad(Z =21)	
	19	8000 99763	1	Ingran. sec. vel. A. S.(Z =28)	Gear counter shaft 2nd(Z=28)	Pignon 2ème A.S.(Z =28)	Zahnrad 2 N.W.(Z =28)	Engr. 2° velocidad(Z =28)	
	20	8000 A1909	1	Albero secondario	Layshaft	Arbre secondaire	Vorgelegewelle	Eje secundario	
S	21	8A00 82469	1	Pignone uscita cambio (Z= 13)	Pinion (Z= 13)	Pignon (Z= 13)	Ritzel (Z= 13)	Piñón (Z= 13)	
R	21	8000 82469	1	Pignone uscita cambio (Z= 12)	Pinion (Z= 12)	Pignon (Z= 12)	Ritzel (Z= 12)	Piñón (Z= 12)	
R	21	8B00 82469	1	Pignone uscita cambio (Z= 14)	Pinion (Z= 14)	Pignon (Z= 14)	Ritzel (Z= 14)	Piñón (Z= 14)	
R	21	8C00 82469	1	Pignone uscita cambio (Z= 15)	Pinion (Z= 15)	Pignon (Z= 15)	Ritzel (Z= 15)	Piñón (Z= 15)	
	22	66NA 21208	1	Anello SEEGER	SEEGER ring	Anneau SEEGER	Ring SEEGER	Anillo SEEGER	
	24	8000 31744	1	Distanziale	Spacer	Entretoise	Distanzstück	Separador	
	25	8000 19789	1	Anello OR	O Ring	Bague OR	O Ring	Anillo OR	
	26	8E00 07989	1	Rosetta di rasamento (0,8 mm)	Washer (0,8 mm)	Rondelle (0,8 mm)	Scheibe (0,8 mm)	Arandela (0,8 mm)	
	26	8G00 07989	1	Rosetta di rasamento (1,0 mm)	Washer (1,0 mm)	Rondelle (1,0 mm)	Scheibe (1,0 mm)	Arandela (1,0 mm)	
	27	8000 66955	1	Bussola	Bush	Douille	Buchse	Casquillo	

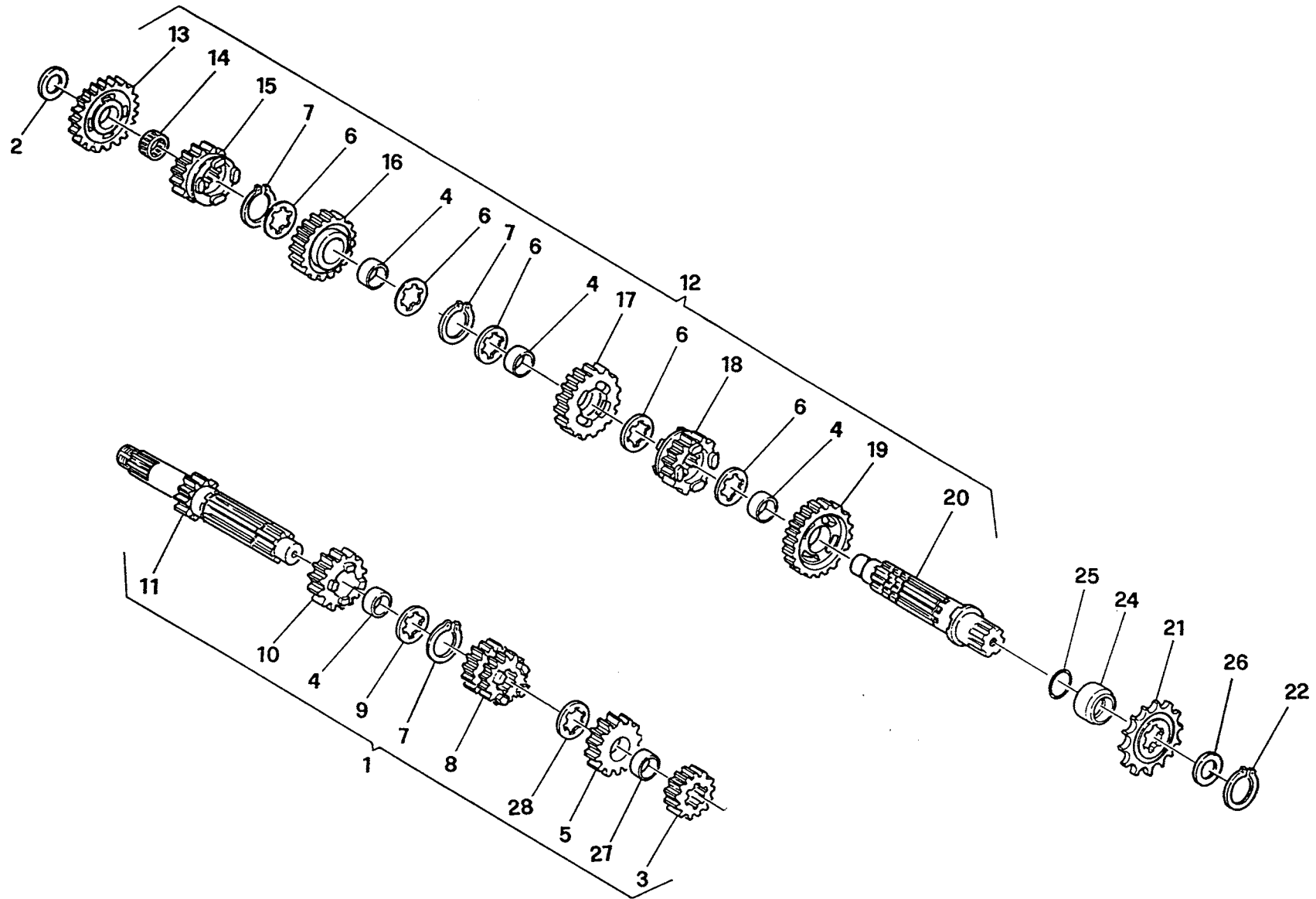





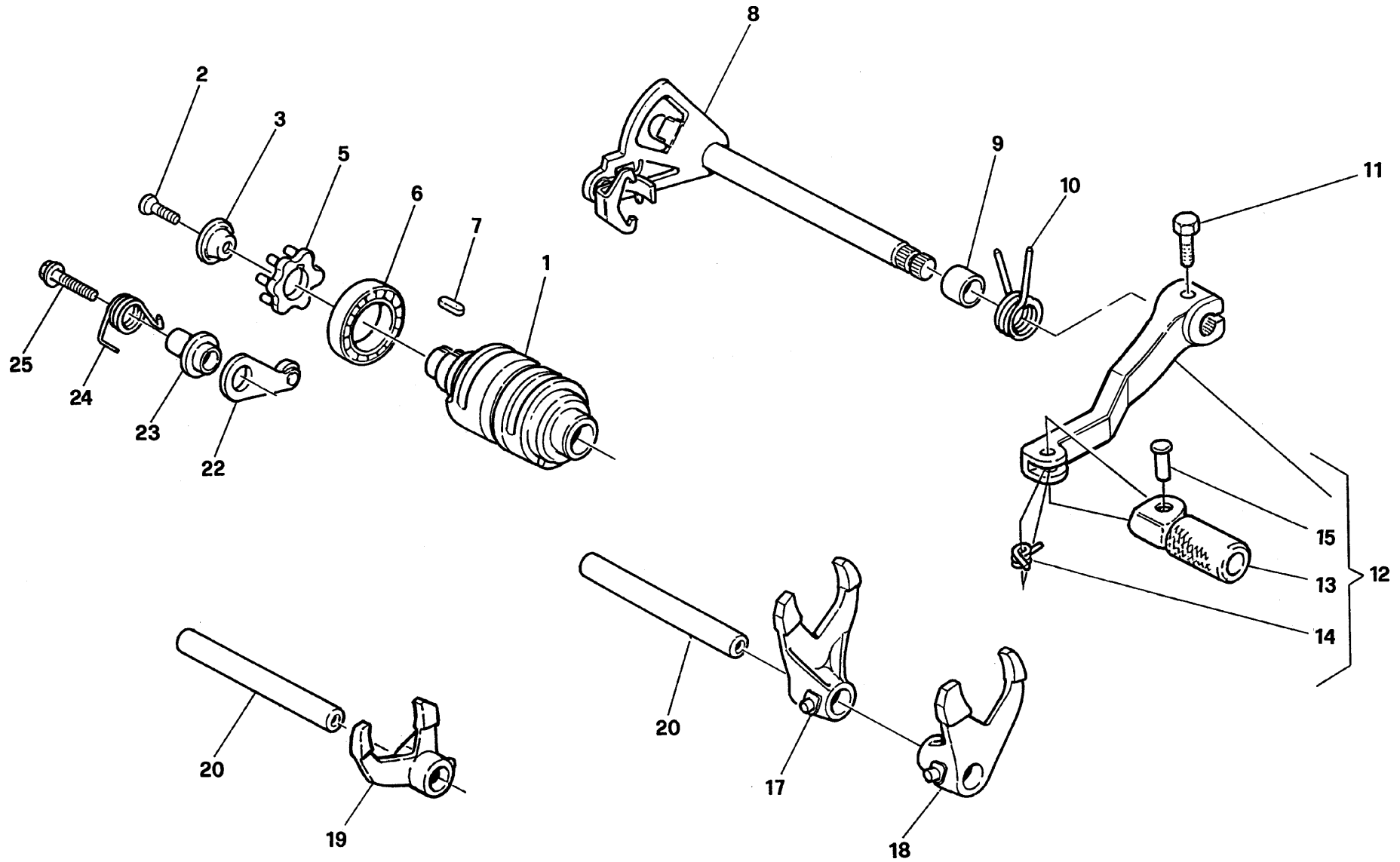

Note Notes Notes Marke Notas	Pos. No. N. Index Pos.	N. Cod. Code No. Nr. Code Code Nr N. Cod.	Q.tà Q.ty Q.te M.ge C.ad	DENOMINAZIONE	NAME	DESIGNATION	BESHREIBUNG	DENOMINACION	Validità Validity Validité Gültig Validez
	1	8000 83010	1	Albero comando forcelle	Fork driving shaft	Arbre de commande fourche	Steuerwelle f. Gabel	Eje mando horquilla	
	2	8000 26970	1	Vite	Screw	Vis	Schraube	Tornillo	
	3	8000 38708	1	Rosetta	Washer	Rondelle	Scheibe	Arandela	
	5	8000 38706	1	Rocchetto	Sprocket	Rochet	Spule	Piñon	
	6	8000 65884	1	Cuscinetto a sfere (ø25xØ37x7 mm)	Ball bearing (ø25xØ37x7 mm)	Roulement à billes (ø25xØ37x7 mm)	Kugellager (ø25xØ37x7 mm)	Cojinete de bolas (ø25xØ37x7 mm)	
	7	8000 38707	1	Linguetta	Woodruff key	Clé woodruff	Federkeil	Lengüeta	
	8	8000 65975	1	Assieme selettore	Selector assembly	Ensemble sélecteur	Aggregat Wählschalter	Juego selector	
	9	8A00 46226	1	Distanziale	Spacer	Entretoise	Distanzstück	Separador	
	10	8000 46225	1	Molla	Spring	Ressort	Feder	Resorte	
	11	8000 62728	1	Vite	Screw	Vis	Schraube	Tornillo	
E	12	8000 99741	1	Assieme leva comando cambio	Crank lever assy	Levier compl.	Hebel kpl.	Pedal mando cambio compl.	
	12	8000 A3488	1	Assieme leva comando cambio	Crank lever assy	Levier compl.	Hebel kpl.	Pedal mando cambio compl.	
E	13	8000 A3485	1	Pedalino	Pedal	Pedale	Pedal	Pedal	
	13	8A00 A3485	1	Pedalino	Pedal	Pedale	Pedal	Pedal	
	14	8000 70216	1	Molla	Spring	Ressort	Feder	Resorte	
	15	8000 99744	1	Ribattino	Rivet	Rivet	Niet	Remache	
	17	8000 67010	1	Forcella com. ingr. 1ª, 4ª vel.	Fork gear shifter 1st, 4th	Fourche 1ère, 4ème	Schaltgabel 1. 4. Gang	Horquilla compl. engr. 1°, 4°	
	18	8A00 67011	1	Forcella ingr 2ª e 3ª veloc.	2nd & 3rd gear control fork	Fourche c.de 2ème & 3ème	Gabel f. Zahnr. 2. & 3. Gesch.	Horquilla engr. 2° y 3° vel.	
	19	8000 67012	1	Forcella ingr.5ª e 6ª velocità	5th & 6th gear control fork	Fourche c.de 5ème & 6ème	Gabel f. Zahnr. 5. & 6. Gesch.	Horquilla engr. 5° y 6° vel.	
	20	8000 35876	2	Perno forcella	Pin	Pivot	Stift	Perno	
	22	8A00 65895	1	Saltarello fissa marce	Gear fixing click	Cliquet	Strumhaken	Salt. fijo marchas	
	23	8000 66962	1	Bussola	Bushing	Douille	Buchse	Manguito	
	24	8000 65921	1	Molla	Spring	Ressort	Feder	Resorte	
	25	8000 62730	1	Vite	Screw	Vis	Schraube	Tornillo	

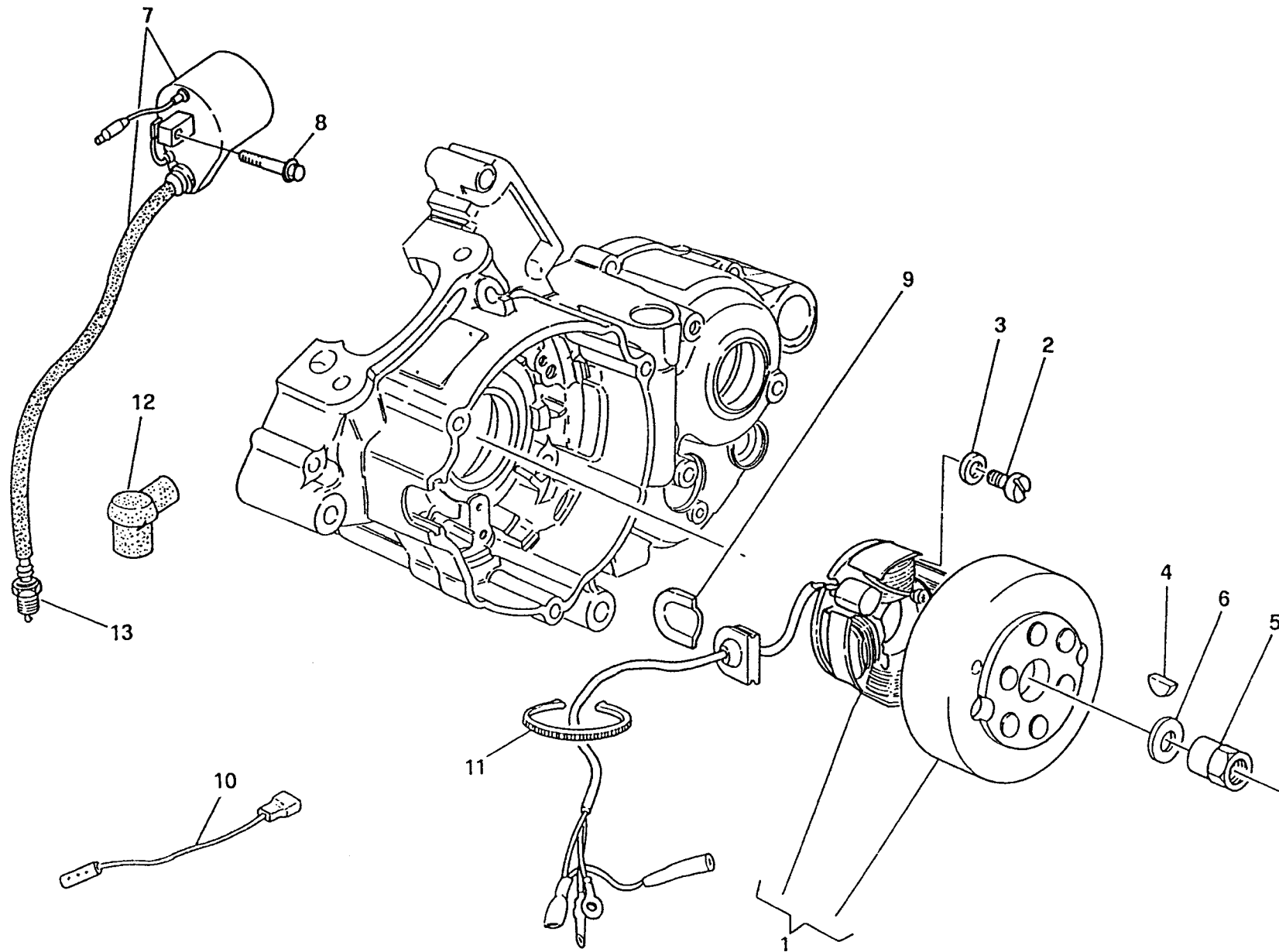

Note Notes Notes Marke Notas	Pos. No. N. Index Pos.	N. Cod. Code No. Nr. Code Code Nr N. Cod.	Q.tà Q.ty Q.te M.ge C.ad	DENOMINAZIONE	NAME	DESIGNATION	BESCHREIBUNG	DENOMINACION	Validità Validity Validité Gültig Validez
	1	8000 67029	1	Alternatore completo	Alternator compl.	Alternateur compl.	Lichtmaschine kpl.	Alternador compl.	
	2	8000 82496	2	Vite	Screw	Vis	Schraube	Tornillo	
	3	8000 38291	2	Rosetta	Washer	Rondelle	Scheibe	Arandela	
	4	65N0 21002	1	Linguetta americana	Woodruff key	Clé woodruff	Federkeil	Lengüeta americana	
	5	8000 73540	1	Dado	Nut	Ecrou	Mutter	Tuerca	
	6	8000 73593	1	Rosetta	Washer	Rondelle	Scheibe	Arandela	
	7	8000 66418	1	Bobina	Coil	Bobine	Zundspule	Bobina	
	8	8000 62727	2	Vite	Screw	Vis	Schraube	Tornillo	
	9	8000 76079	1	Piastrina	Plate	Plaque	Platte	Placa	
U	10	8000 91965	1	Cavo regolatore-bobina	Voltage rectifier-coil cable	Cable regulateur-bobine	Spannungregler-Zundspule Kabel	Cable regulator-bobina	
	11	8000 56444	4	Fascetta (L= 188 mm)	Clamp (L= 188 mm)	Collier (L= 188 mm)	Schelle (L= 188 mm)	Abrazadera (L= 188 mm)	
	12	8000 90877	1	Pipetta	Pipette	Pipette	Pipette	Pipa	
	12	8000 75270	1	Pipetta (NGK)	Pipette (NGK)	Pipette (NGK)	Pipette (NGK)	Pipa (NGK)	
	13	8A00 57446	1	Candela	Spark plug	Bougie	Zundkerze	Bujia	
A	13	8000 88759	1	Candela	Spark plug	Bougie	Zundkerze	Bujia	

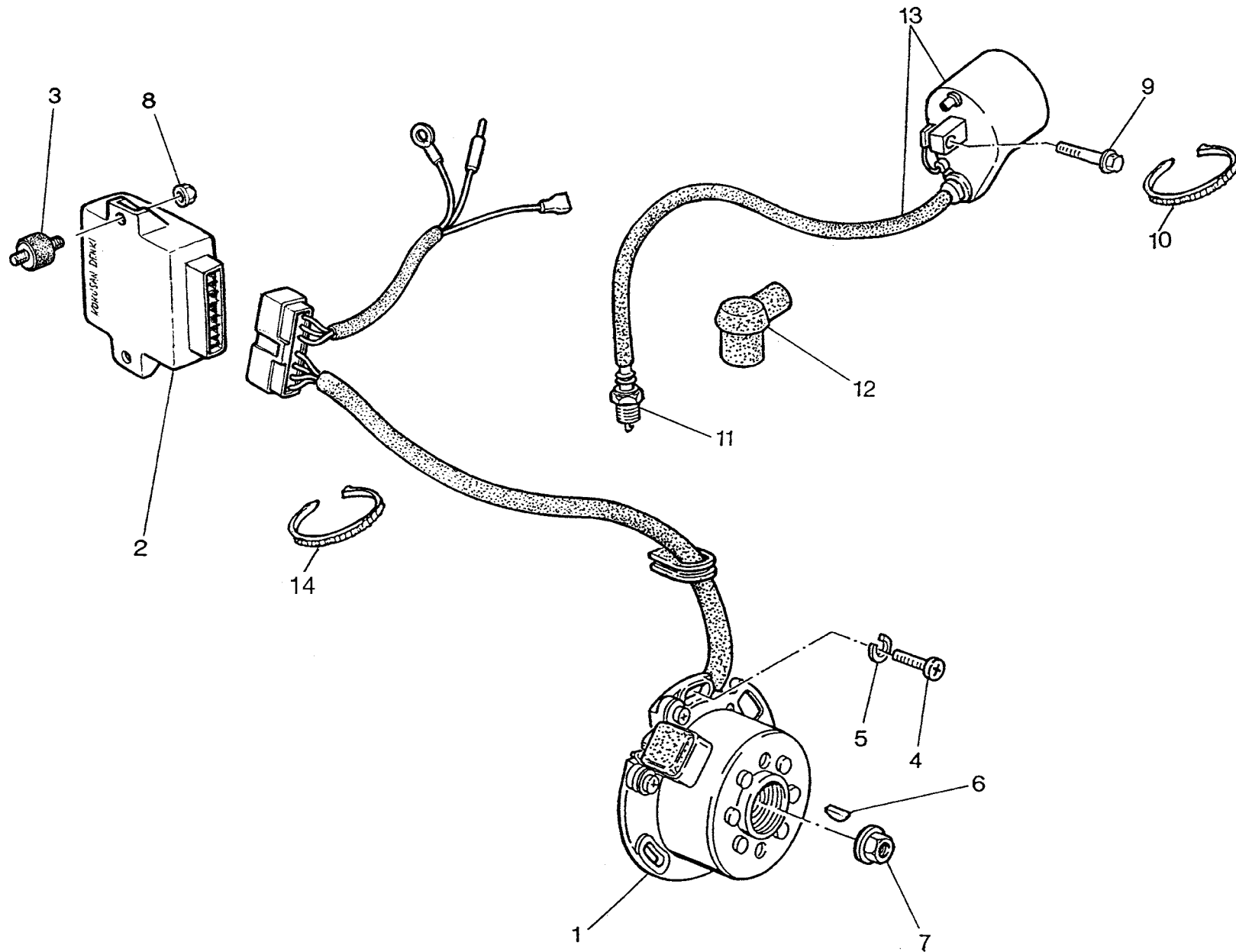

Note Notes Notes Marke Notas	Pos. No. N. Index Pos.	N. Cod. Code No. Nr. Code Code Nr N. Cod.	Q.tà Q.ty Q.te M.ge C.ad	DENOMINAZIONE	NAME	DESIGNATION	BESCHREIBUNG	DENOMINACION	Validità Validity Validité Gültig Validez
	1	8000 86796	1	Alternatore completo	Alternator compl.	Alternateur compl.	Lichtmaschine kpl.	Alternador compl.	
	2	8000 83087	1	Centralina elettronica	Electronic device	Dispositif électronique	Zundelektronik	Centralita electronica	
	3	8000 90012	2	Silent-block	Silent-block	Silent-block	Silent-block	Silent-block	
	4	8000 62727	2	Vite	Screw	Vis	Schraube	Tornillo	
	5	62N1 15504	2	Rosetta	Washer	Rondelle	Scheibe	Arandela	
	6	65N0 21002	1	Linguetta americana	Woodruff key	Clé woodruff	Federkeil	Lengueta americana	
	7	8000 42023	1	Dado	Nut	Ecrou	Mutter	Tuerca	
	8	8000 44240	2	Dado	Nut	Ecrou	Mutter	Tuerca	
	9	8000 62727	2	Vite	Screw	Vis	Schraube	Tornillo	
	10	8000 56444	5	Fascetta (L= 188 mm)	Clamp (L= 188 mm)	Collier (L= 188 mm)	Schelle (L= 188 mm)	Banda (L= 188 mm)	
	11	8000 88759	1	Candela	Spark plug	Bougie	Zundkerze	Bujías	
A	11	8A00 57446	1	Candela	Spark plug	Bougie	Zundkerze	Bujías	
	12	8000 90877	1	Pipetta schermata	Plug pipe	Pipette bougie	Kerzenstecker	Pipa bujía	
P	12	8000 75270	1	Pipetta	Plug pipe	Pipette bougie	Kerzenstecker	Pipa bujía	
	13	8000 72887	1	Bobina	Coil	Bobine	Zundspule	Bobina	
	14	8000 92248	4	Fascetta (L= 82 mm)	Clamp (L= 82 mm)	Collier (L= 82 mm)	Schelle (L= 82 mm)	Abrazadera (L= 82 mm)	
P				Accoppiare con particolare 8A0057446 pos.11	Coupling with part. 8A0057446 No.11	Fournir ensemble à part 8A0057446 N.11	Geliefer mit Teile 8A0057446 Index 11	Equipar acoplado al part. 8A0057446 pos.11	



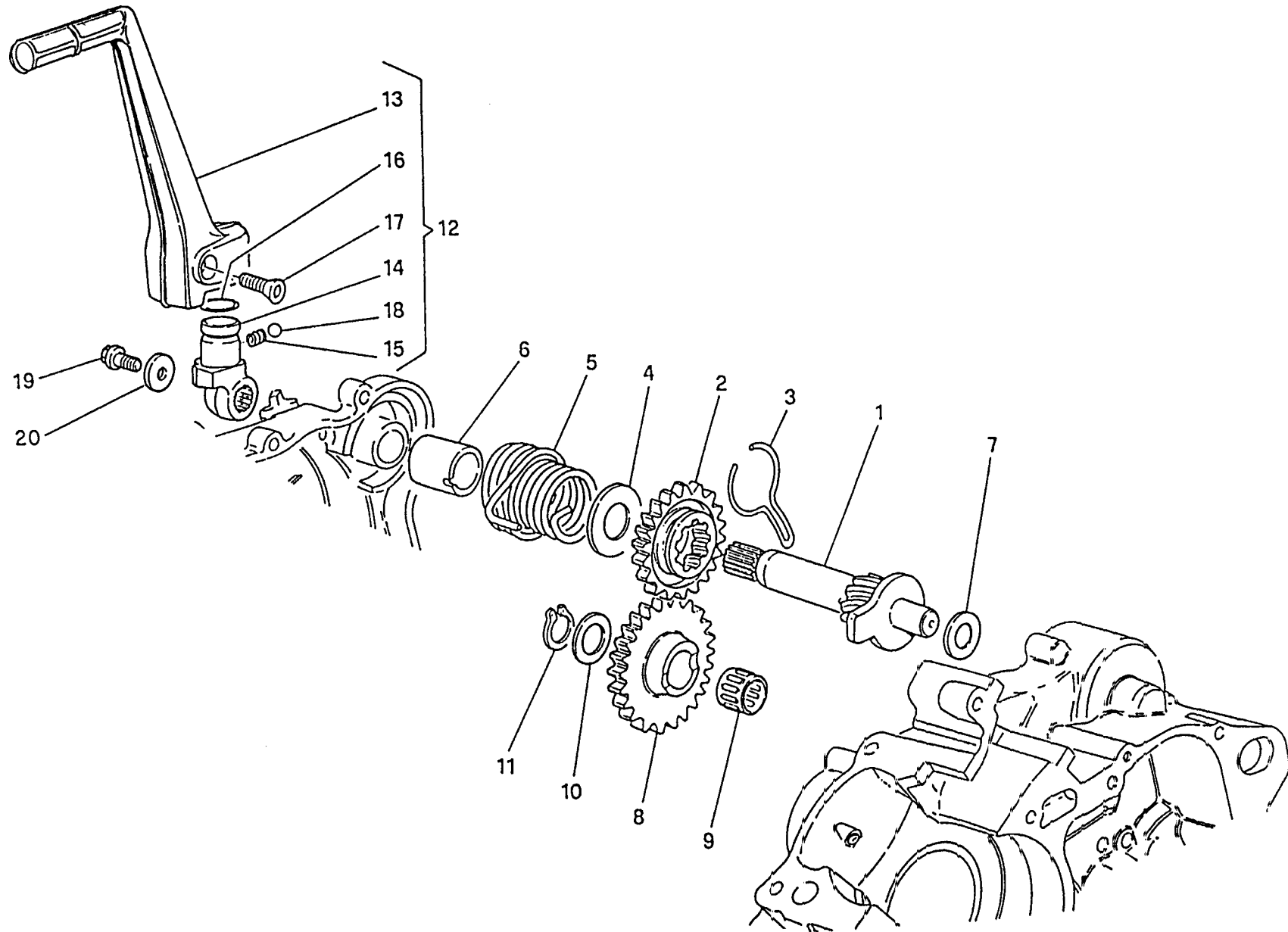

Note Notes Notas	Pos. No. N. Index Pos.	N. Cod. Code No. Nr. Code Code Nr N. Cod.	Q.tà Q.ty Q.te M.ge C.ad	DENOMINAZIONE	NAME	DESIGNATION	BESHREIBUNG	DENOMINACION	Validità Validity Validité Gültig Validez
	1	8000 67017	1	Albero avviamento	Starter crank shaft	Arbre de démarrage	Kickstarterwelle	Eje arranque	
	2	8000 67015	1	Ingranaggio (Z = 22)	Gear (Z = 22)	Engrenage (Z = 22)	Zahnrad (Z = 22)	Engranaje (Z = 22)	
	3	8000 67016	1	Molla di frizione	Spring	Resort	Feder	Resorte	
	4	8E00 18282	1	Rosetta	Washer	Rondelle	Scheibe	Arandela	
	5	8000 83095	1	Molla di ritorno leva	Spring	Resort	Feder	Resorte	
	6	8000 67020	1	Distanziale	Spacer	Entretoise	Distanzstück	Separador	
	7	8D00 10789	1	Rosetta	Washer	Rondelle	Scheibe	Arandela	
	8	8000 67013	1	Ingranaggio di rinvio (Z = 25)	Gear (Z = 25)	Engrenage (Z = 25)	Zahnrad (Z = 25)	Engranaje (Z = 25)	
	9	8A00 19946	1	Cuscinetto a rulli (ø14xØ18x8 mm)	Needle bearing (ø14xØ18x8 mm)	Roulement à l'aiguilles (ø14xØ18x8 mm)	Nadelkafig (ø14xØ18x8 mm)	Cojinete (ø14xØ18x8 mm)	
	10	8E00 01049	1	Rosetta	Washer	Rondelle	Scheibe	Arandela	
	11	66N0 21203	1	Anello elastico	Split ring	Anneau ressort	Sprengring	Anillo elástico	
	12	8000 67045	1	Leva avviamento completa	Starter lever assy	Levier démarrage compl.	Hebelanlasser kpl.	Palanca arranque compl.	
	13	8000 74415	1	Leva avviamento	Lever	Levier	Hebelanlasser	Palanca	
	14	8000 67047	1	Mozzetto	Hub	Moyeau	Radnabe	Cubo	
	15	8000 66946	1	Molla	Spring	Ressort	Feder	Resorte	
	16	8000 36380	1	Anello OR	Ring	Anneau OR	RING OR	Anillo OR	
	17	8A00 38287	1	Vite	Screw	Vis	Scchraube	Tornillo	
	18	6BN0 21506	1	Sfera (7/32")	Ball (7/32")	Bille (7/32")	Kugel (7/32")	Esfera (7/32")	
	19	8000 62725	1	Vite	Screw	Vis	Scchraube	Tornillo	
	20	8000 30319	1	Rosetta	Washer	Rondelle	Scheibe	Arandela	

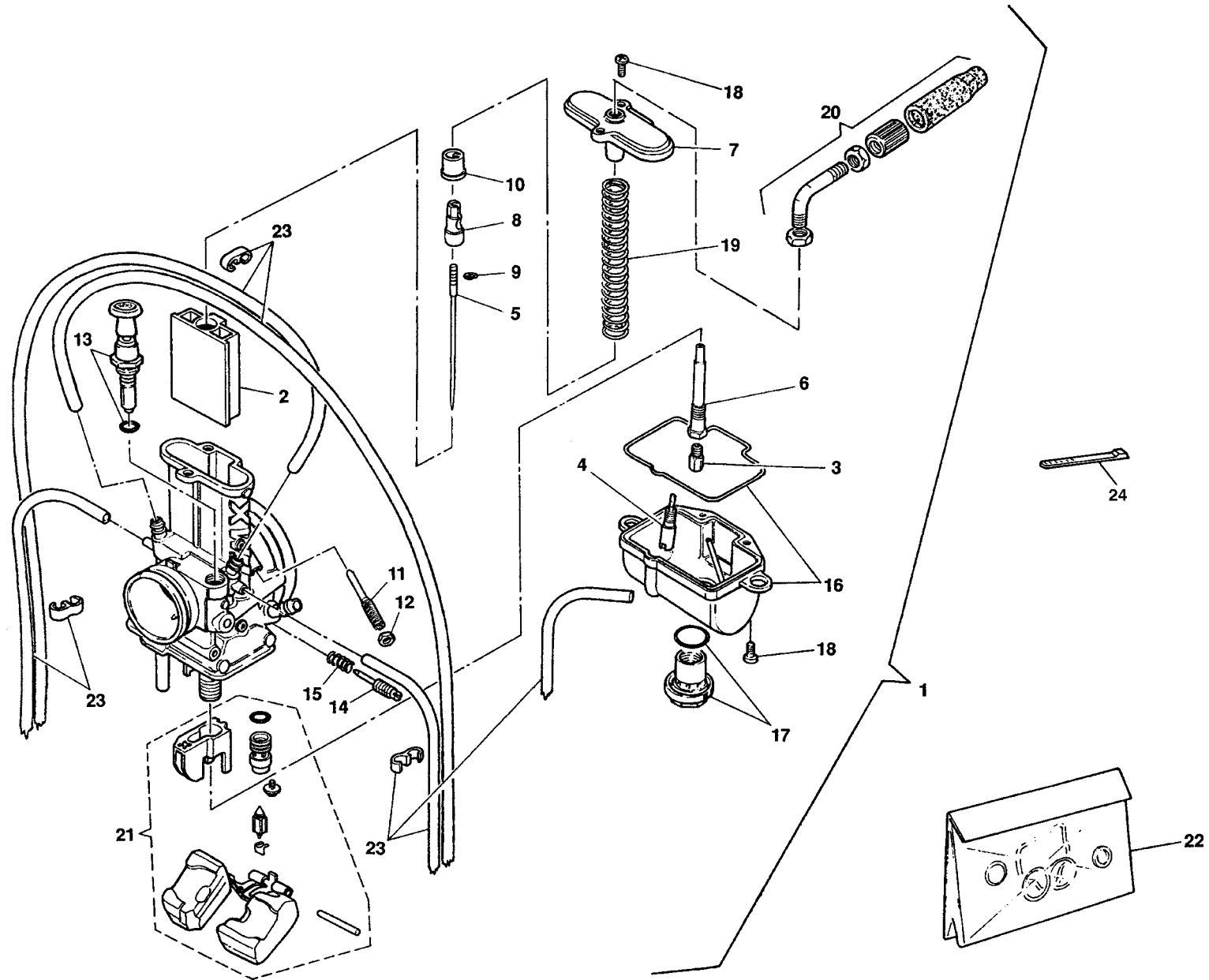

Note Notes Notes Marke Notas	Pos. No. N. Index Pos.	N. Cod. Code No. Nr. Code Code Nr N. Cod.	Q.tà Q.ty Q.te M.ge C.ad	DENOMINAZIONE	NAME	DESIGNATION	BESHREIBUNG	DENOMINACION	Validità Validity Validité Gültig Validez
	1	8000 86838	1	Assieme carburatore	Carburetor assy	Carburateur compl.	Vergaser kpl.	Carburador compl.	
	2	8000 86918	1	Valvola gas (3.0)	Throttle valve (3.0)	Papillon de gaz (3.0)	Drosselklappe (3.0)	Válvula (3.0)	
R	2	8A00 86918	1	Valvola gas (2.5)	Throttle valve (2.5)	Papillon de gaz (2.5)	Drosselklappe (2.5)	Válvula (2.5)	
R	2	8B00 86918	1	Valvola gas (3.5)	Throttle valve (3.5)	Papillon de gaz (3.5)	Drosselklappe (3.5)	Válvula (3.5)	
	3	8W00 72310	1	Getto max. (400)	Main jet (400)	Gicleur principal (400)	Hauptdüse (400)	Chiclé máximo (400)	
DC	3	8S00 72310	1	Getto max. (360)	Main jet (360)	Gicleur principal (360)	Hauptdüse (360)	Chiclé máximo (360)	
D	3	8T00 72310	1	Getto max. (370)	Main jet (370)	Gicleur principal (370)	Hauptdüse (370)	Chiclé máximo (370)	
D	3	8U00 72310	1	Getto max. (380)	Main jet (380)	Gicleur principal (380)	Hauptdüse (380)	Chiclé máximo (380)	
D	3	8V00 72310	1	Getto max. (390)	Main jet (390)	Gicleur principal (390)	Hauptdüse (390)	Chiclé máximo (390)	
D	3	8X00 72310	1	Getto max. (410)	Main jet (410)	Gicleur principal (410)	Hauptdüse (410)	Chiclé máximo (410)	
R	3	8Y00 72310	1	Getto max. (420)	Main jet (420)	Gicleur principal (420)	Hauptdüse (420)	Chiclé máximo (420)	
R	3	8Z00 72310	1	Getto max. (430)	Main jet (430)	Gicleur principal (430)	Hauptdüse (430)	Chiclé máximo (430)	
	4	8B00 A1804	1	Getto minimo (35)	Idle jet (35)	Gicleur minimum (35)	Leerlaufdüse (35)	Chiclé mínimo (35)	
D	4	8000 A1804	1	Getto minimo (30)	Idle jet (30)	Gicleur minimum (30)	Leerlaufdüse (30)	Chiclé mínimo (30)	
D	4	8L00 A1804	1	Getto minimo (40)	Idle jet (40)	Gicleur minimum (40)	Leerlaufdüse (40)	Chiclé mínimo (40)	
	5	8000 86920	1	Spillo conico (60)	Needle (60)	Pointeau conique (60)	Kon. Nadel (60)	Pasador cónico (60)	
DC	5	8C00 86920	1	Spillo conico (58)	Needle (58)	Pointeau conique (58)	Kon. Nadel (58)	Pasador cónico (58)	
D	5	8A00 86920	1	Spillo conico (59)	Needle (59)	Pointeau conique (59)	Kon. Nadel (59)	Pasador cónico (59)	
R	5	8B00 86920	1	Spillo conico (61)	Needle (61)	Pointeau conique (61)	Kon. Nadel (61)	Pasador cónico (61)	
	6	8000 86921	1	Polverizzatore	Fuel nozzle	Pulvérisateur	Einspritzdüse	Pulverizadør	
DC	6	8A00 86921	1	Polverizzatore R8	Fuel nozzle R8	Pulvérisateur R8	Einspritzdüse R8	Pulverizadør R8	
	7	8000 86932	1	Coperchio	Cover	Couvercle	Deckel	Tapa	
	8	8000 86978	1	Fermo spillo e molla	Retainer	Arrêt	Klammer	Pasadør	
	9	8000 72323	1	Anello SEEGER	SEEGER ring	Anneau SEEGER	Ring SEEGER	Anillo SEEGER	
	10	8000 86925	1	Guida molla	Spring seat	Siège ressort	Feder sitzring	Alojamiento resorte	
	11	8000 86926	1	Vite aria	Screw	Vis	Schraube	Tornillo	
	12	8000 86927	1	Dado	Nut	Ecrou	Mutter	Tuerca	
	13	8000 72327	1	Dispositivo avviamento	Starting device	Dispositif de démarrage	Startvorrichtung	Dispositivo puesta en marcha	
	14	8000 72328	1	Vite minimo	Screw	Vis	Schraube	Tornillo	
	15	8000 72329	1	Molla	Spring	Ressort	Feder	Resorte	
	16	8000 86928	1	Vaschetta	Chamber	Cuvette	Becken	Cubeta	
	17	8000 72331	1	Dado	Nut	Ecrou	Mutter	Tuerca	
	18	8000 86979	1	Vite	Screw	Vis	Schraube	Tornillo	

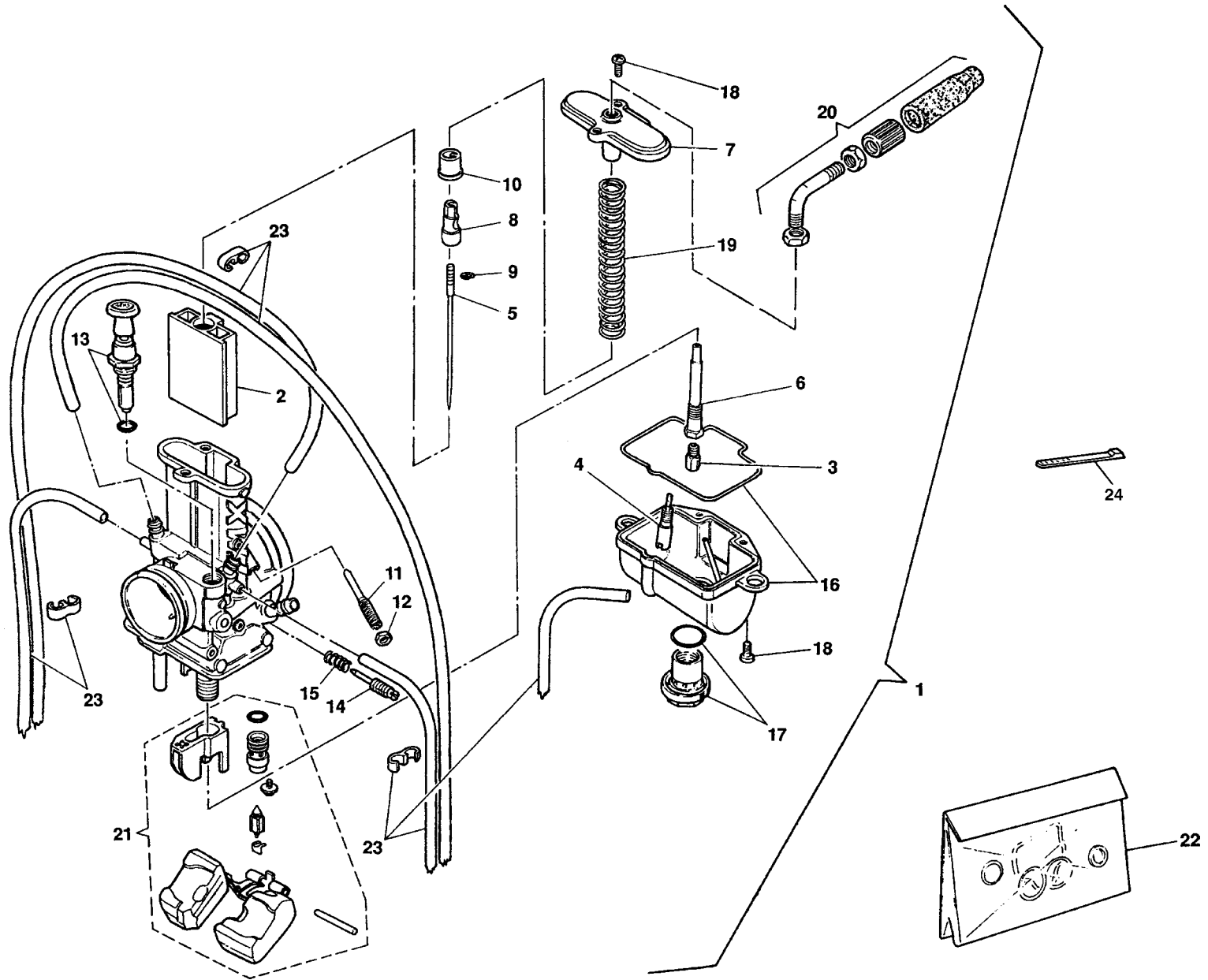





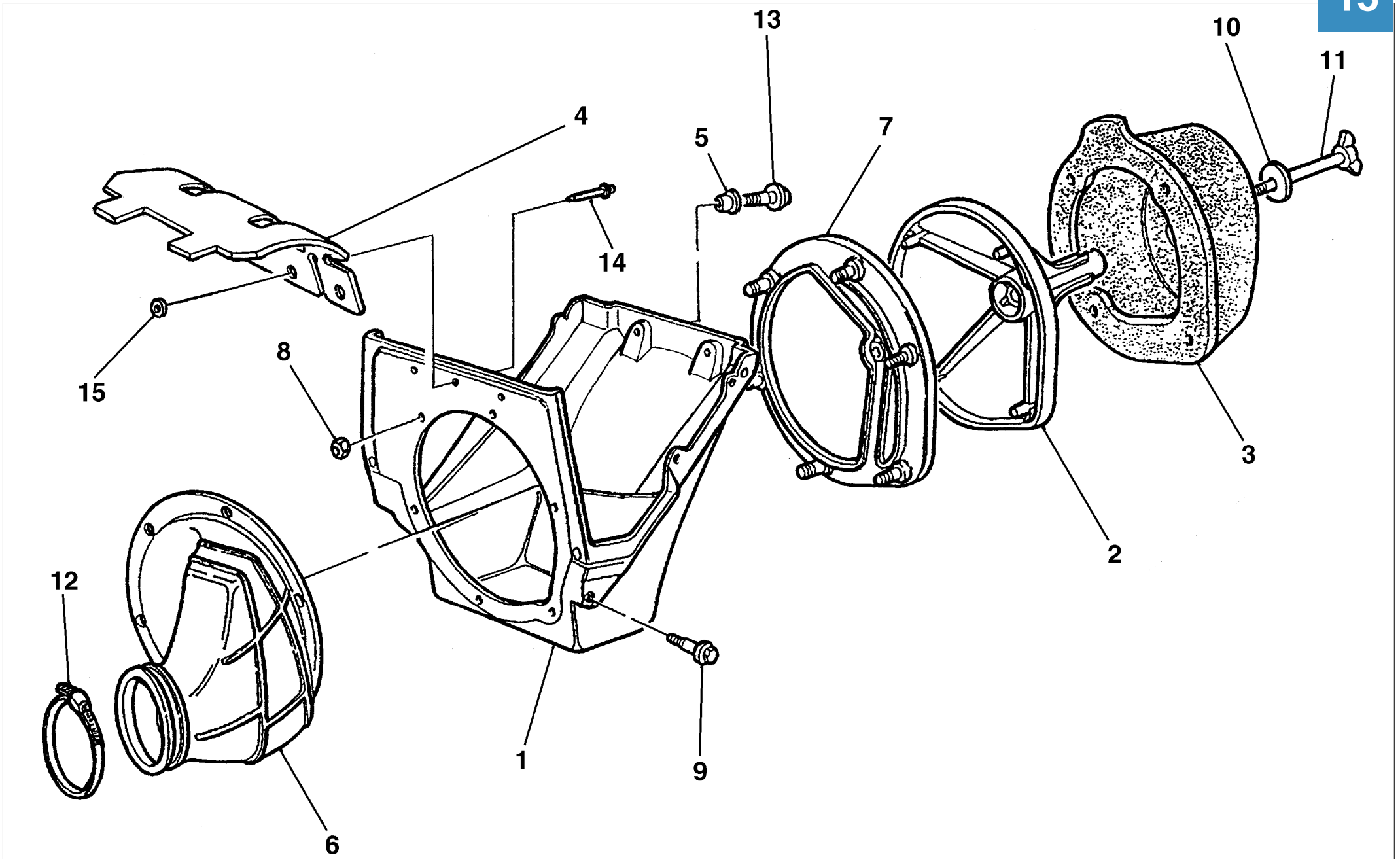

Note Notes Notes Marke Notas	Pos. No. N. Index Pos.	N. Cod. Code No. Nr. Code Code Nr N. Cod.	Q.tà Q.ty Q.te M.ge C.ad	DENOMINAZIONE	NAME	DESIGNATION	BESCHREIBUNG	DENOMINACION	Validità Validity Validité Gültig Validez
	1	80A0 91792	1	Scatola filtro aria	Air filter box	Boîte filtre	Filterkasten	Caja filtro aire	
	2	8000 69549	1	Gabbia filtro	Cleaner cage	Cage pour filtre	Filterkafig	Caja filtro	
	3	8000 72641	1	Filtro aria	Air filter	Filtre à air	Luftfilter	Filtro aire	
	4	8000 95898	1	Protezione	Guard	Protection	Schutz	Protección	
	5	8000 69429	2	Bussola	Bushing	Duille	Buchse	Manguito	
WU	6	8C00 73623	1	Raccordo	Union	Raccord	Anschluss	Empalme	
C	6	8000 A2774	1	Raccordo	Union	Raccord	Anschluss	Empalme	
AC	6	8000 86888	1	Raccordo	Union	Raccord	Anschluss	Empalme	
	7	8000 70024	1	Flangia	Flange	Bride	Flansch	Brida	
	8	8000 40718	6	Dado	Nut	Ecrou	Mutter	Tuerca	
	9	8000 62726	2	Vite	Screw	Vis	Schraube	Tornillo	
	10	62N1 15549	1	Rosetta piana	Washer	Rondelle	Scheibe	Arandela	
	11	8A00 37947	1	Vite	Screw	Vis	Schraube	Tornillo	
	12	8E00 99475	1	Fascetta	Clamp	Collier	Schelle	Banda	
	13	8000 62728	2	Vite	Screw	Vis	Schraube	Tornillo	
	14	8000 33372	5	Rivetto	Rivet	Rivet	Niet	Remache	
	15	62N1 15547	5	Rosetta piana	Washer	Rondelle	Scheibe	Arandela	

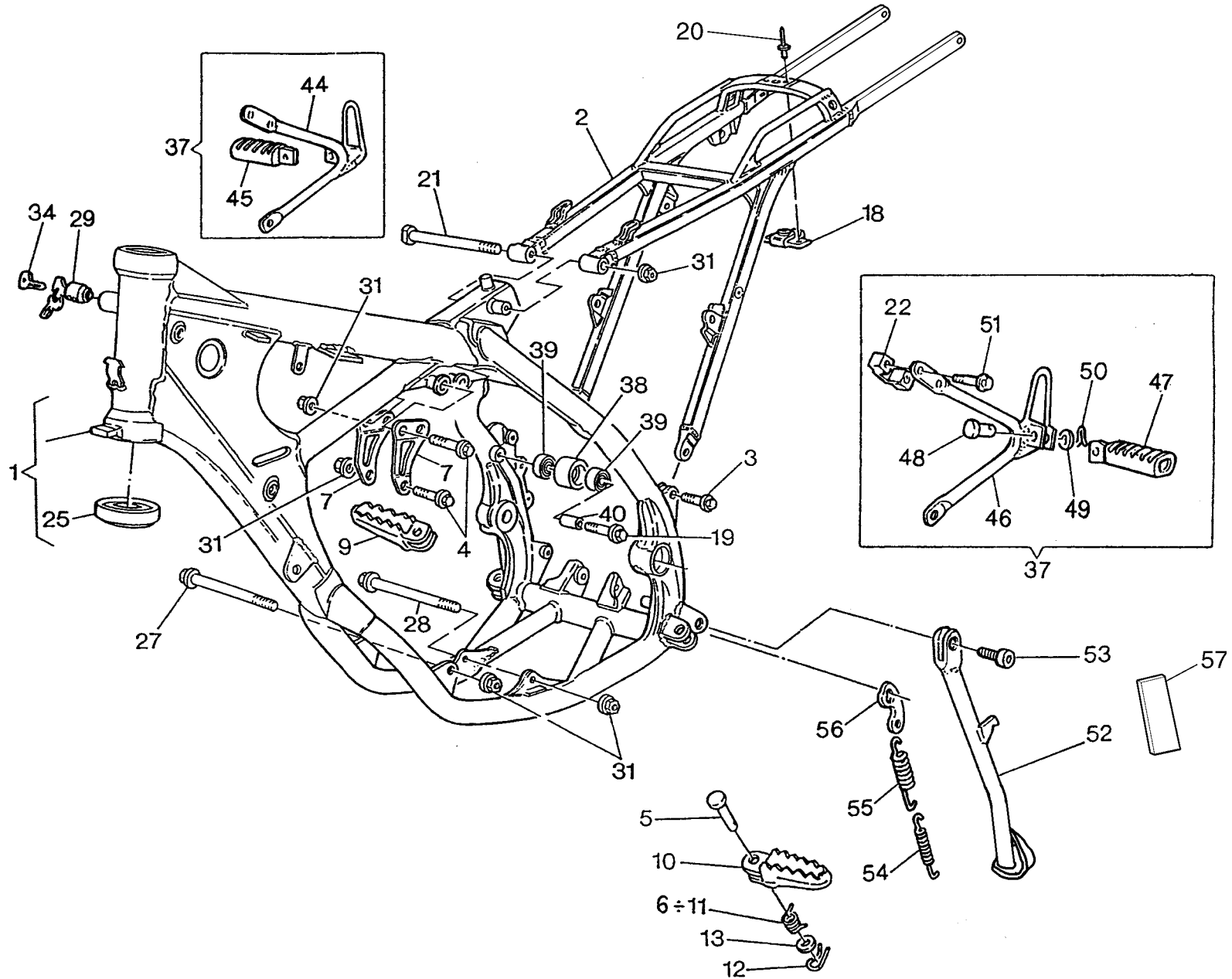

Note Notes Marke Notas	Pos. No. N. Index Pos.	N. Cod. Code No. Nr. Code Code Nr N. Cod.	Q.tà Q.ty Q.te M.ge C.ad	DENOMINAZIONE	NAME	DESIGNATION	BESHREIBUNG	DENOMINACION	Validità Validity Validité Gültig Validez
W	1	8A00 96954	1	Parte anteriore completa	Frame front side assy	Chassis av. compl.	Rahmen kpl.	Cuadro anterior compl.	
C	1	8A00 96895	1	Parte anteriore completa	Frame front side assy	Chassis av. compl.	Rahmen kpl.	Cuadro anterior compl.	
U	1	8E00 96954	1	Parte anteriore completa	Frame front side assy	Chassis av. compl.	Rahmen kpl.	Cuadro anterior compl.	
	2	8000 A4098	1	Parte posteriore telaio	Rear frame side	Chassis arrière	Sattelbrücke	Cuadro posterior	
	3	8000 69056	2	Vite (M8x20 mm)	Screw (M8x20 mm)	Vis (M8x20 mm)	Schraube (M8x20 mm)	Tornillo (M8x20 mm)	
	4	8000 62795	3	Vite (M8x50 mm)	Screw (M8x50 mm)	Vis (M8x50 mm)	Schraube (M8x50 mm)	Tornillo (M8x50 mm)	
	5	8000 73140	2	Perno	Pin	Goupille	Stift	Clavija	
	6	8000 96907	1	Molla Sx	L.H. spring	Ressort G.	Feder L.	Resorte Iz.	
	7	8000 73830	2	Piastra fissaggio motore	Plate	Plaque	Platte	Placa	
	9	80A0 89953	1	Pedana destra	R.H. foot-rest	Repose-pieds D.	R. Fussraste	Pedal delnt. derech. compl.	
	10	80A0 89962	1	Pedana sinistra	L.H. foot-rest	Repose-pieds G.	L. Fussraste	Pedal delant. izrdo. compl.	
	11	8000 96908	1	Molla Dx	R.H. spring	Ressort D.	Feder R.	Resorte Der.	
	12	64N1 20068	2	Copiglia	Split pin	Goupille	Splint	Clavija	
	13	8A00 01815	2	Rosetta	Washer	Rondelle	Scheibe	Arandela	
	18	8000 69150	1	Piastrina	Plate	Plaquette	Plättchen	Placa	
	19	8000 62796	2	Vite (M8x40 mm)	Screw (M8x40 mm)	Vis (M8x40 mm)	Schraube (M8x40 mm)	Tornillo (M8x40 mm)	
	20	8000 33373	2	Rivetto	Rivet	Rivet	Niet	Remache	
	21	8000 69111	1	Vite (M8x130 mm)	Screw (M8x130 mm)	Vis (M8x130 mm)	Schraube (M8x130 mm)	Tornillo (M8x130 mm)	
XYD	22	8000 71091	2	Cavallotto	U-bolt	Cavalier	Bügelbolzen	Caballote	
WU	25	1513 07001	2	Cuscinetto a rulli conici (ø25xø50x17,5 mm)	Bearing (ø25xø50x17,5 mm)	Roulement à rouleaux coniques (ø25xø50x17,5 mm)	Lager (ø25xø50x17,5 mm)	Cojinete de rodillos cónicos (ø25xø50x17,5 mm)	
C	25	8000 87243	2	Cuscinetto a rulli conici (ø29xø48x17,5 mm)	Bearing (ø29xø48x17,5 mm)	Roulement à rouleaux coniques (ø29xø48x17,5 mm)	Lager (ø29xø48x17,5 mm)	Cojinete de rodillos cónicos (ø29xø48x17,5 mm)	
	27	8N00 73458	1	Perno ant. fiss. motore (M8x120 mm)	Pin (M8x120 mm)	Pivot (M8x120 mm)	Bolzen (M8x120 mm)	Perno (M8x120 mm)	
	28	8P00 73458	1	Perno inf. fiss. motore (M8x135 mm)	Pin (M8x135 mm)	Pivot (M8x135 mm)	Bolzen (M8x135 mm)	Perno (M8x135 mm)	
XY	29	8000 43391	1	Serratura antifurto completa	Anti-left lock assy	Serrure anti-vol compl.	Sicherheitsschloss kpl.	Cerradura compl.	
	31	8000 43928	6	Dado	Nut	Ecrou	Mutter	Tuerca	
XY	34	8000 35531	1	Chiave grezza	Raw key	Clef primitive	Schlüssel	Llave	
XYD	37	8A00 71086	1	Kit compl. poggiapiedi	Compl. footrest Kit	Appui-pied complet	kompl. Fussraster-Kit	Kit compl. apoyapiés	
	38	8000 59433	2	Rullo superiore	Roller	Aiguille	Rolle	Rodillo	
	39	8000 63312	4	Cuscinetto (ø8xø22x7 mm)	Bearing (ø8xø22x7 mm)	Roulement (ø8xø22x7 mm)	Kugellager (ø8xø22x7 mm)	Cojinete (ø8xø22x7 mm)	

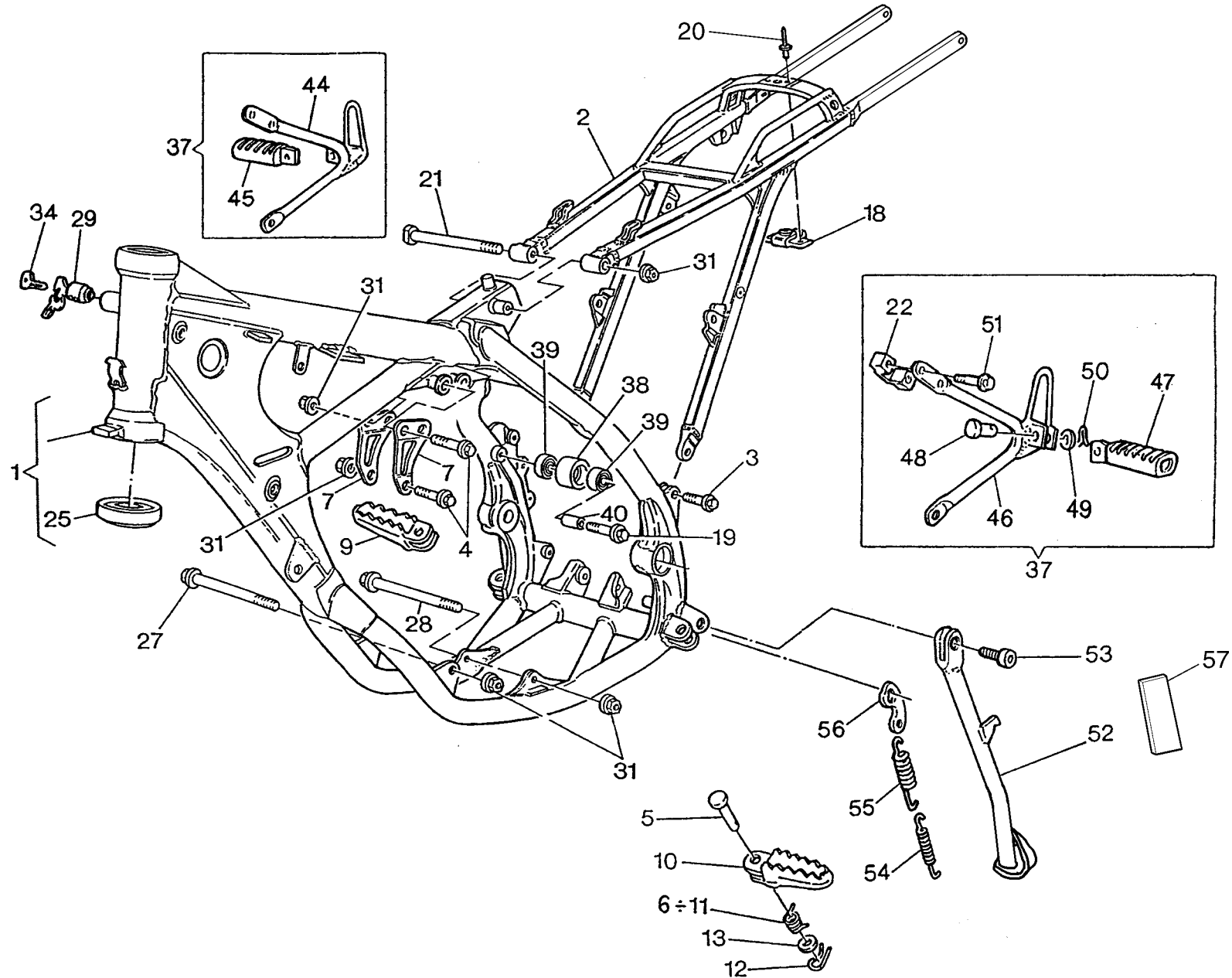

Note Notes Notes Marke Notas	Pos. No. N. Index Pos.	N. Cod. Code No. Nr. Code Code Nr N. Cod.	Q.tà Q.ty Q.te M.ge C.ad	DENOMINAZIONE	NAME	DESIGNATION	BESCHREIBUNG	DENOMINACION	Validità Validity Validité Gültig Validez
	40	8000 59434	2	Distanziale	Spacer	Entretoise	Distanzstück	Separador	
XYD	44	8000 71088	1	Supporto Dx	R.H. support	Support D.	Halterung R.	Soporte der.	
XYD	45	8000 66652	1	Poggiapiedi passeggero Dx.	R.H. foot rest support	Support repose pied D.	R. Fussraster	Posapie der.	
XYD	46	8A00 71087	1	Supporto Sx.	L.H. support	Support G.	Halterung L.	Soporte izq.	
XYD	47	8000 66651	1	Poggiapiedi passeggero Sx.	L.H. foot rest support	Support repose pied G.	L. Fussraster	Posapie izq.	
XYD	48	8000 41459	2	Perno	Pin	Pivot	Bolzen	Perno	
XYD	49	62N1 15504	2	Rosetta	Washer	Rondelle	Scheibe	Arandela	
XYD	50	64N1 20048	2	Copiglia	Split pin	Goupille	Splint	Clavija	
XYD	51	8000 69056	2	Vite (M8x20 mm)	Screw (M8x20 mm)	Vis (M8x20 mm)	Schraube (M8x20 mm)	Tornillo (M8x20 mm)	
XYD	51	8000 62732	2	Vite (M8x25 mm)	Screw (M8x25 mm)	Vis (M8x25 mm)	Schraube (M8x25 mm)	Tornillo (M8x25 mm)	
Y	52	8000 98040	1	Gamba laterale	Side stand	Bequille laterale	Seitenständer	Horquilla lateral	
W	53	8000 97976	1	Vite (M8x25 mm)	Screw (M8x25 mm)	Vis (M8x25 mm)	Schraube (M8x25 mm)	Tornillo (M8x25 mm)	
U	53	8A00 97977	1	Vite (M8x25 mm)	Screw (M8x25 mm)	Vis (M8x25 mm)	Schraube (M8x25 mm)	Tornillo (M8x25 mm)	
Y	54	8000 62676	1	Molla interna	Spring	Ressort	Feder	Resorte	
Y	55	8000 62675	1	Molla esterna	Spring	Ressort	Feder	Resorte	
Y	56	8000 84176	1	Piastrina	Plate	Plaque	Platte	Plaque	
	57	8A00 94356	1	Tampone	Pad	Tampon	Stopfen	Tampón	

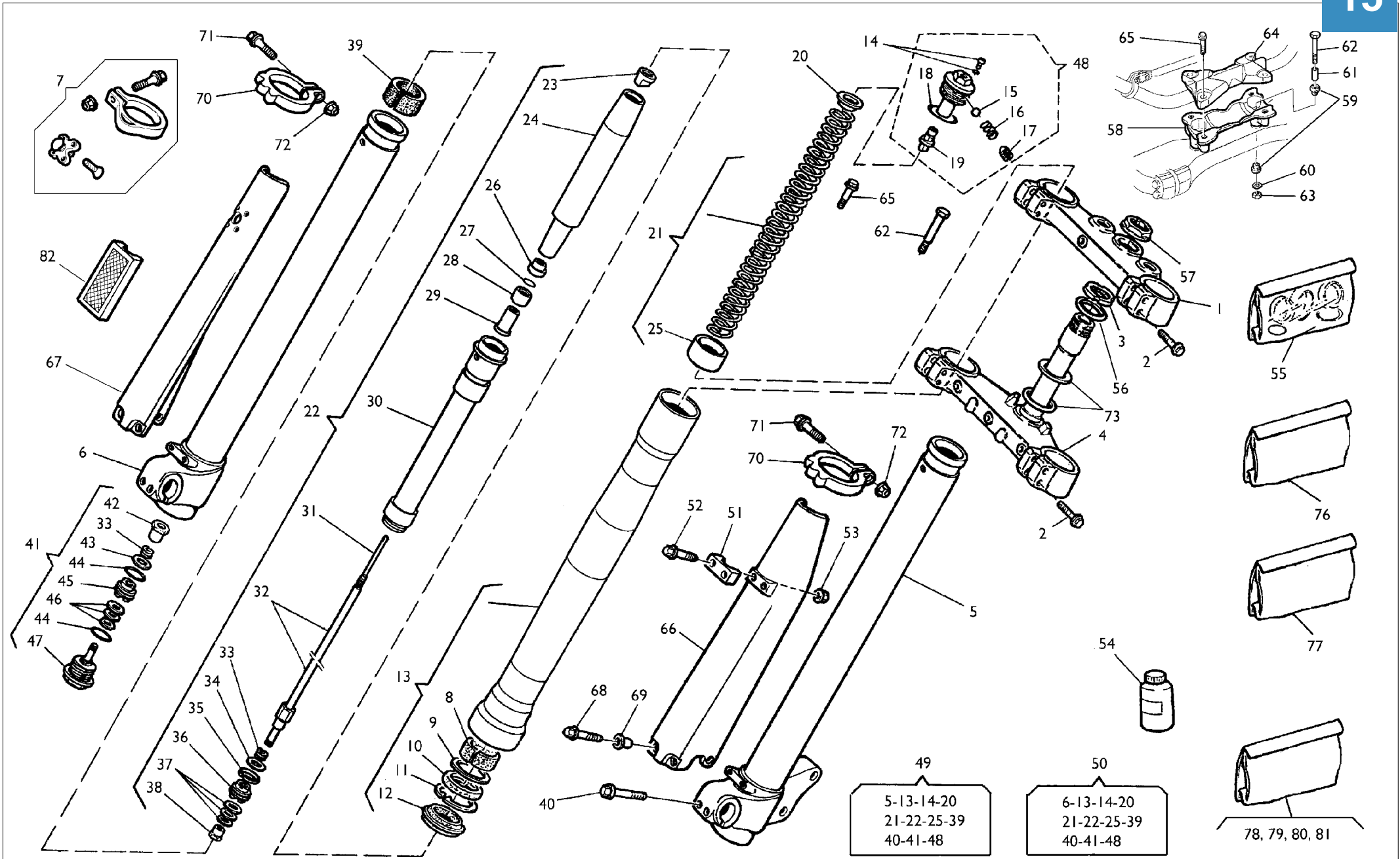



Note Notes Notas	Pos. No. N. Index Pos.	N. Cod. Code No. Nr. Code Code Nr N. Cod.	Q.tà Q.ty Q.te M.ge C.ad	DENOMINAZIONE	NAME	DESIGNATION	BESHREIBUNG	DENOMINACION	Validità Validity Validité Gültig Validez
W	1	8A00 96811	1	Testa di sterzo	Steering head	Tête direction	Lenkkopf	Cabezal de dirección	
C	1	8000 96811	1	Testa di sterzo	Steering head	Tête direction	Lenkkopf	Cabezal de dirección	
	2	8000 62796	8	Vite (M8x40 mm)	Screw (M8x40 mm)	Vis (M8x40 mm)	Schraube (M8x40 mm)	Tornillo (M8x40 mm)	
W	3	8000 83395	1	Ghiera registro cuscinetti	Ring nut	Embout	Nutmutter	Virol	
C	3	8A00 87717	1	Ghiera registro cuscinetti	Ring nut	Embout	Nutmutter	Virol	
W	4	8000 96897	1	Base di sterzo con perno	Steering crown with pin	Socle de direction avec pivot	Gabelbrücke mit Bolzen	Base de dirección con perno	
C	4	8000 96813	1	Base di sterzo con perno	Steering crown with pin	Socle de direction avec pivot	Gabelbrücke mit Bolzen	Base de dirección con perno	
	5	8000 98787	1	Stelo Sx. compl.	L.H. slider assy	Montant G. compl.	Bein, Kpl. L.	Deslizable izrda. compl.	
	6	8000 98786	1	Stelo Dx. compl.	R.H. slider assy	Montant D. compl.	Bein, Kpl. R.	Deslizable der. compl.	
DC	7	8000 A3191	1	Kit gancio partenza	Kit starting hook	Kit crochet pour départ	Abfahrthacken	Gancho por salida	
N	8	(a), (b)	2	Bussola	Bushing	Douille	Buchse	Manguito	
N	9		2	Scodellino	Cup	Cuvette	Teller	Cubeta	
N	10	(a), (c)	2	Anello di tenuta	Seal ring	Bague de retenue	Dichtring	Anillo de retención	
N	11	(c)	2	Anello di fermo	Stop ring	Bague d'arrêt	Haltering	Anillo de retención	
N	12	(a), (c)	2	Raschiapolvere	Dust scraper	Racloir poudre	Pulverabschaber	Rascador de polvo	
	13	8000 91474	2	Portastelo completo	Pipe assy	Groupe tuyau compl.	Rohrgruppe Kpl	Grupo tubo compl.	
N	14		2	Vite	Screw	Vis	Schraube	Tornillo	
N	15		2	Sfera	Ball	Bille	Kugel	Esfera	
N	16		2	Molla per sfera	Spring	Ressort	Feder	Resorte	
N	17		2	Grano filettato	Dowel	Grain	Stift	Pasadòr	
N	18	(a)	2	Anello OR	O-Ring	Bague OR	O-Ring	Anillo OR	
	19	8000 91479	2	Gruppo registro	Adjuster set	Groupe reglage	Reglergruppe	Grupo regulaciòn	
	20	8000 77373	2	Scodellino	Cup	Cuvette	Teller	Cubeta	
W	21	8000 98790	1	Kit molla ( k= 4,0 N/mm)	Spring ( k= 4,0 N/mm)	Ressort ( k= 4,0 N/mm)	Feder ( k= 4,0 N/mm)	Resorte ( k= 4,0 N/mm)	
C	21	8000 91609	1	Kit molla ( k= 4,2 N/mm)	Spring ( k= 4,2 N/mm)	Ressort ( k= 4,2 N/mm)	Feder ( k= 4,2 N/mm)	Resorte ( k= 4,2 N/mm)	
W	22	8000 98552	2	Gruppo pompante compl.	Damping element compl.	Amortissement compl.	Schwingungsdämpfer Kpl.	Bombeadora compl.	
C	22	8000 98792	2	Gruppo pompante compl.	Damping element compl.	Amortissement compl.	Schwingungsdämpfer Kpl.	Bombeadora compl.	
N	23		2	Dado	Nut	Ecrou	Mutter	Tuerca	
N	24		2	Guidamolla	Spring guide	Guide ressort	Federführung	Guia resorte	
N	25		2	Tubetto	Pipe	Tuyau	Rohr	Tubo	
N	26		2	Dado	Nut	Ecrou	Mutter	Tuerca	
N	27		2	Anello SEEGER	SEEGER ring	Anneau SEEGER	SEEGER Ring	Anillo SEEGER	
N	28		2	Tampone di fondo	Pad	Tampon	Stopfen	Tampòn	

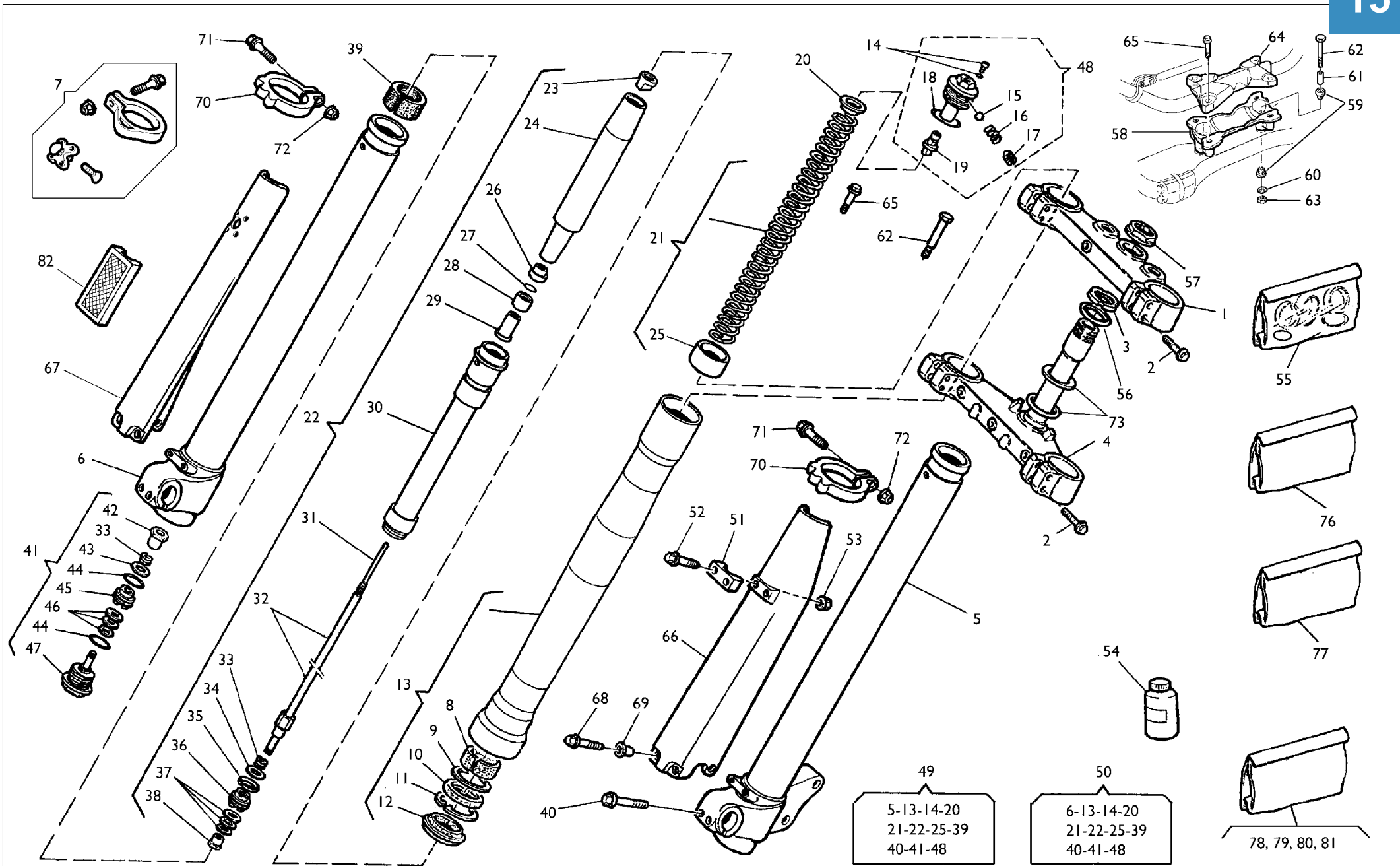

Note Notes Notas	Pos. No. N. Index Pos.	N. Cod. Code No. Nr. Code Code Nr N. Cod.	Q.tà Q.ty Q.te M.ge C.ad	DENOMINAZIONE	NAME	DESIGNATION	BESHREIBUNG	DENOMINACION	Validità Validity Validité Gültig Validez
N	29		2	Distanziale	Spacer	Entretoise	Distanzstück	Separadør	
N	30		2	Custodia	Housung	Cage	Korb	Custodia	
N	31		2	Asta interna	Internal rod	Barre	Stange	Varilla	
N	32		2	Ass. asta	Rod assy	Barre compl.	Stange Kpl	Grupo varilla	
N	33		4	Molla	Spring	Ressort	Feder	Resorte	
N	34	(d)	2	Lamella	Plate	Lamelle	Plättchen	Laminilla	
N	35	(a)	2	Segmento	Circlip	Segment	Colbenring	Segmento	
N	36		2	Pistone estensione	R.H. piston	Piston D.	Kolbe R.	Pistón der.	
N	37	(d)	6	Lamella	Plate	Lamelle	Plättchen	Laminilla	
N	38		2	Dado	Nut	Ecrou	Mutter	Tueca	
N	39	(a), (b)	2	Bussola	Bushing	Douille	Buchse	Manguito	
	40	8000 62729	4	Vite (M6x25 mm)	Screw (M6x25 mm)	Vis (M6x25 mm)	Schraube (M6x25 mm)	Tornillo (M6x25 mm)	
W	41	8000 98806	2	Ass. valvola di fondo	Valve	Soupape	Ventil	Válvula	
C	41	8000 95260	2	Ass. valvola di fondo	Valve	Soupape	Ventil	Válvula	
N	42		2	Dado	Nut	Ecrou	Mutter	Tuerca	
N	43	(d)	2	Lamella	Plate	Lamelle	Plättchen	Laminilla	
N	44	(a)	2	Anello OR	O-Ring	Bague OR	O-Ring	Anillo OR	
N	45		2	Pistone compressione	Piston	Piston	Kolbe	Pistón	
N	46	(d)	6	Lamella	Plate	Lamelle	Plättchen	Laminilla	
N	47		2	Valvola	Valve	Soupape	Ventil	Valvula	
	48	8000 91480	2	Gruppo tappo	Plug assy	Groupe bouchon	Verschlussgruppe Kpl	Grupo tapón	
W	49	8A00 96966	1	Gamba Sx. compl.	L.H. fork leg assy	Fourche complete G.	Telegabel Kpl. L.	Horquilla izrda. compl.	
C	49	8000 96913	1	Gamba Sx. compl.	L.H. fork leg assy	Fourche complete G.	Telegabel Kpl. L.	Horquilla izrda. compl.	
W	50	8A00 96965	1	Gamba Dx. compl.	R.H. fork leg assy	Fourche complete D.	Telegabel Kpl. R.	Horquilla derech. compl.	
C	50	8000 96912	1	Gamba Dx. compl.	R.H. fork leg assy	Fourche complete D.	Telegabel Kpl. R.	Horquilla derech. compl.	
	51	8000 A0633	1	Piastrina	Plate	Plaque	Plättchen	Placa	
	52	8A00 67997	2	Vite	Screw	Vis	Schraube	Tornillo	
	53	8000 61355	2	Dado	Nut	Ecrou	Mutter	Tueca	
R	54	8000 80260	1	Olio forcella	Front fork oil	Huile fourche avant	Öl für die Vordergabel	Aceite horquilladelantera	
	55	8000 91519	1	Gruppo guarnizioni	Gasket set	Groupe garnitures	Dichtungssatz	Grupo juntas	
W	56	8A00 65503	2	Rosetta piana	Washer	Rondelle	Scheibe	Arandela	
C	56	8000 87736	1	Rosetta piana	Washer	Rondelle	Scheibe	Arandela	
W	57	8000 69315	1	Dado	Nut	Ecrou	Mutter	Tuerca	

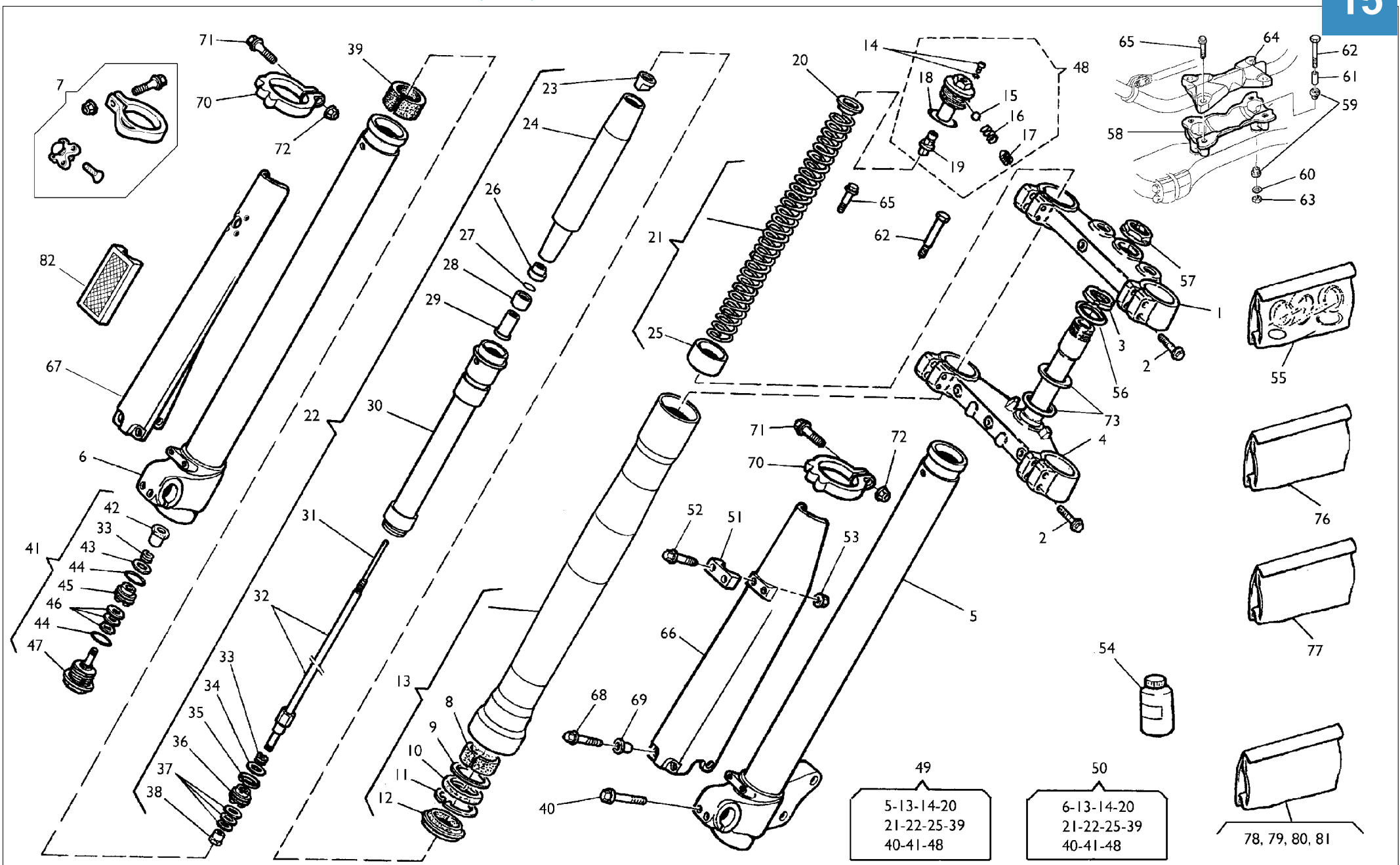

Note Notes Marke Notas	Pos. No. N. Index Pos.	N. Cod. Code No. Nr. Code Code Nr N. Cod.	Q.tà Q.ty Q.te M.ge C.ad	DENOMINAZIONE	NAME	DESIGNATION	BESHREIBUNG	DENOMINACION	Validità Validity Validité Gültig Validez
C	57	8A00 69315	1	Dado	Nut	Ecrou	Mutter	Tuerca	
	58	8000 98237	1	Mozzetto inferiore	Hub	Moyeau	Radnabe	Cbo	
	59	8000 60233	4	Gommino	Rubber pad	Pièce caoutchouc	Gummistück	Junta de goma	
	60	8000 60234	2	Rosetta piana	Washer	Rondelle	Scheibe	Arandela	
	61	8000 53155	2	Distanziale	Spacer	Entretoise	Distanzstück	Separador	
	62	60N1 01219	2	Vite (M10x65 mm)	Screw(M10x65 mm)	Vis(M10x65 mm)	Schraube(M10x65 mm)	Tornillo(M10x65 mm)	
	63	8000 61314	2	Dado	Nut	Ecrou	Mutter	Tuerca	
	64	8000 98118	2	Mozzetto superiore	Hub	Moyeau	Radnabe	Cubo	
	65	8C00 69056	4	Vite (M8x30 mm)	Screw (M8x30 mm)	Vis (M8x30 mm)	Schraube (M8x30 mm)	Tornillo (M8x30 mm)	
	66	80G0 69337	1	Protezione steli Sx.	Guard L.H.	Protection D.	Schutz L.	Protección izq.	
	67	80G0 69338	1	Protezione steli Dx.	Guard R.H.	Protection G.	Schutz R.	Protección der.	
	68	8000 67997	6	Vite	Screw	Vis	Schraube	Tornillo	
	69	8000 69282	6	Bussola	Bush	Douille	Buchse	Manguito	
	70	8000 93283	2	Anello	Ring	Bague	Ring	Anilo	
	71	8B00 66525	2	Vite	Screw	Vis	Schraube	Tornillo	
	72	8000 56443	2	Dado	Nut	Ecrou	Mutter	Tuerca	
C	73	8000 87745	2	Guarnizione di tenuta	Gasket	Garniture	Dichtung	Guarnición	
	76	8000 97750	1	Kit boccole	Bush kit	Kit douille	Buchsekit	Kit manguito	
	77	8000 97749	1	Kit anelli di tenuta	Seal ring kit	Kit bague de retenue	Dichtringkit	Kit anillo de retención	
	78	8000 98782	1	Kit lamelle (0,1 mm)	Plate kit (0,1 mm)	Kit lamelle (0,1 mm)	Plättchenkit (0,1 mm)	Kit Laminilla (0,1 mm)	
	79	8000 98783	1	Kit lamelle (0,2 mm)	Plate kit (0,2 mm)	Kit lamelle (0,2 mm)	Plättchenkit (0,2 mm)	Kit Laminilla (0,2 mm)	
	80	8000 98784	1	Kit lamelle (0,3 mm)	Plate kit (0,3 mm)	Kit lamelle (0,3 mm)	Plättchenkit (0,3 mm)	Kit Laminilla (0,3 mm)	
	81	8000 98785	1	Kit lamelle (0,4 mm)	Plate kit (0,4 mm)	Kit lamelle (0,4 mm)	Plättchenkit (0,4 mm)	Kit Laminilla (0,4 mm)	
	82	8000 73832	2	Catadiottro (AUS, CDN)	Reflector (AUS, CDN)	Catadioptrique (AUS, CDN)	Rückstrahler (AUS, CDN)	Catafaros (AUS, CDN)	
Y	82	80B0 73832	2	Catadiottro (AUS, CDN)	Reflector (AUS, CDN)	Catadioptrique (AUS, CDN)	Rückstrahler (AUS, CDN)	Catafaros (AUS, CDN)	
a				Forniti anche in gruppo pos. 55	Supplied in bag ref. N° 55	Son fournies en unités pos. 55	Sind im Umschlag Bez. Nr 55	Provisto en grupo pos. 55	
b				Forniti anche in gruppo pos. 76	Supplied in bag ref. N° 76	Son fournies en unités pos. 76	Sind im Umschlag Bez. Nr 76	Provisto en grupo pos. 76	
c				Forniti anche in gruppo pos. 77	Supplied in bag ref. N° 77	Son fournies en unités pos. 77	Sind im Umschlag Bez. Nr 77	Provisto en grupo pos. 77	
d				Forniti anche in gruppo pos. 78, 79, 80, 81	Supplied in bag ref. N° 78, 79, 80, 81	Son fournies en unités pos. 78, 79, 80, 81	Sind im Umschlag Bez. Nr 78, 79, 80, 81	Provisto en grupo pos. 78, 79, 80, 81	

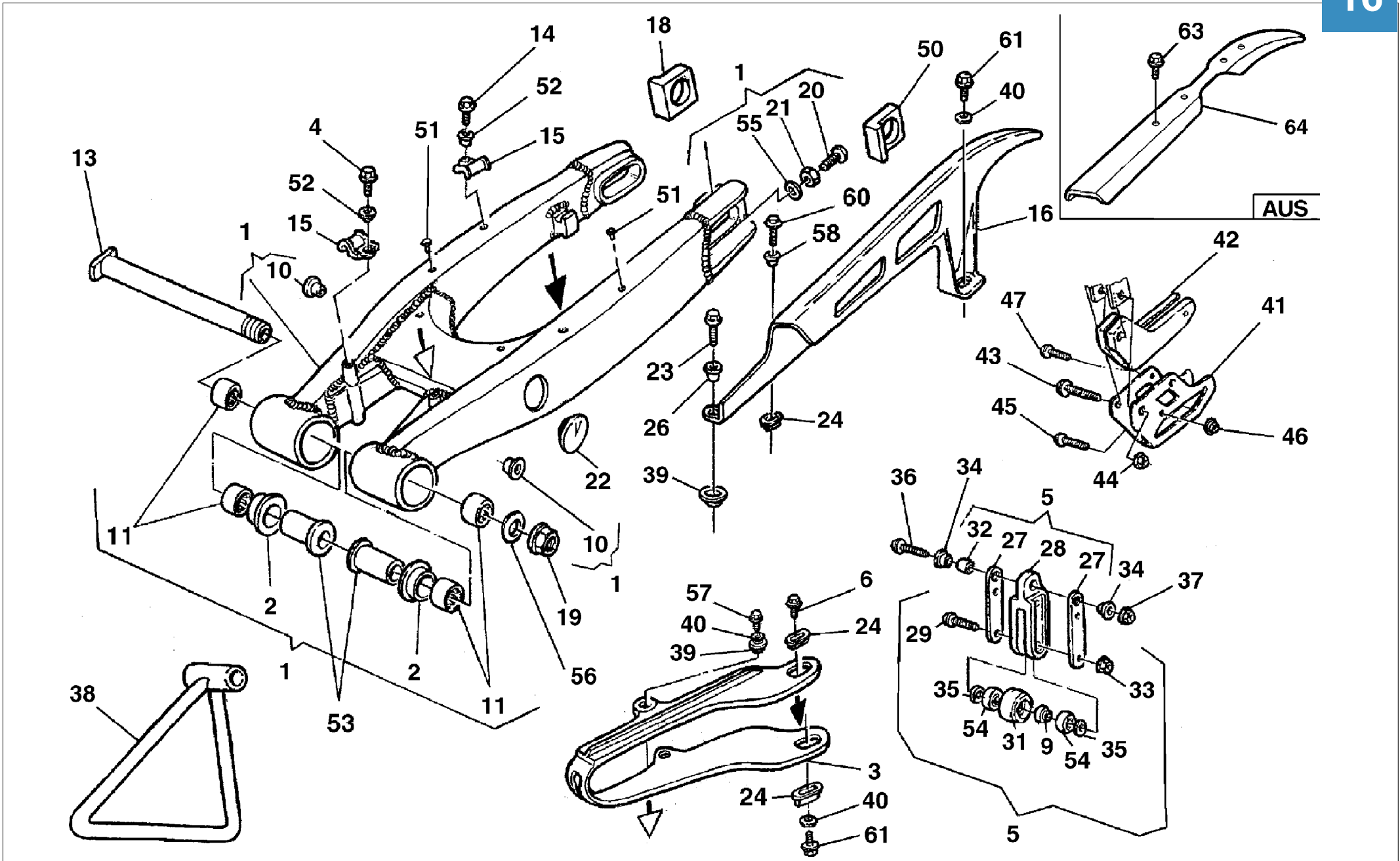



Note Notes Notes Marke Notas	Pos. No. N. Index Pos.	N. Cod. Code No. Nr. Code Code Nr N. Cod.	Q.tà Q.ty Q.te M.ge C.ad	DENOMINAZIONE	NAME	DESIGNATION	BESHREIBUNG	DENOMINACION	Validità Validity Validité Gültig Validez
WU	1	8A00 96959	1	Forcellone completo	Swing arm assy.	Fourche complete	Gabel, Kpl.	Horquilla compl.	
C	1	8000 A2795	1	Forcellone completo	Swing arm assy.	Fourche complete	Gabel, Kpl.	Horquilla compl.	
	2	8000 71622	2	Bussola	Bushing	Douille	Buchse	Manguito	
	3	8000 96960	1	Pattino catena	Chain slider	Glissière	Gleitbahn	Plato cadena	
	4	8000 67997	1	Vite anteriore (M5x12 mm)	Front screw (M5x12 mm)	Vis avant (M5x12 mm)	Vorderschraube (M5x12 mm)	Tornillo delantero (M5x12mm)	
Y	5	8000 72873	1	Ass. guidacatena	Chain guide	Guide chaine	Kettenführung	Guja cadena	
WU	6	8000 67997	1	Vite anteriore (M5x12 mm)	Front screw (M5x12 mm)	Vis avant (M5x12 mm)	Vorderschraube (M5x12 mm)	Tornillo delantero (M5x12mm)	
C	6	8000 20536	1	Vite anteriore (M5x12 mm)	Front screw (M5x12 mm)	Vis avant (M5x12 mm)	Vorderschraube (M5x12 mm)	Tornillo delantero (M5x12mm)	
Y	9	8000 65412	1	Distanziale	Spacer	Entretoise	Distanzstück	Separador	
	10	8A00 87810	2	Bussola Sp.13mm (lato corona)	L.H. bushing (th.13 mm)	Douille G. (épaisseur 13 mm)	Buchse L. (Dicken 13 mm)	Manguito iz. (esp.13 mm)	
	11	8000 76283	4	Gabbia a rullini (ø22xØ28x18 mm)	Needle cage (ø22xØ28x18 mm)	Cage à aiguilles (ø22xØ28x18 mm)	Nadelkaefig (ø22xØ28x18 mm)	Jaula de agujas del cojinete (ø22xØ28x18 mm)	
	13	8000 71620	1	Perno forcellone	Fork pin	Pivot fourche	Gabelbolzen	Perno horquilla	
	14	8000 20536	1	Vite posteriore (Ø4,8x13 mm)	Rear screw (Ø4,8x13 mm)	Vis arriere(Ø4,8x13 mm)	Hinterschraube (Ø4,8x13 mm)	Tornillo trasero (Ø4,8x13 mm)	
	15	80A0 73456	2	Guidacavo	Cable guide	Guide câble	Kabelführung	Guía-cable	
Y	16	80A0 73909	1	Copricatena	Chain guard	Carter de chaine	Kettenkasten	Cubre-cadena	
	18	8000 96944	2	Tendicatena DX	Chain adjuster R.	Tendeur de chaine D.	Kettenspanner R.	Tensor de cadena D.	
	19	8000 71623	1	Dado	Nut	Ecrou	Mutter	.Tuerca	
	20	8C00 61121	2	Vite	Screw	Vis	Schraube	Tornillo	
	21	8000 17810	2	Dado	Nut	Ecrou	Mutter	Tuerca	
	22	80A0 74388	2	Tappo	Plug	Bouchon	Verschluss	Tapón	
Y	23	8A00 67997	1	Vite (M5x16 mm)	Screw (M5x16 mm)	Vis (M5x16 mm)	Schraube (M5x16 mm)	Tornillo (M5x16 mm)	
WU	24	8000 59289	3	Scodellino	Cup	Cuvette	Teller	Cubeta	
C	24	8000 59289	2	Scodellino	Cup	Cuvette	Teller	Cubeta	
Y	26	8A00 69282	2	Bussola	Bushing	Douille	Buchse	Manguito	
Y	27	8000 72875	2	Piastra d'attacco	Plate	Plaque	Platte	Placa	
Y	28	8000 72874	1	Guidacatena	Chain guide	Guide-chaine	Kettenführung	Guía-cadena	
Y	29	8000 62731	2	Vite (M6x45 mm)	Screw (M6x45 mm)	Vis (M6x45 mm)	Schraube (M6x45 mm)	Tornillo (M6x45 mm)	
Y	31	8000 65411	1	Rullo	Roller	Aiguille	Rolle	Rodillo	
Y	32	1515 50601	1	Bussola	Bushing	Douille	Buchse	Manguito	
Y	33	8000 44240	2	Dado	Nut	Ecrou	Mutter	Tuerca	
Y	34	8A00 66661	2	Bussola	Bushing	Douille	Buchse	Manguito	
Y	35	8000 45495	2	Boccola di spallamento	Washer	Rondelle	Scheibe	Arandela	



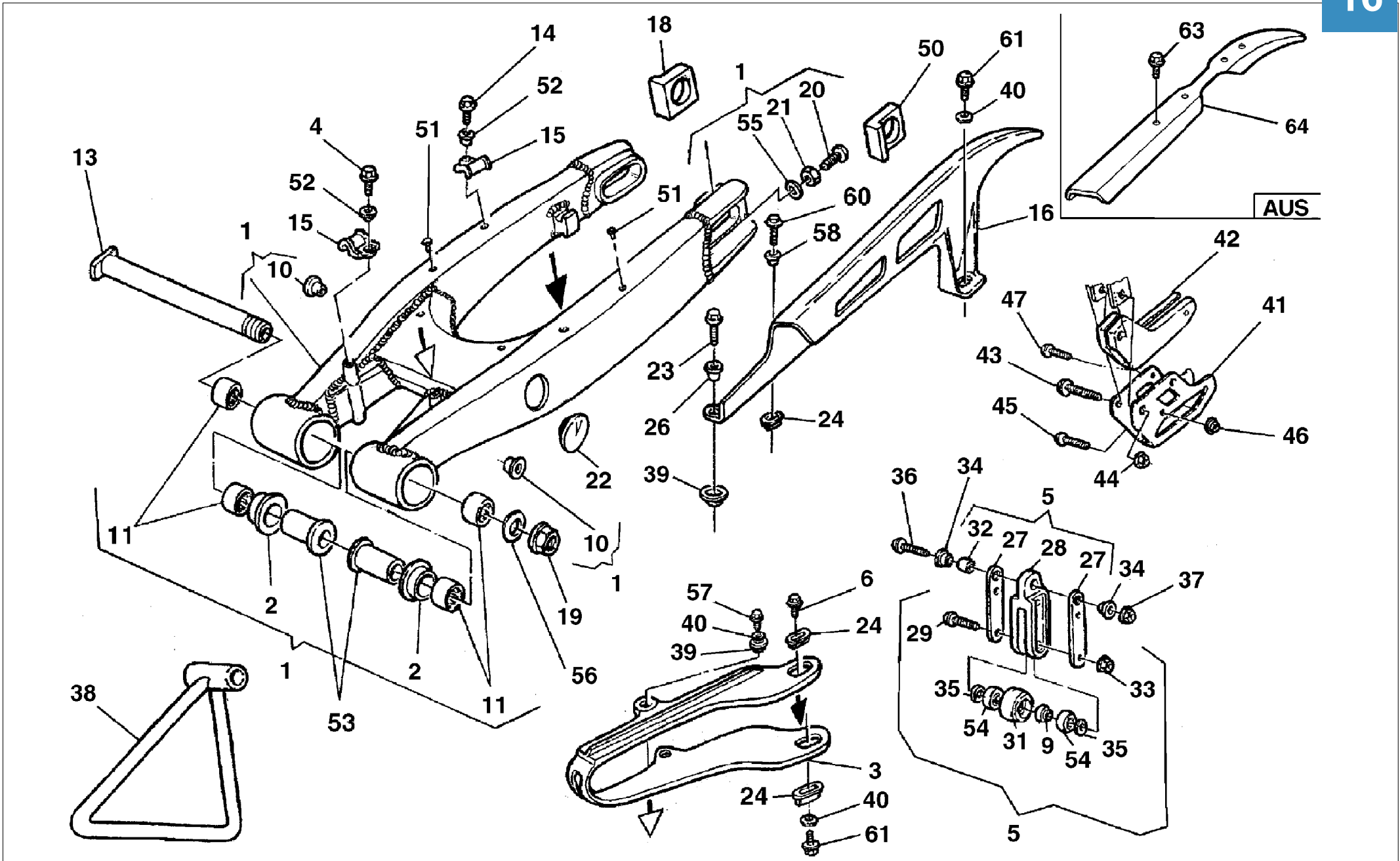

Note Notes Notes Marke Notas	Pos. No. N. Index Pos.	N. Cod. Code No. Nr. Code Code Nr N. Cod.	Q.tà Q.ty Q.te M.ge C.ad	DENOMINAZIONE	NAME	DESIGNATION	BESHREIBUNG	DENOMINACION	Validità Validity Validité Gültig Validez
Y	36	8000 62795	1	Vite	Screw	Vis	Schraube	Tornillo	
Y	37	8000 43928	1	Dado	Nut	Ecrou	Mutter	Tuerca	
CD	38	8000 74016	1	Gamba laterale	Side stand	Bequille lat.	Seitenstander	Horquilla lateral	
	39	8000 75166	4	Scodellino	Cup	Cuvette	Teller	Cubeta	
WU	40	8000 36137	3	Rosetta piana	Washer	Rondelle	Scheibe	Arandela	
C	40	8000 36137	4	Rosetta piana	Washer	Rondelle	Scheibe	Arandela	
C	41	8000 72869	1	Staffa	Bracket	Entier	Buegel	Brida	
C	42	8000 72868	1	Guidacatena	Chain guide	Guidechaine	Kettenführung	Guiacadena	
C	43	8000 62795	1	Vite (M8x50 mm)	Screw (M8x50 mm)	Vis (M8x50 mm)	Schraube (M8x50 mm)	Tornillo (M8x50 mm)	
C	44	8000 43928	1	Dado	Nut	Ecrou	Mutter	Tuerca	
C	45	8000 62731	1	Vite (M6x45 mm)	Screw (M6x45 mm)	Vis (M6x45 mm)	Schraube (M6x45 mm)	Tornillo (M6x45 mm)	
C	46	8000 44240	1	Dado	Nut	Ecrou	Mutter	Tuerca	
C	47	8000 62725	1	Vite (M6x10 mm)	Screw (M6x10 mm)	Vis (M6x10 mm)	Schraube (M6x10 mm)	Tornillo (M6x10 mm)	
	50	8000 96941	1	Tendicatena SX	Chain adjuster L.	Tendeur de chaine G.	Kettenspanne L.	Tensor de cadena I.	
	51	8000 75160	4	Rivetto	Rivet	Rivet	Niet	Remache	
	52	8000 69282	2	Bussola	Bushing	Douille	Buchse	Manguito	
	53	8000 71621	2	Bussola	Bushing	Douille	Buchse	Manguito	
Y	54	8000 63312	2	Cuscinetto (ø8xØ22x7 mm)	Bearing (ø8xØ22x7 mm)	Roulement (ø8xØ22x7 mm)	Lager (ø8xØ22x7 mm)	Cojinete (ø8xØ22x7 mm)	
	55	8000 08536	2	Rosetta piana	Washer	Rondelle	Scheibe	Arandela	
	56	8000 32388	1	Rosetta	Washer	Rondelle	Scheibe	Arandela	
C	57	8000 67997	1	Vite	Screw	Vis	Schraube	Tornillo	
	58	8000 97025	1	Bussola	Bushing	Douille	Buchse	Manguito	
	60	60N1 01059	1	Vite (M5x35 mm)	Screw (M5x35 mm)	Vis (M5x35 mm)	Schraube (M5x35 mm)	Tornillo (M5x35 mm)	
WU	61	8000 20536	3	Vite (Ø4,8x13 mm)	Screw (Ø4,8x13 mm)	Vis (Ø4,8x13 mm)	Schraube (Ø4,8x13 mm)	Tornillo (Ø4,8x13 mm)	
C	61	8000 20536	1	Vite (Ø4,8x13 mm)	Screw (Ø4,8x13 mm)	Vis (Ø4,8x13 mm)	Schraube (Ø4,8x13 mm)	Tornillo (Ø4,8x13 mm)	
	63	8000 81628	4	Vite (AUS)	Screw (AUS)	Vis (AUS)	Schraube (AUS)	Tornillo (AUS)	
	64	8000 A2352	1	Prolunga (AUS)	Guard(AUS)	Carter (AUS)	Kasten (AUS)	Protección (AUS)	

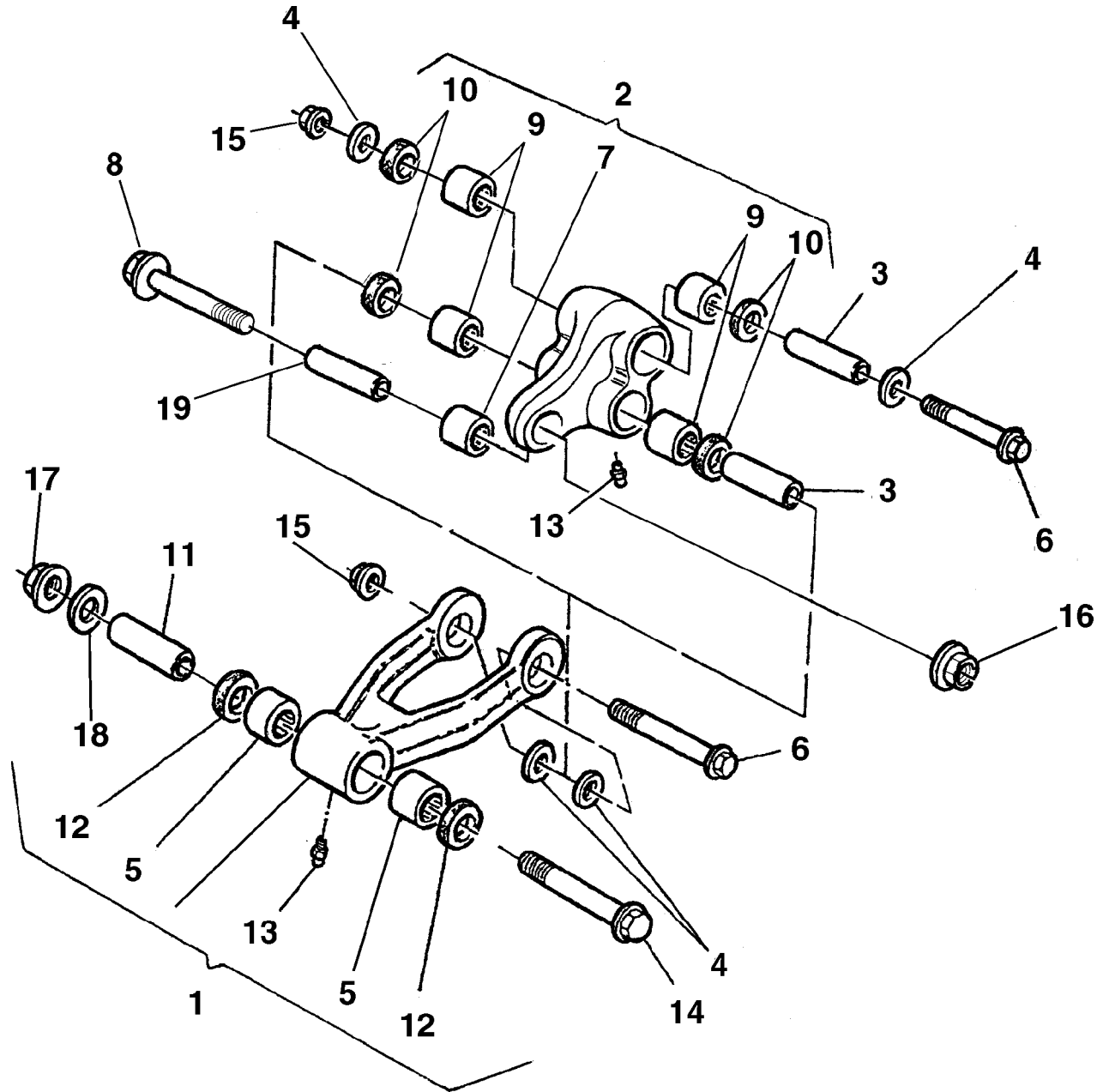

Note Notes Notes Marke Notas	Pos. No. N. Index Pos.	N. Cod. Code No. Nr. Code Code Nr N. Cod.	Q.tà Q.ty Q.te M.ge C.ad	DENOMINAZIONE	NAME	DESIGNATION	BESHREIBUNG	DENOMINACION	Validità Validity Validité Gültig Validez
	1	8000 96922	1	Tirante completo	Tie rod	Tirant	Spannstange	Tirante	
	2	8000 A4429	1	Assieme bilanciare	Rocking lever assy	Balancier compl.	Schwinge Kpl.	Balancines compl.	
	3	8000 86176	2	Spinotto	Gudgeon	Axe	Bolzen	Perno	
	4	8000 86177	4	Distanziale	Spacer	Entretoise	Distanzstück	Separadør	
	5	8000 86136	2	Boccola a rullini Ø28 ø22Sp.16	Rollenbush Ø28 ø22Sp.16	Douille rouleaux Ø28 ø22Sp.16	Rollerbuchse Ø28 ø22Sp.16	Casquillo Ø28 ø22Sp.16	
	6	8000 93124	2	Perno (M12x103 mm)	Pin (M12x103 mm)	Pivot (M12x103 mm)	Bolzen (M12x103 mm)	Perno (M12x103 mm)	
	7	8000 A4430	2	Bussola	Bushing	Douille	Buchse	Manguito	
	8	8D00 62797	1	Perno (M10x47 mm)	Pin (M10x47 mm)	Pivot (M10x47 mm)	Bolzen (M10x47 mm)	Perno (M10x47 mm)	
	9	8000 A4427	4	Boccola a rullini Ø28 ø22Sp.20	Rollenbush Ø28 ø22Sp.20	Douille rouleaux Ø28 ø22Sp.20	Rollerbuchse Ø28 ø22Sp.20	Casquillo Ø28 ø22Sp.20	
	10	8000 86137	4	Anello di tenuta (ø26xØ34x4 mm)	Seal ring (ø26xØ34x4 mm)	Bague d'étanchéité (ø26xØ34x4 mm)	Dichtungsring (ø26xØ34x4 mm)	Anillo de retención (ø26xØ34x4 mm)	
	11	8A00 86176	1	Spinotto	Gudgeon	Axe	Bolzen	Perno	
	12	8000 38521	2	Anello di tenuta (ø22xØ28x4 mm)	Seal ring (ø22xØ28x4 mm)	Bague d'étanchéité (ø22xØ28x4 mm)	Dichtungsring (ø22xØ28x4 mm)	Anillo de retención (ø22xØ28x4 mm)	
	13	8000 01412	2	Ingrassatore	Lubricator	Graisseur	Schmierbüchse	Lubricador	
	14	8C00 86138	1	Perno (M12x81 mm)	Pin (M12x81 mm)	Pivot (M12x81 mm)	Bolzen (M12x81 mm)	Perno (M12x81 mm)	
	15	8000 42023	2	Dado	Nut	Ecrou	Mutter	Tuerca	
	16	8000 42022	1	Dado	Nut	Ecrou	Mutter	Tuerca	
	17	8000 42023	1	Dado	Nut	Ecrou	Mutter	Tuerca	
	18	8000 86140	1	Rosetta per dado	Ring	Bague	Ring	Anillo	
	19	8000 A4431	1	Spinotto	Gudgeon	Axe	Bolzen	Perno	

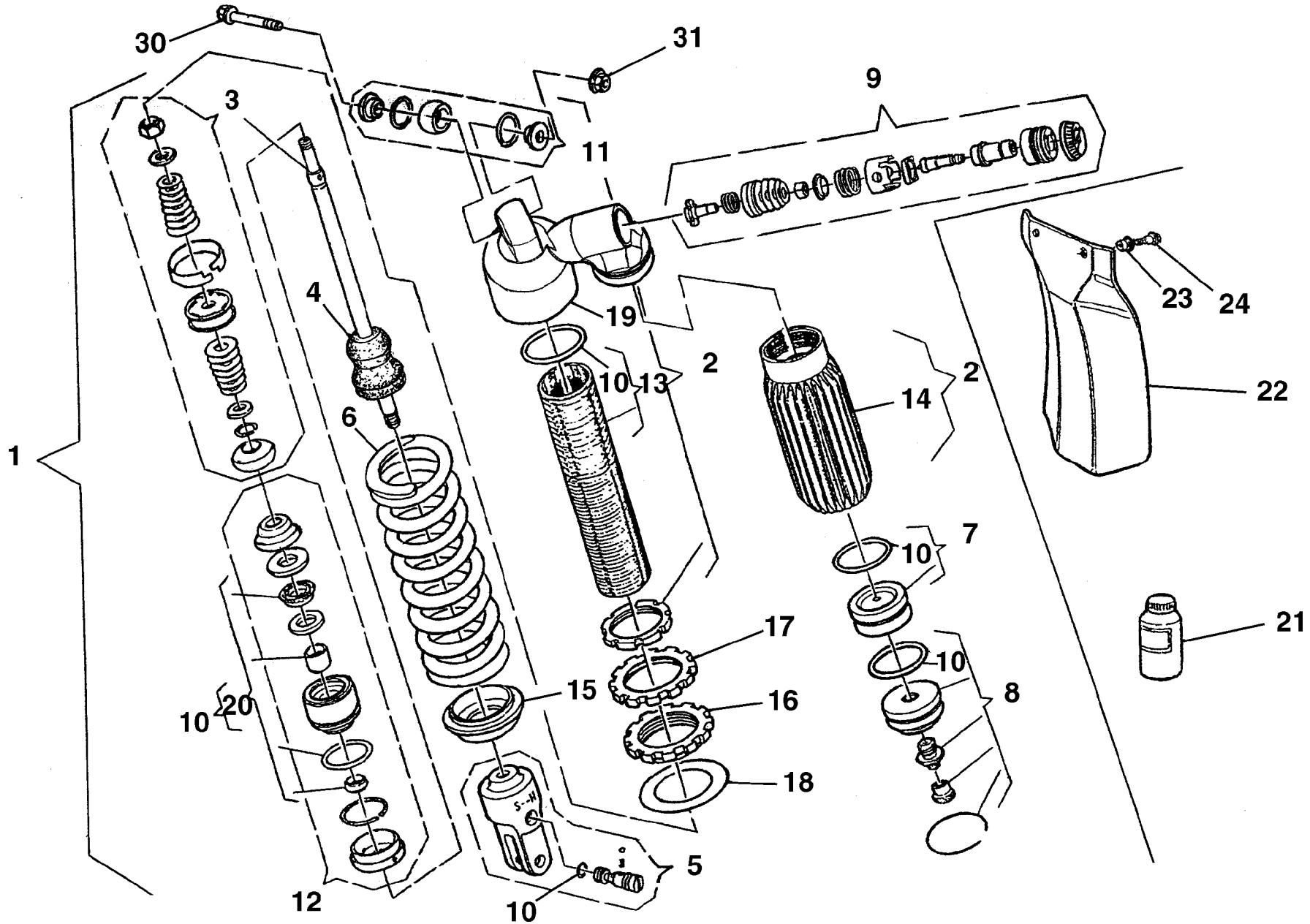

Note Notes Notes Marke Notas	Pos. No. N. Index Pos.	N. Cod. Code No. Nr. Code Code Nr N. Cod.	Q.tà Q.ty Q.te M.ge C.ad	DENOMINAZIONE	NAME	DESIGNATION	BESHREIBUNG	DENOMINACION	Validità Validity Validité Gültig Validez
WU	1	8000 A4559	1	Ammortizzatore completo	Shock-absorber assy.	Ammortisseur compl.	Stossdampfer Kpl.	Amortigüador compl.	
C	1	8000 A4560	1	Ammortizzatore completo	Shock-absorber assy.	Ammortisseur compl.	Stossdampfer Kpl.	Amortigüador compl.	
	2	8000 98500	1	Gruppo corpo	Damper case assy	Groupe corps amortisseur	Stossdämpferkörper Kpl.	Corpo amortigüador compl.	
W	3	8000 98509	1	Gruppo stelo	Rod assy	Groupe tige	Pumpenstückgruppe	Grupo espiga	
C	3	8000 98510	1	Gruppo stelo	Rod assy	Groupe tige	Pumpenstückgruppe	Grupo espiga	
	4	8000 91238	1	Tampone	Pad	Tampon	Stopfen	Tampòn	
	5	8000 98489	1	Gruppo forcella	Fork assy	Groupe fourche	Gabelgruppe Kpl.	Grupo horquilla	
C	6	8000 98568	1	Molla (k=5,0 Kg/mm)	Spring (k=5,0 Kg/mm)	Ressort (k=5,0 Kg/mm)	Feder (k=5,0 Kg/mm)	Resorte (k=5,0 Kg/mm)	
W	6	8000 98569	1	Molla (k=5,2 Kg/mm)	Spring (k=5,2 Kg/mm)	Ressort (k=5,2 Kg/mm)	Feder (k=5,2 Kg/mm)	Resorte (k=5,2 Kg/mm)	
	7	8000 98490	1	Diaframma	Diaphragm	Diaphragme	Biegeplatte	Diafragma	
	8	8000 98491	1	Gruppo serbatoio	Tank assy	Groupe reservoir	Tankgruppe Kpl.	Grupo deposito compl.	
	9	8000 98492	1	Gruppo regolazione	Adjuster set	Groupe réglage	Reglergruppe Kpl.	Grupo regulacion	
	10	8000 98493	1	Gruppo guarnizioni	Gasket set	Groupe garnitures	Dichtungssatz	Grupo juntas	
	11	8000 89089	1	Gruppo snodo	Ball joint assy	Groupe joint a rotule	Kugelgelenkgruppe Kpl.	Grupo articulaciòn esferica	
	12	8000 98494	1	Gruppo guida stelo	Guide rod assy	Groupe guide tige	Pumpenstückführungsgruppe	Grupo guja espiga	
	13	8000 98501	1	Corpo ammortizzatore	Damper case	Corps amortisseur	Stossdämpferkörper	Corpo amortigüador	
	14	8000 98502	1	Serbatoio	Tank	Reservoir	Tank	Deposito	
	15	8000 98496	1	Fondello	Bottom	Fond	Bodenscheibe	Casquilo	
	16	8000 98497	1	Ghiera	Ring nut	Embout	Nutmutter	Virola	
	17	8000 98498	1	Ghiera	Ring nut	Embout	Nutmutter	Virola	
	18	8000 98499	1	Rosetta per molla	Washer	Rondelle	Scheibe	Arandela	
	19	8000 98503	1	Supporto serbatoio	Tank support	Support reservoir	Gastankhalterung	Soporte deposito	
	20	8000 98495	1	Gruppo guarnizioni per stelo	Rod gasket set	Jeu joints pour tige	Dichtungssatz für Pumpenstock	Serie juntas por espiga	
R	21	8000 88231	1	Olio ammortizzatore	Shock-absorber oil	Huile amortisseur	Öl für Stossdampfer	Aceite amortigüador	
	22	80A0 69551	1	Protezione ammortizzatore	Guard	Protection	Schutz	Protección	
	23	8000 69429	2	Bussola	Bushing	Douille	Buchse	Manguito	
	24	8000 62726	2	Vite	Screw	Vis	Schraube	Tornillo	
	30	8A00 62797	1	Vite (M10x50 mm)	Screw (M10x50 mm)	Vis (M10x50 mm)	Schraube (M10x50 mm)	Tornillo (M10x50 mm)	
	31	8000 42022	1	Dado	Nut	Ecrou	Mutter	Tuerca	

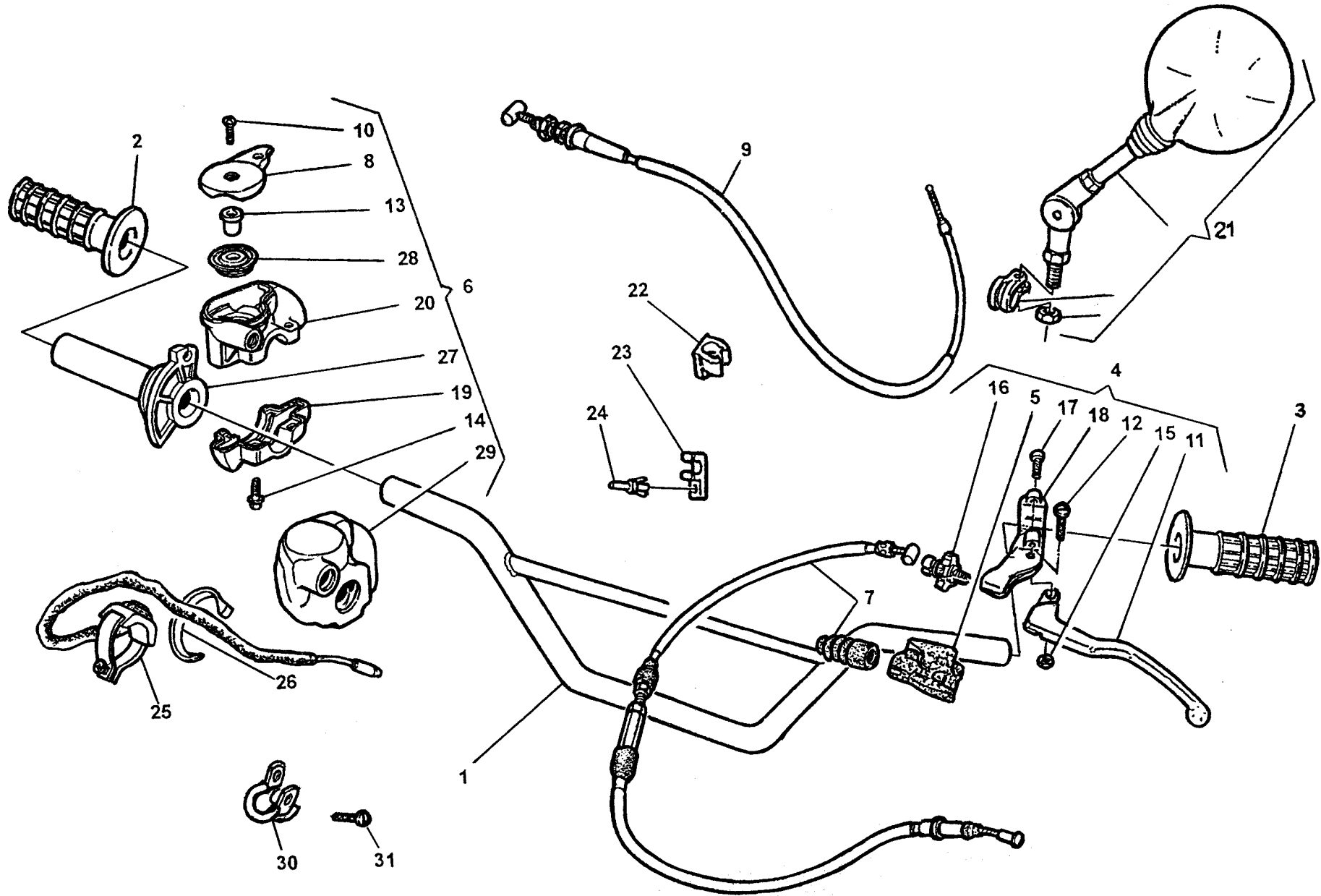



Note Notes Notas	Pos. No. N. Index Pos.	N. Cod. Code No. Nr. Code Code Nr N. Cod.	Q.tà Q.ty Q.te M.ge C.ad	DENOMINAZIONE	NAME	DESIGNATION	BESHREIBUNG	DENOMINACION	Validità Validity Validité Gültig Validez
	1	8000 88280	1	Manubrio (alluminio)	Handlebar (aluminium)	Guidon (aluminium)	Lenker (aluminium)	Manillar (aluminio)	
	2	8000 76688	1	Manopola destra	R.H. grip	Poignée G.	Griff R.	Manopla der.	
	3	8000 76687	1	Manopola sinistra	L.H. grip	Poignée G.	Griff L.	Manopla izq.	
	4	8000 75330	1	Com. frizione completo	Clutch control assy	Commande embrayage complete	Führungssteuerung	Mando embrague compl.	
	5	8000 48917	1	Coprileva	Lever cover	Couvre levier	Hebeldeckel	Cubre-palanca	
	6	8000 88865	1	Comando gas completo	Throttle control cable	Commande gaz compl.	Gasgriff kpl.	Mando acelerador completo	
	7	8000 92817	1	Trasmissione comando frizione	Clutch transm.	Transm. com. embrayage	Führungssteuerung	Trans. mando embrague com.	
	8	8000 93751	1	Coperchietto	Cover	Couvercle	Deckel	Tapa	
	9	8000 92308	1	Trasmissione gas	Throttle cable	Trasm. comm. gaz	Führungsteuerung des Gases	Transm. mando acelerador	
	10	8000 50798	2	Vite	Screw	Vis	Schraube	Tornillo	
	11	8000 77737	1	Leva comando frizione	Clutch lever	Levier embrayage	Kupplungshebel	Palanca mando embrague	
	12	8000 38797	1	Vite	Screw	Vis	Schraube	Tornillo	
	13	8000 93750	1	Bussola	Bush	Douille	Buchse	Manguito	
	14	8000 62728	2	Vite	Screw	Vis	Schraube	Tornillo	
	15	8000 87812	1	Dado	Nut	Ecrou	Mutter	Tuerca	
	16	8000 48916	1	Gruppo registro	Adjuster set	Groupe reglage	Kupplungsreglergruppe	Grupo regul.	
	17	8000 62728	2	Vite	Screw	Vis	Schraube	Tornillo	
	18	8000 70698	1	Cavallotto	U-bolt	Cavalier	Bügelbolzen	Caballate	
	19	8000 93747	1	Supporto inferiore	Lower support	Support inférieur	Untere Halterung	Soporte inferior	
	20	8000 93746	1	Supporto superiore	Upper support	Support supérieur	Obere Halterung	Soporte superior	
XYD	21	8000 65437	2	Specchio retrovisore compl.	Driving mirror	Rétroviseur	Rückspiegel	Espejo retrovisor	
	22	8000 61068	1	Molletta guida trasmissioni	Cable guida	Guide cable	Kabelführung	Guia-cable	
	23	8000 85220	1	Molletta guida trasmissioni	Cable guida	Guide cable	Kabelführung	Guia-cable	
	24	8000 48966	1	Rivetto	Rivet	Rivet	Niet	Remache	
UC	25	8000 96828	1	Pulsante arresto motore	Engine stop button	Poussoir	Knopf	Pulsador	
UC	26	8000 71578	1	Fascetta	Clamp	Collier	Schelle	Banda	
	27	8000 93748	1	Tubo gas	Throttle pipe	Tuyau gaz	Gasrohr	Tubo acelerador	
	28	8000 93749	1	Carrucola	Pulley	Poulie	Führungsrolle	Polea	
	29	8000 93752	1	Gommino coprigas	Rubber cover	Coverture caoutchouc	Gummistück	Goma	
C	30	8000 68690	1	Fascetta	Clamp	Collier	Schelle	Banda	
C	31	8000 62725	1	Vite	Screw	Vis	Schraube	Tornillo	

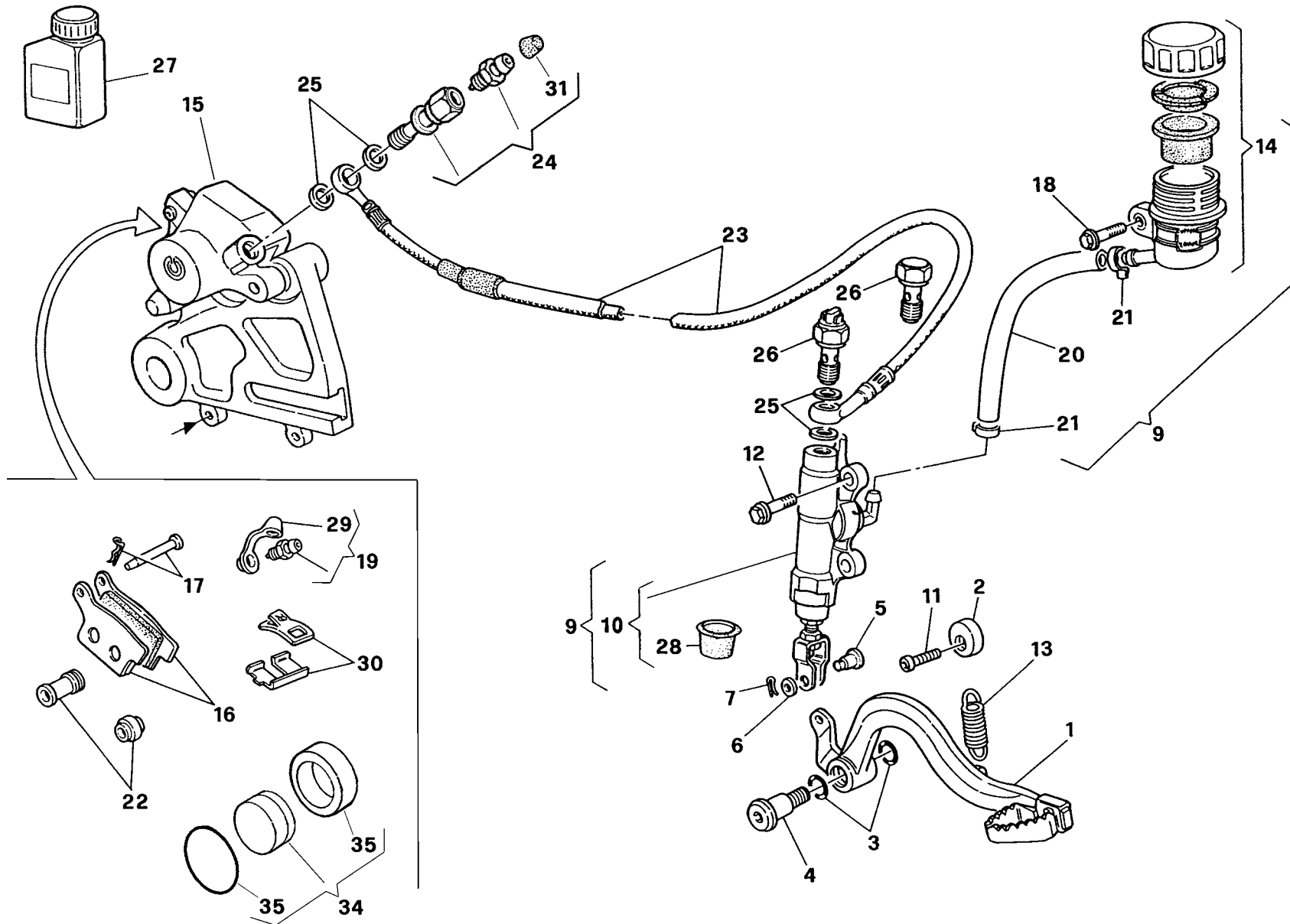

Note Notes Notes Marke Notas	Pos. No. N. Index Pos.	N. Cod. Code No. Nr. Code Code Nr N. Cod.	Q.tà Q.ty Q.te M.ge C.ad	DENOMINAZIONE	NAME	DESIGNATION	BESHREIBUNG	DENOMINACION	Validità Validity Validité Gültig Validez
	1	8A00 73894	1	Pedale comando freno	Brake control pedal	Pedal comm. frein	Bremspedal	Pedal accionamiento freno	
	2	8000 69125	1	Camma	Cam	Came	Nocken	Exéntrico	
	3	8000 22551	2	Anello OR	O-Ring	Bague OR	O-Ring	Anillo OR	
	4	8000 55902	1	Vite	Screw	Vis	Schraube	Tornillo	
	5	8000 70696	1	Perno	Pin	Pivot	Bolzen	Perno	
	6	8000 56377	1	Rosetta	Washer	Rondelle	Scheibe	Arandela	
	7	64N1 20068	1	Copiglia	Split pin	Goupille	Splint	Clavija	
	9	8A00 76026	1	Pompa comando freno compl.	Brake pump assy	Pompe frein complet	Bremspumpe kl.	Bomba freno compl.	
	10	8000 76338	1	Pompa freno	Brake pump	Pompe frein	Bremspumpe	Bomba freno	
	11	8A00 55241	1	Vite	Screw	Vis	Schraube	Tornillo	
	12	8000 62727	2	Vite	Screw	Vis	Schraube	Tornillo	
	13	8A00 55903	1	Molla	Spring	Ressort	Feder	Resorte	
	14	8000 61078	1	Serbatoio olio completo	Oil tank assy	Reservoir huile compl.	Öltank Kpl.	Depósito aceite completo	
WU	15	8000 96939	1	Pinza freno completa	Brake caliper assy	Pince de frein, compl.	Bremszange, Kpl.	Pinza freno compl.	
C	15	8000 A2787	1	Pinza freno completa	Brake caliper assy	Pince de frein, compl.	Bremszange, Kpl.	Pinza freno compl.	
WU	16	8000 79072	1	Coppia pastiglie	Pads pair	Paire plaquettes	Bremsbelagpaar	Pareja pastillas	
C	16	8000 A2790	1	Coppia pastiglie	Pads pair	Paire plaquettes	Bremsbelagpaar	Pareja pastillas	
WU	17	8000 A0933	1	Perno	Pin	Pivot	Bolzen	Perno	
C	17	8000 A2791	1	Perno	Pin	Pivot	Bolzen	Perno	
	18	8000 62725	1	Vite	Screw	Vis	Schraube	Tornillo	
Y	19	8000 A0931	1	Spurgo	Spurgo	Drain	Entleerung	Purga	
	20	8L00 66179	1	Tubazione	Pipe	Tuyau	Rohr	Tubo	
	21	8000 42349	2	Molletta	Spring	Ressort	Feder	Resorte	
	22	8000 79066	1	Cuffia	Boots	Poussiers	haube	Gorro	
WU	23	8000 73893	1	Tubo mandata olio	Pipe	Tuyau	Rohr	Tubo	
C	23	8A00 73893	1	Tubo mandata olio	Pipe	Tuyau	Rohr	Tubo	
WU	24	8000 57155	1	Vite	Screw	Vis	Schraube	Tornillo	
C	24	8000 A3975	1	Vite spurgo	Bleeding screw	Vis vidange	Schraube Entleerung	Tornillo purga	
	25	8000 21480	4	Rosetta	Washer	Rondelle	Scheibe	Arandela	
W	26	8000 94849	1	Interruttore stop posteriore	Rear stop switch	Interrupteur stop	Stopschalter	Interruptor stop	
UC	26	8000 57155	1	Vite	Screw	Vis	Schraube	Tornillo	
	28	8000 79075	1	Cuffia	Boot	Poussier	haube	Gorro	
	29	8000 53259	1	Parapolvere	Boots	Para-poudre	Schutzhaube	Para-polvo	

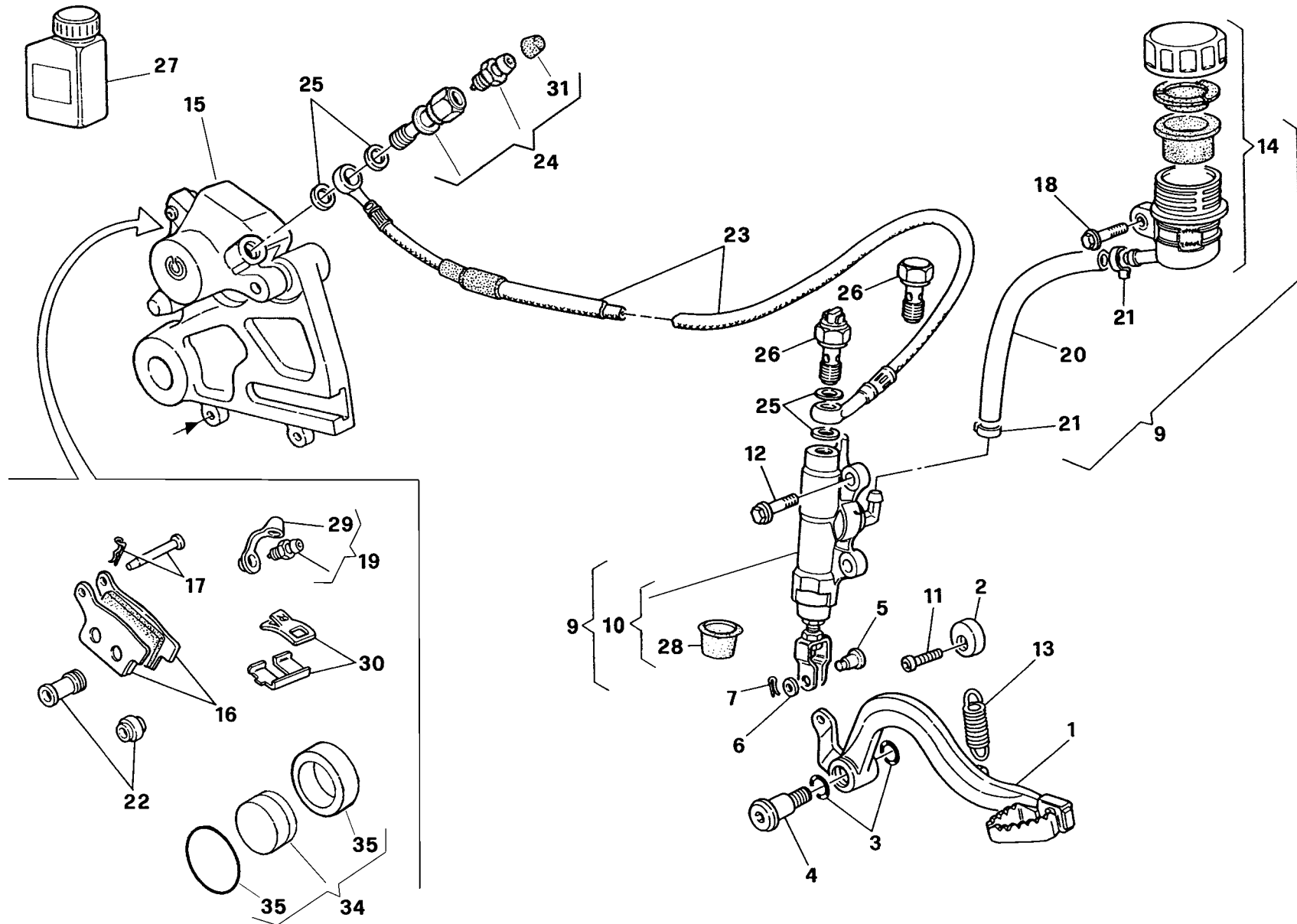

Note Notes Marke Notas	Pos. No. N. Index Pos.	N. Cod. Code No. Nr. Code Code Nr N. Cod.	Q.tà Q.ty Q.te M.ge C.ad	DENOMINAZIONE	NAME	DESIGNATION	BESHREIBUNG	DENOMINACION	Validità Validity Validité Gültig Validez
WU	30	8000 85932	1	Molla-lamierino	Spring-steel clip	Ressort	Feder	Rresorte	
C	30	8000 A2792	1	Molla-lamierino	Spring-steel clip	Ressort	Feder	Rresorte	
WU	34	8000 A0934	1	Pistone	Piston	Piston	Kolben	Pistón	
C	34	8000 A2793	1	Pistone	Piston	Piston	Kolben	Pistón	
C	35	8000 A2794	1	Kit guarnizioni	Seal kit	Kit anneau	Dichtungs Kit	Grupo juntas	

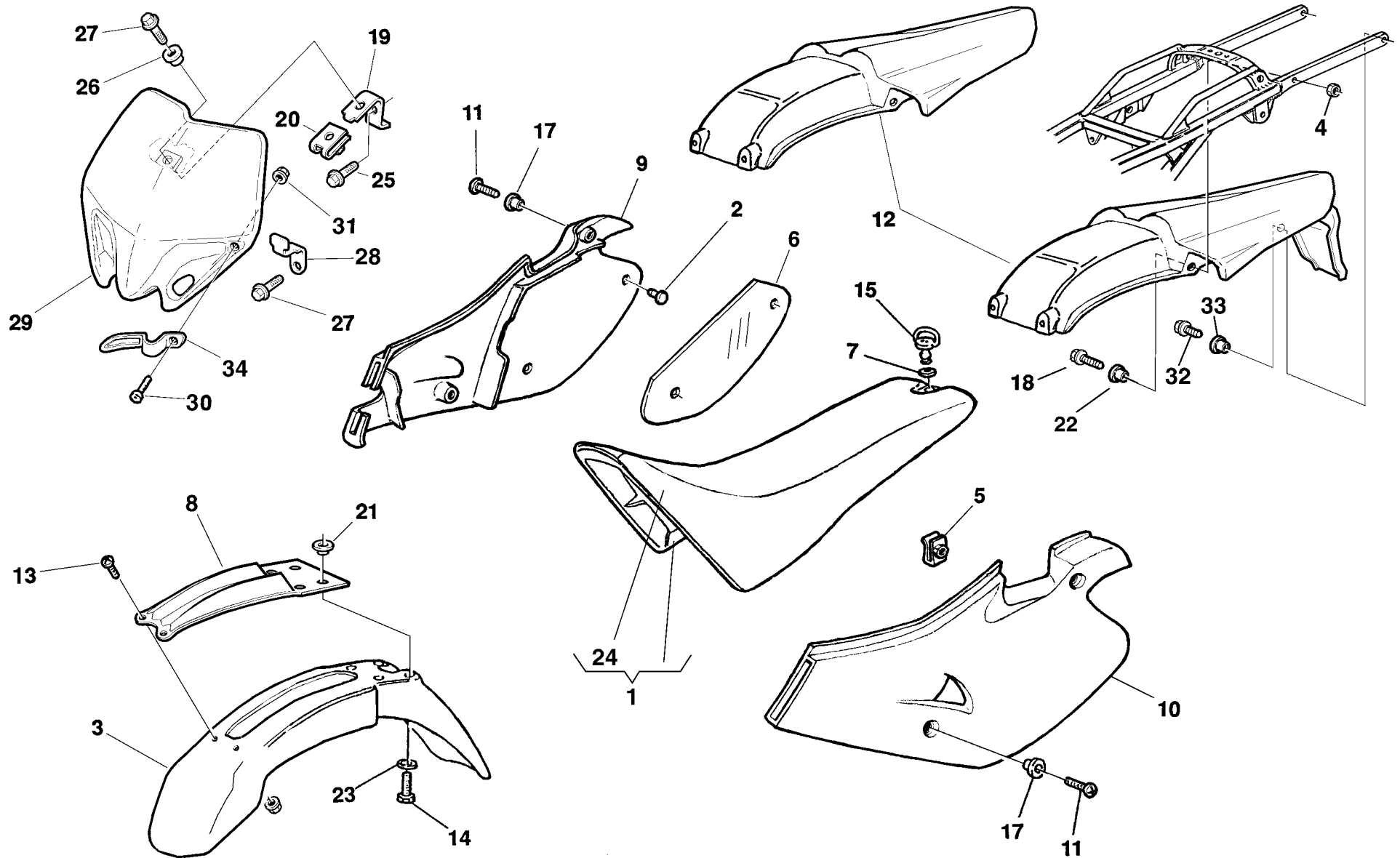

Note Notes Notes Marke Notas	Pos. No. N. Index Pos.	N. Cod. Code No. Nr. Code Code Nr N. Cod.	Q.tà Q.ty Q.te M.ge C.ad	DENOMINAZIONE	NAME	DESIGNATION	BESHREIBUNG	DENOMINACION	Validità Validity Validité Gültig Validez
	1	8000 A0050	1	Sella	Seat	Siège	Sattel	Sillín	
	2	8000 45490	2	Gommino anticalore	Rubber pad	Pièce caoutchouc	Gummistück	Junta de goma	
	3	8A00 A1589	1	Parafango ant.	Front mudguard	Garde-boue avant	Vord. Kotfluegel	Guarda-barros del.	
	4	8000 61313	2	Dado	Nut	Ecrou	Mutter	Tuerca	
	5	8000 46893	2	Dado	Nut	Ecrou	Mutter	Tuerca	
	6	8000 95727	1	Protezione	Guard	Protection	Schutz	Protección	
	7	8000 69149	1	Rosetta elastica	Spring washer	Rondelle élastique	Federscheibe	Arandela elástica	
	8	8000 A4198	1	Rinforzo parafango ant.	Front mudguard reinforcement	Renforcement garde-boue	Vord. Kotfluegel Verstärkung	Refuerzo guardabarros del.	
	9	8000 A4202	1	Pannello destro	R.H. panel	Panneau, D.	Streifen. R.	Panel Der.	
	10	8000 A4203	1	Pannello sinistro	L.H. panel	Panneau, G.	Streifen. L.	Panel Izq.	
	11	8000 62728	4	Vite	Screw	Vis	Schraube	Tornillo	
W	12	8000 A4214	1	Parafango post.	Rear mudguard	Garde-boue arriere	Hint. Kotfluegel	Guarda-barros tras.	
UC	12	8000 A4200	1	Parafango post.	Rear mudguard	Garde-boue arriere	Hint. Kotfluegel	Guarda-barros tras.	
	13	80A0 65535	2	Vite	Screw	Vis	Schraube	Tornillo	
	14	8000 62728	4	Vite	Screw	Vis	Schraube	Tornillo	
	15	8000 69148	1	Perno	Pin	Pivot	Bolzen	Perno	
	16	8000 61355	2	Dado	Nut	Ecrou	Mutter	Tuerca	
	17	8000 69429	4	Boccola	Bushing	Douille	Buchse	Casquillo	
	18	8000 62728	2	Vite (M6x20mm)	Screw (M6x20mm)	Vis (M6x20mm)	Schraube (M6x20mm)	Tornillo (M6x20mm)	
UC	19	8000 A4609	1	Piastrina	Plate	Plaque	Platte	Placa	
UC	20	8000 46893	1	Dado	Nut	Ecrou	Mutter	Tuerca	
	21	8C00 69429	4	Bussola	Bushing	Douille	Buchse	Manguito	
	22	8000 69429	2	Bussola	Bushing	Douille	Buchse	Manguito	
	23	8000 48814	4	Rosetta	Washer	Rondelle	Scheibe	Arandela	
	24	8000 A0051	1	Rivestimento sella	Saddle covering	Revetement selle	Sattelverkleidung	Revestimiento sillin	
UC	25	8E00 67997	1	Vite	Screw	Vis	Schraube	Tornillo	
UC	26	8000 69429	1	Bussola	Bushing	Douille	Buchse	Manguito	
UC	27	8000 62726	3	Vite	Screw	Vis	Schraube	Tornillo	
UC	28	8000 A4607	2	Attacco portanumero	Spacer	Entretoise	Distanzstück	Separadòr	
UC	29	8000 A4216	1	Portanumero	Front number holder	Portnumero	Nummerträger	Portanumero	
UC	30	8000 62730	1	Vite	Screw	Vis	Schraube	Tornillo	
UC	31	8000 44240	1	Dado	Nut	Ecrou	Mutter	Tuerca	
W	32	8000 62726	2	Vite (M6x14mm)	Screw (M6x14mm)	Vis (M6x14mm)	Schraube (M6x14mm)	Tornillo (M6x14mm)	



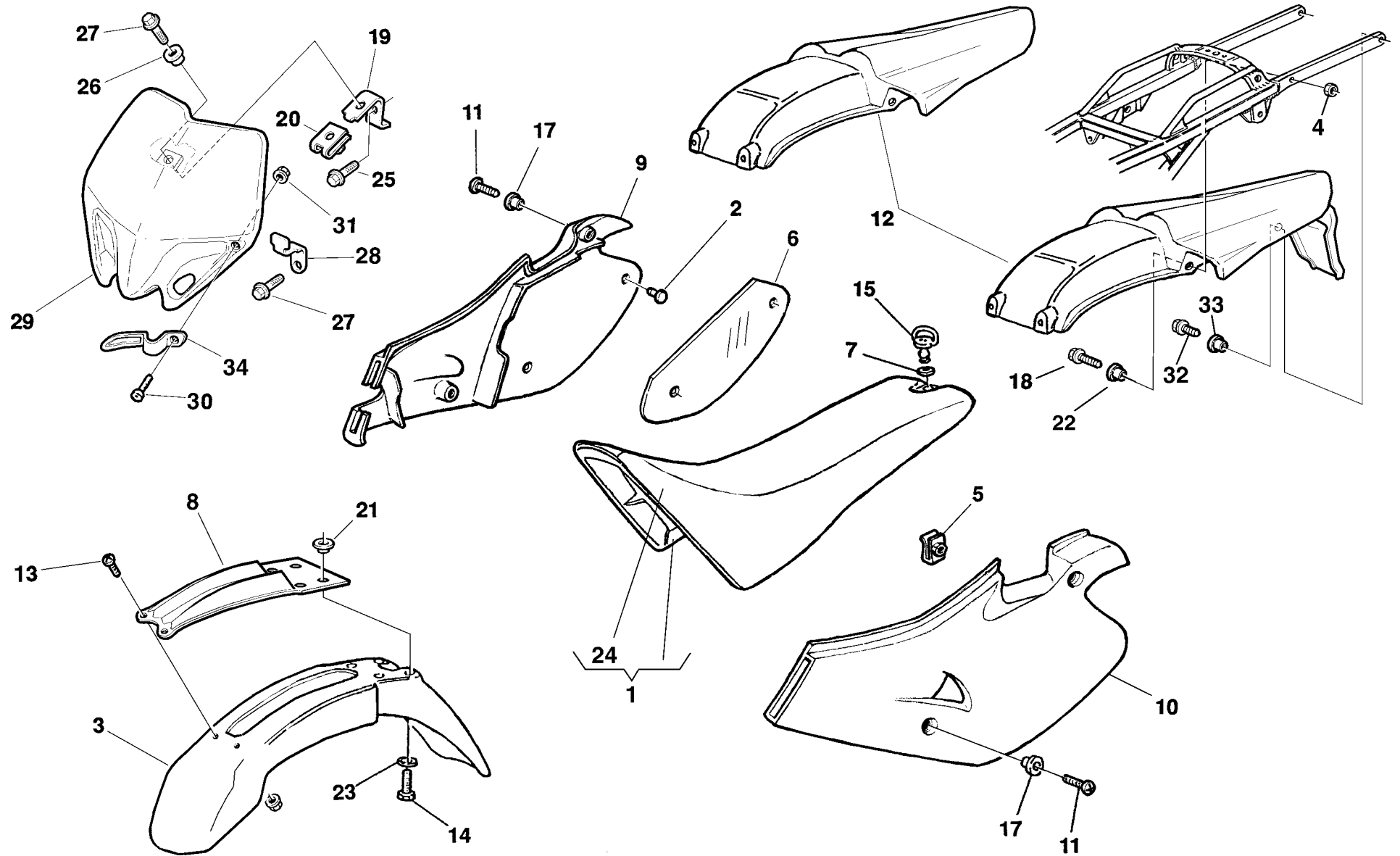



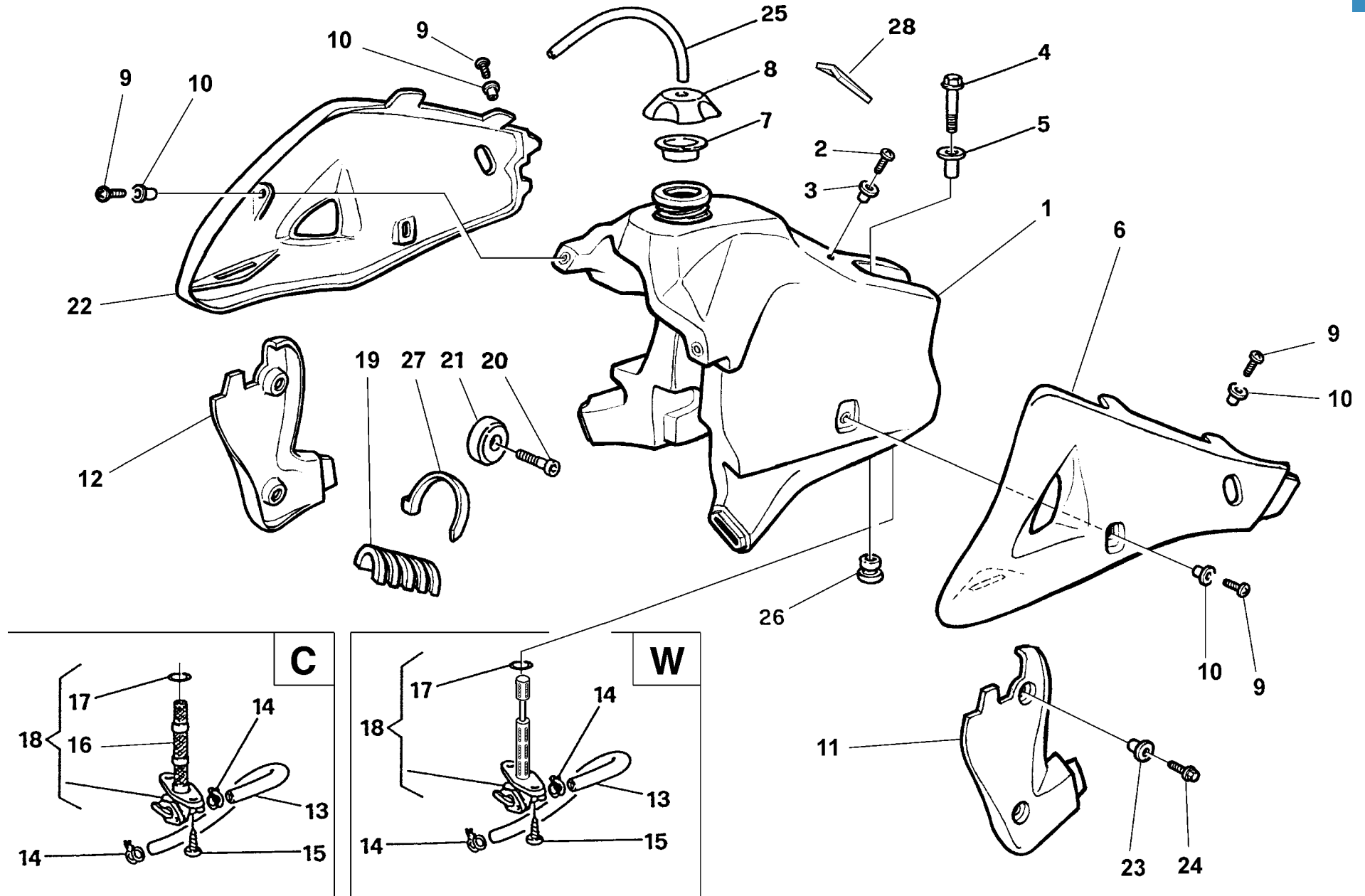

Note Notes Notes Marke Notas	Pos. No. N. Index Pos.	N. Cod. Code No. Nr. Code Code Nr N. Cod.	Q.tà Q.ty Q.te M.ge C.ad	DENOMINAZIONE	NAME	DESIGNATION	BESHREIBUNG	DENOMINACION	Validità Validity Validité Gültig Validez
WC	1	8000 88877	1	Serbatoio carburante (l 8,5)	Fuel tank (l 8,5)	Réservoir à carburant (l 8,5)	Tank (l 8,5)	Depósito gasolina (l 8,5)	
U	1	8000 88862	1	Serbatoio carb. (l 10,2) (U.S.A. - AUS)	Fuel tank (l 10,2) (U.S.A. - AUS)	Réservoir carb. (l 10,2) (U.S.A. - AUS)	Tank (l 10,2) (U.S.A. - AUS)	Dep. gasolina (l 10,2) (U.S.A. - AUS)	
R	1	8000 88862	1	Serbatoio maggiorato (l 10,2)	Fuel lager tank (l 10,2)	Rés. grande capacite (l 10,2)	Überdimensioniert Tank (l 10,2)	Depósito gasolina ampliado (l 10,2)	
	2	60N1 04134	1	Vite	Screw	Vis	Schraube	Tornillo	
	3	8000 66238	1	Distanziale	Spacer	Entretoise	Distanzstück	Separador	
	4	8A00 67545	1	Vite	Screw	Vis	Schraube	Tornillo	
	5	8000 69036	1	Distanziale	Spacer	Entretoise	Distanzstück	Separador	
	6	8AB0 88868	1	Convogliatore SX	L. side panel	Flanc G.	Flanke L.	Lateral l.	
	7	8000 56381	1	Guarnizione	Gasket	Garniture	Dichtung	Junta	
	8	8000 94098	1	Tappo	Plug	Bouchon	Verschluss	Tapón	
	9	8000 36467	8	Vite	Screw	Vis	Schraube	Tornillo	
	10	8000 45495	8	Bussola	Bushing	Douille	Buchse	Manguito	
	11	8000 93883	1	Protezione Sx	L.H. guard	Protection G.	Schutz Linke	Protección izquierda	
	12	8000 93017	1	Protezione Dx	R.H. guard	Protection D.	Schutz Rechte	Protección derecha	
	13	8000 94010	1	Condotto benzina	Pipe	Tuyau	Rohr	Tubo	
	14	80A0 42349	2	Fascetta	Split ring	Anneau ressort	Sprengring	Anillo elástico	
	15	8000 37745	2	Vite	Screw	Vis	Schraube	Tornillo	
C	16	8000 38748	1	Filtro benzina	Fuel filter	Filtre essence	Benzinfilter	Filtro gasolina	
	17	8000 01199	1	Anello OR	O Ring	Bague OR	O-Ring	Anillo OR	
WU	18	8000 A0339	1	Rubinetto completo	Cock assy	Robinet compl.	Kraftstoffahn, Kpl.	Llave de paso compl.	
C	18	8000 43592	1	Rubinetto completo	Cock assy	Robinet compl.	Kraftstoffahn, Kpl.	Llave de paso compl.	
	19	8000 94009	1	Tampone	Pad	Tampon	Stopfen	Tampón	
	20	8000 41240	2	Vite	Screw	Vis	Schraube	Tornillo	
	21	8000 40813	2	Tampone	Pad	Tampon	Stopfen	Tampón	
	22	8AB0 88869	1	Convogliatore DX	R. side panel	Flanc D.	Flanke R.	Lateral D.	
	23	8000 69429	4	Bussola	Bushing	Douille	Buchse	Manguito	
	24	8000 62727	4	Vite	Screw	Vis	Schraube	Tornillo	
	25	8S00 68873	1	Tubetto sfiato (L=380 mm)	Battery breather pipe	Event batterie	Batterieentlüfter	Tubo de purga batería	
	26	8000 69035	1	Gommino	Rubber pad	Pièce caoutchouc	Gummistück	Junta de goma	
	27	8000 50005	1	Fascetta	Split ring	Anneau ressort	Sprengring	Anillo elástico	
W	28	8000 A3119	1	Tampone	Pad	Tampon	Stopfen	Tampón	

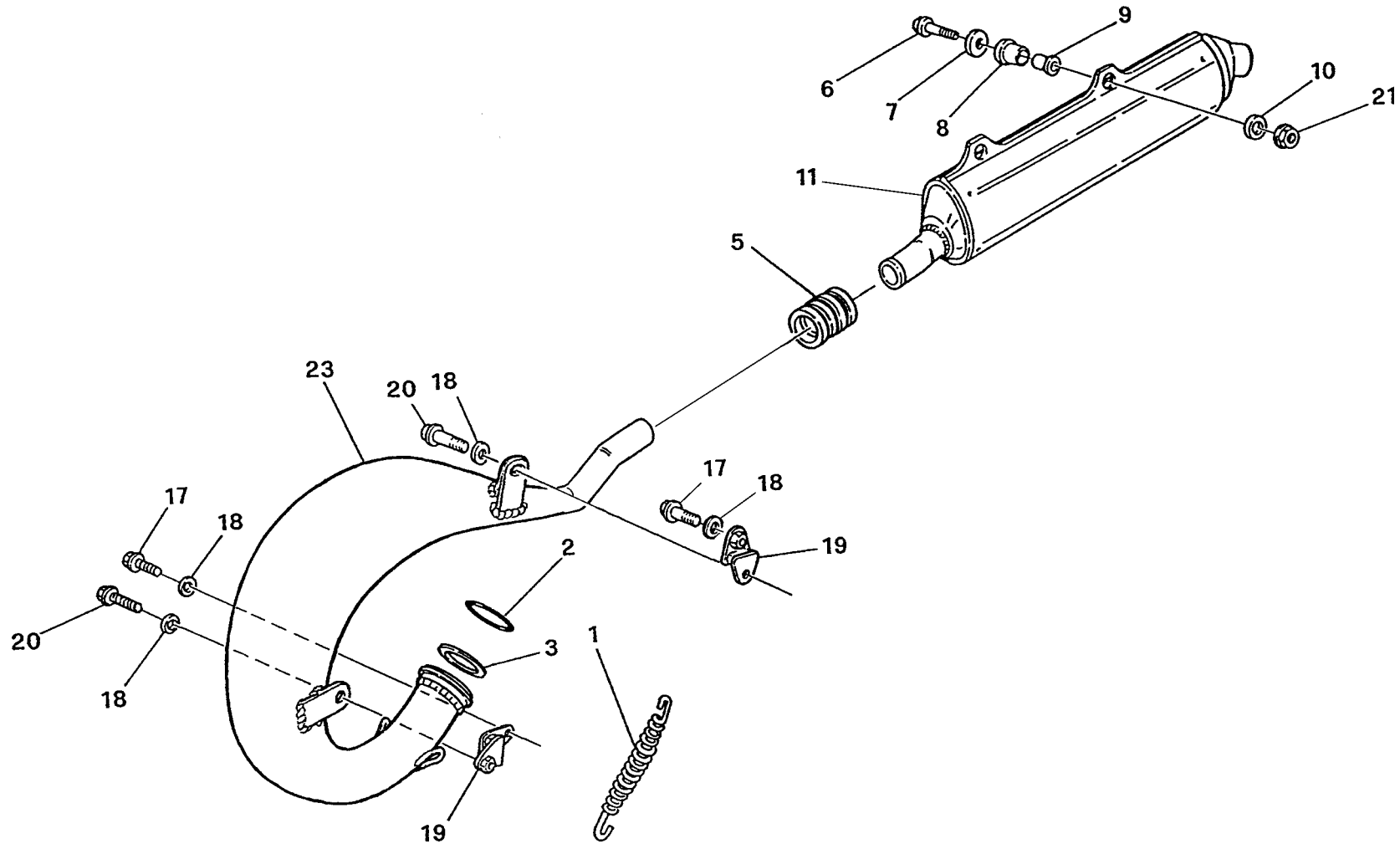

Note Notes Marke Notas	Pos. No. N. Index Pos.	N. Cod. Code No. Nr. Code Code Nr N. Cod.	Q.tà Q.ty Q.te M.ge C.ad	DENOMINAZIONE	NAME	DESIGNATION	BESHREIBUNG	DENOMINACION	Validità Validity Validité Gültig Validez
	1	8000 62341	2	Molla	Spring	Ressort	Feder	Resorte	
	2	8A00 23186	1	Anello OR	O Ring	Bague OR	O-Ring	Anillo OR	
	3	8C00 73541	1	Rosetta	Washer	Rondelle	Scheibe	Arandela	
	5	8000 92788	1	Gommino	Rubber pad	Pièce caoutchouc	Gummistück	Junta de goma	
	6	8000 62730	2	Vite	Screw	Vis	Schraube	Tornillo	
	7	1513 74301	2	Rosetta	Washer	Rondelle	Scheibe	Arandela	
	8	1514 10702	2	Gommino	Rubber pad	Pièce caoutchouc	Gummistück	Junta de goma	
	9	8C00 70379	2	Distanziale	Spacer	Entretoise	Distanzstück	Separador	
	10	1513 41401	2	Gommino	Rubber pad	Pièce caoutchouc	Gummistück	Junta de goma	
W	11	8000 88898	1	Silenziatore completo	Exhaust silencer	Silencieux d'échappement	Schalldämpfer	Silenciador de escape	
C	11	8000 A3118	1	Silenziatore completo	Exhaust silencer	Silencieux d'échappement	Schalldämpfer	Silenciador de escape	
U	11	8000 A0490	1	Silenziatore completo	Exhaust silencer	Silencieux d'échappement	Schalldämpfer	Silenciador de escape	
	17	8000 62726	2	Vite	Screw	Vis	Schraube	Tornillo	
	18	8000 45499	4	Rosetta piana	Washer	Rondelle	Scheibe	Arandola	
	19	8000 69113	2	Antivibrante	Silent-block	Antivibration	Schwingungsdämpfer	Anti-vibrador	
	20	8000 62725	2	Vite	Screw	Vis	Schraube	Tornillo	
	21	8000 44240	2	Dado	Nut	Ecrou	Mutter	Tuerca	
W	23	8000 A0099	1	Tubo di scarico	Exhaust pipe	Tuyau d'échapp.	Auspuffrohr	Tubo de escape	
C	23	8000 A2773	1	Tubo di scarico	Exhaust pipe	Tuyau d'échapp.	Auspuffrohr	Tubo de escape	
U	23	8000 A0099	1	Tubo di scarico	Exhaust pipe	Tuyau d'échapp.	Auspuffrohr	Tubo de escape	

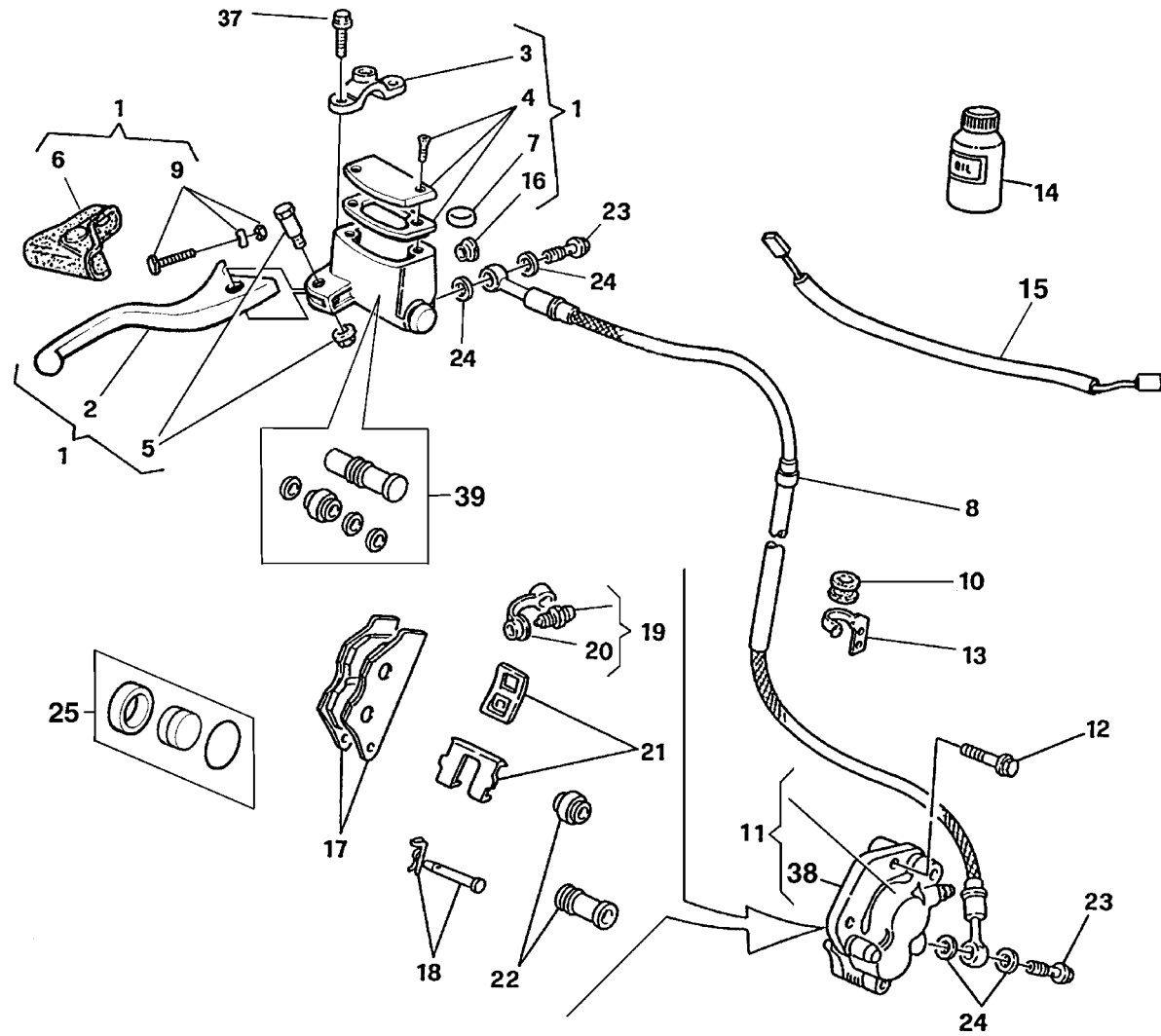



Note Notes Notes Marke Notas	Pos. No. N. Index Pos.	N. Cod. Code No. Nr. Code Code Nr N. Cod.	Q.tà Q.ty Q.te M.ge C.ad	DENOMINAZIONE	NAME	DESIGNATION	BESHREIBUNG	DENOMINACION	Validità Validity Validité Gültig Validez
W	1	8000 A4552	1	Pompa comando freno ant.	Brake pump	Pompe frein	Bremspumpe	Bomba freno	
CU	1	8000 A4495	1	Pompa comando freno ant.	Brake pump	Pompe frein	Bremspumpe	Bomba freno	
CE	1	8000 93109	1	Pompa comando freno ant. (&)	Brake pump (&)	Pompe frein (&)	Bremspumpe (&)	Bomba freno (&)	
	2	8000 A4564	1	Leva	Lever	Levier	Hebel	Palanca	
CE	2	8000 94124	1	Leva (&)	Lever (&)	Levier (&)	Hebel (&)	Palanca (&)	
W	3	8000 A4568	1	Cavallotto	U-bolt	Cavalier	Bügelbolzen	Caballete	
UC	3	8000 A4565	1	Cavallotto	U-bolt	Cavalier	Bügelbolzen	Caballete	
CE	3	8000 94125	1	Cavallotto (&)	U-bolt (&)	Cavalier (&)	Bügelbolzen (&)	Caballete (&)	
	4	8000 94126	1	Kit tappo	Plug kit	Bouchon kit	Verschluss Gruppe	Kit tapón	
	5	8000 94127	1	Perno	Pin	Pivot	Bolzen	Perno	
	6	8000 94128	1	Cappuccio	Cap	Capuchon	Kappe	Capuchon	
	7	8000 79099	1	Antiemulsione	Antiemulsion	Antiemulsion	Eulsionwidriger	Antiemulsion	
WU	8	8000 A0600	1	Tubo mandata olio	Pipe	Tuyau	Rohr	Tubo	
C	8	8000 93036	1	Tubo mandata olio	Pipe	Tuyau	Rohr	Tubo	
W	9	8000 A4569	1	Regolazione	Adjuster	Registre	Regler	Regulizador	
UC	9	8000 A4566	1	Regolazione	Adjuster	Registre	Regler	Regulizador	
CE	9	8000 A0927	1	Regolazione (&)	Adjuster (&)	Registre (&)	Regler (&)	Regulizador (&)	
UC	10	8000 71806	1	Occhiello passatubo	Fairlead	Passe câble	Kabelführung	Prensa cable	
	11	8000 99674	1	Pinza freno	Brake caliper	Etrier frein	Bremssattel	Pinza	
	12	8000 62733	2	Vite	Screw	Vis	Schraube	Tornillo	
UC	13	8000 72022	1	Piastrina di ritegno	Plate	Plaque	Platte	Placa	
R	14	8000 71445	1	Olio freni	Brake oil	Huile frein	Bremsol	Aceite freni	
W	15	8000 A0929	1	Interruttore stop	Stop switch	Interrupteur stop	Stopschalter	Interruptor stop	
	16	8000 49654	1	Oblò	Inspection plug	Capuchon de inspection	Stopfen	Portilla	
	17	8000 96934	1	Coppia pastiglie	Pads pair	Paire plaquettes	Bremsbelagpaar	Pareja pastillas	
	18	8000 A0932	1	Perno	Pin	Pivot	Bolzen	Perno	
	19	8000 A0931	1	Spurgo	Spurgo	Drain	Entleerung	Purga	
	20	8000 53259	1	Parapolvere	Boots	Para-poudre	Schutzhaube	Para-polvo	
	21	8000 79065	1	Molla-lamierino	Spring-steel clip	Ressort	Feder	Rresorte	
	22	8000 79066	1	Cuffie	Boots	Poussiers	haube	Gorro	
	23	8000 57155	2	Vite	Screw	Vis	Schraube	Tornillo	
	24	8000 21480	4	Rosetta	Washer	Rondell'e	Scheibe	Arandela	
	25	8000 A0930	1	Pistone	Piston	Piston	Kolben	Pistón	

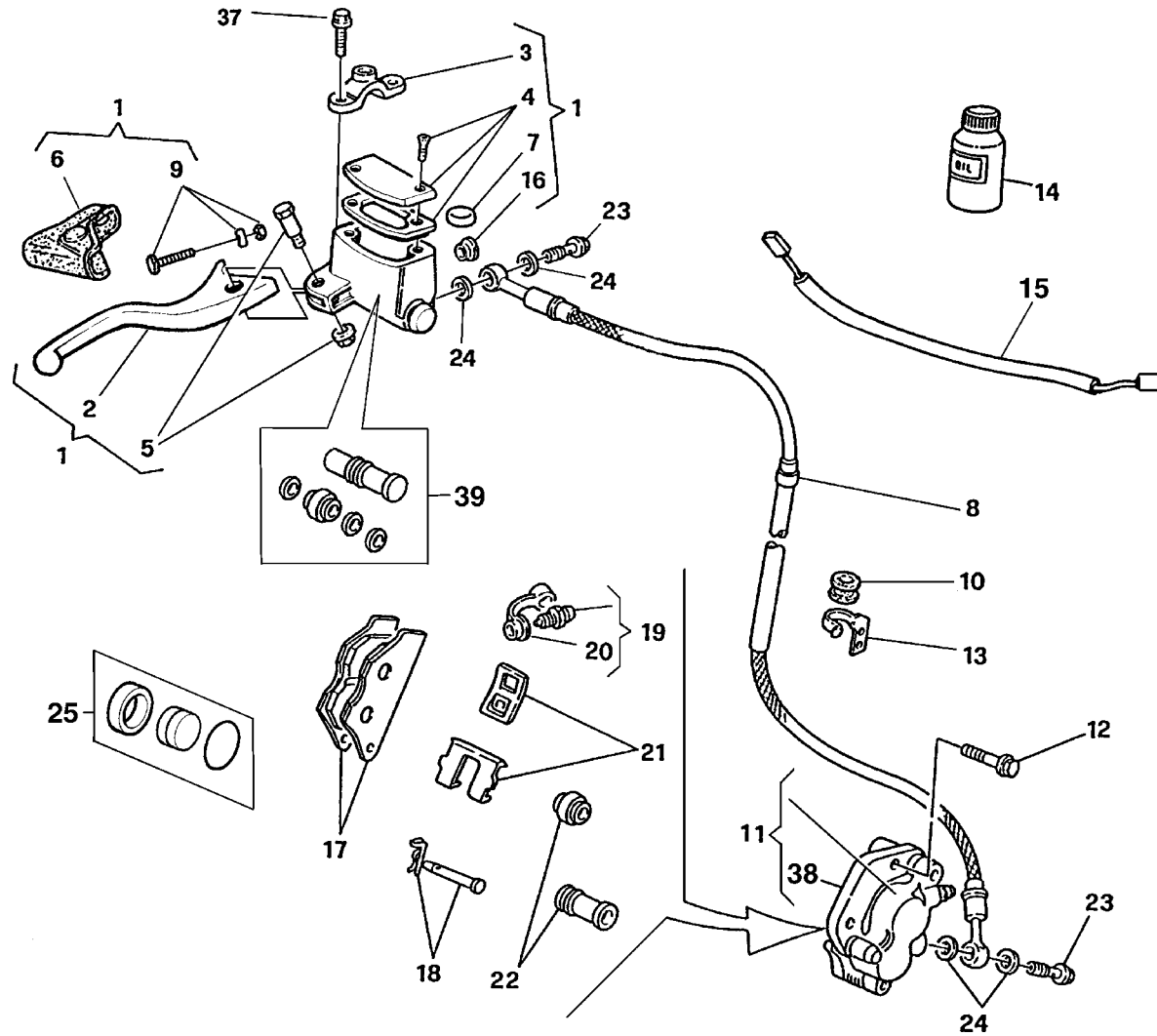



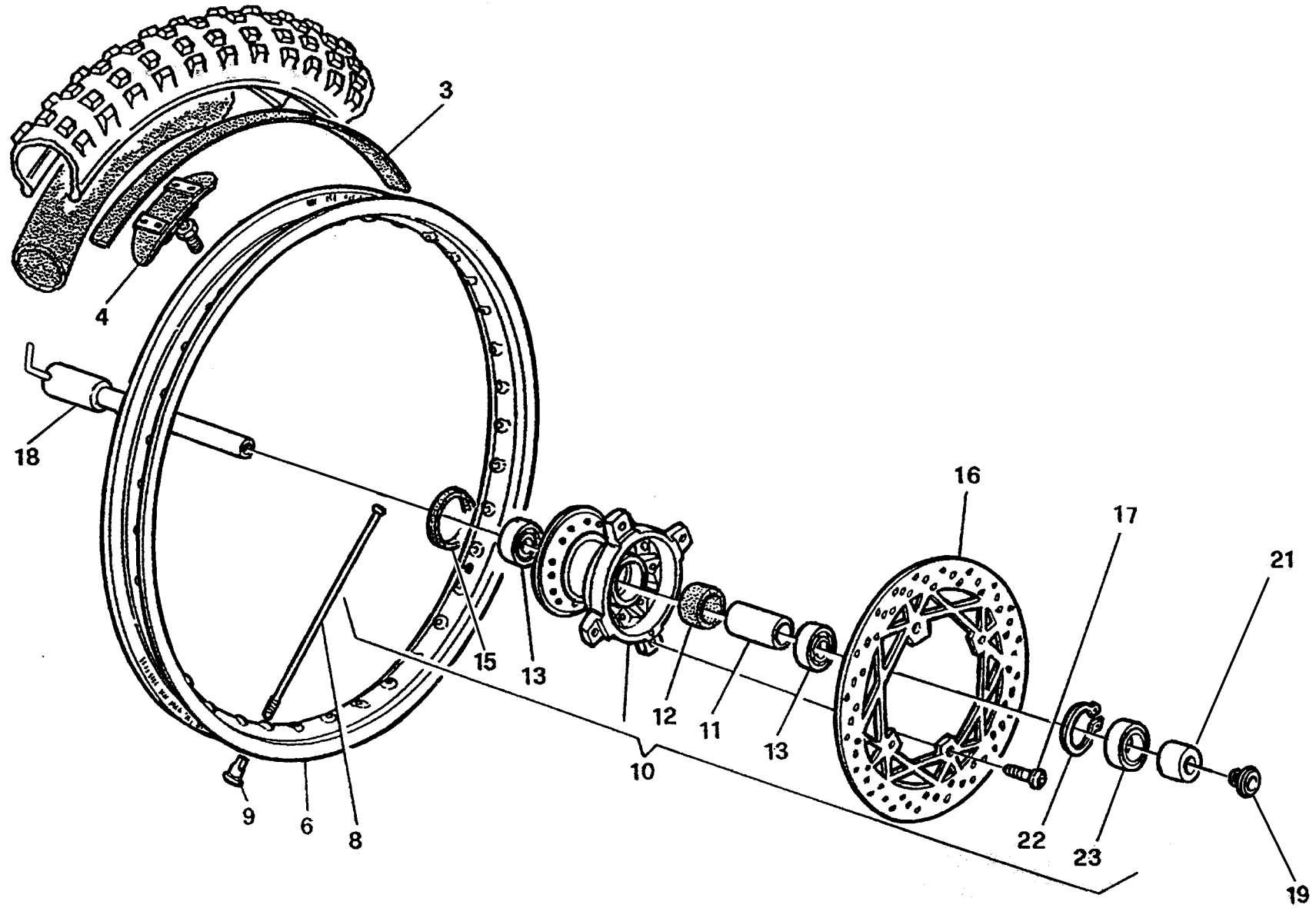

Note Notes Notes Marke Notas	Pos. No. N. Index Pos.	N. Cod. Code No. Nr. Code Code Nr N. Cod.	Q.tà Q.ty Q.te M.ge C.ad	DENOMINAZIONE	NAME	DESIGNATION	BESHREIBUNG	DENOMINACION	Validità Validity Validité Gültig Validez
	3	8000 13346	1	Fascia copriraggi	Rim strip	Bande	Band	Banda	
	4	8000 49036	1	Staffa fermacopertone	Bracket	Etrier	Buegel	Brida	
	6	8A00 53504	1	Cerchio (1,6x21")	Rim (1,6x21")	Jante (1,6x21")	Felge (1,6x21")	Llanta (1,6x21")	
	8	8000 A0080	36	Raggio	Spoke	Bras	Speiche	Radio	
	9	8000 A0081	36	Nipplo	Nipple	Nipple	Nippel	Nipple	
	10	8000 96838	1	Mozzo completo	Hub assy	Moyeau compl.	Radnabe, Kpl.	Cubo compl.	
	11	8000 96928	1	Distanziale	Spacer	Entretoise	Distanzstück	Separador	
	12	8000 92797	1	Portadistanziale	Spacer holder	Porte-entretoise	Abstandstückhalter	Porta-distancial	
	13	8000 84938	2	Cuscinetto a sfere Ø42 ø25 Sp.9	Ball bearing Ø42 ø25 Sp.9	Roulement à billes Ø42 ø25 Sp.9	Kugellager Ø42 ø25 Sp.9	Cojinete de bolas Ø42 ø25 Sp.9	
	15	8A00 92986	1	Anello di tenuta Ø50 ø28 Sp.5	Seal ring Ø50 ø28 Sp.5	Bague d'étanchéité Ø50 ø28 Sp.5	Dichtungsring Ø50 ø28 Sp.5	Anillo de retención Ø50 ø28 Sp.5	
	16	8000 99632	1	Disco freno (Ø260 mm)	Brake disc (Ø260 mm)	Disque frein (Ø260 mm)	Bremsscheibe (Ø260 mm)	Disco freno (Ø260 mm)	
	17	8A00 55241	4	Vite	Screw	Vis	Schraube	Tornillo	
WU	18	8000 A2785	1	Perno ruota	Pin	Pivot	Bolzen	Perno ruoda	
C	18	8000 96932	1	Perno ruota	Pin	Pivot	Bolzen	Perno ruoda	
	19	8000 96933	1	Vite	Screw	Vis	Schraube	Tornillo	
	21	8000 96930	1	Distanziale	Spacer	Entretoise	Distanzstück	Separador	
	22	66N0 21270	1	Anello SEEGER	SEEGER ring	Anneau SEEGER	Ring SEEGER	Anillo SEEGER	
	23	8000 22966	1	Anello di tenuta (ø32xø42x7 mm)	Seal ring (ø32xø42x7 mm)	Bague d'étanchéité (ø32xø42x7 mm)	Dichtungsring (ø32xø42x7 mm)	Anillo de retención (ø32xø42x7 mm)	

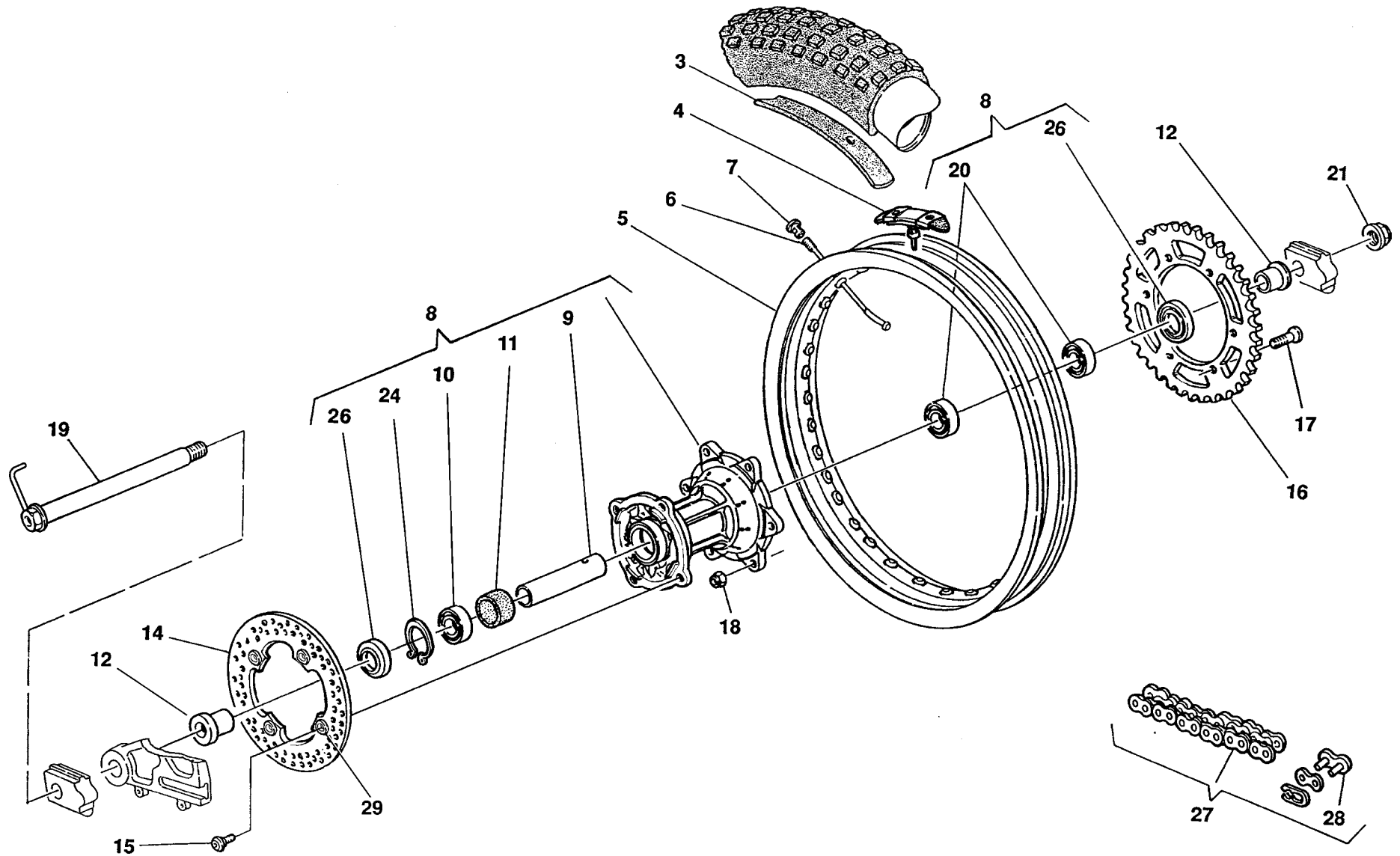

Note Notes Notas	Pos. No. N. Index Pos.	N. Cod. Code No. Nr. Code Code Nr N. Cod.	Q.tà Q.ty Q.te M.ge C.ad	DENOMINAZIONE	NAME	DESIGNATION	BESHREIBUNG	DENOMINACION	Validità Validity Validité Gültig Validez
WU	3	8000 01688	1	Fascia copriraggi	Rim strip	Bande	Band	Banda	
C	3	8000 10777	1	Fascia copriraggi	Rim strip	Bande	Band	Banda	
	4	8000 54073	1	Staffa fermacopertone	Bracket	Etrier	Buegel	Brida	
WU	5	8A00 55860	1	Cerchio (2,15 x 18")	Rim (2,15 x 18")	Jante (2,15 x 18")	Felge (2,15 x 18")	Llanta (2,15 x 18")	
C	5	8A00 58929	1	Cerchio (2,15 x 19")	Rim (2,15 x 19")	Jante (2,15 x 19")	Felge (2,15 x 19")	Llanta (2,15 x 19")	
WU	6	8000 A0085	36	Raggio	Spoke	Bras	Speiche	Radio	
C	6	8A00 A0085	36	Raggio	Spoke	Bras	Speiche	Radio	
	7	8000 A0086	36	Nipplo	Nipple	Nipple	Nippel	Nipple	
	8	8000 96937	1	Mozzo completo	Hub assy	Moyeau compl.	Radnabe, Kpl.	Cubo compl.	
	9	8000 92414	1	Distanziale	Spacer	Entretoise	Distanzstück	Separador	
	10	8B00 26846	1	Cuscinetto (ø25xø47x16 mm)	Bearing (ø25xø47x16 mm)	Roulement (ø25xø47x16 mm)	Kugellager (ø25xø47x16 mm)	Cojinete (ø25xø47x16 mm)	
	11	8000 92797	1	Porta distanziale	Spacer	Entretoise	Distanzstück	Separador	
WU	12	8000 96938	2	Distanziale	Spacer	Entretoise	Distanzstück	Separador	
C	12	8A00 96938	1	Distanziale Dx	R.h. spacer	Entretoise D.	Rechte Distanzstück	Separador derecho	
C	12	8000 96938	1	Distanziale Sx	L.h. spacer	Entretoise G.	Linke Distanzstück	Separador izquierdo	
	14	8A00 A0692	1	Disco freno (Ø220 mm)	Brake disc (Ø220 mm)	Disque frein (Ø220 mm)	Bremsscheibe (Ø220 mm)	Disco freno (Ø220 mm)	
	15	8000 62726	4	Vite	Screw	Vis	Schraube	Tornillo	
S	16	8D00 96837	1	Corona (Z = 50)	Ring gear (Z = 50)	Couronne (Z = 50)	Kranz (Z = 50)	Corona (Z = 50)	
R	16	8C00 96837	1	Corona (Z = 49)	Ring gear (Z = 49)	Couronne (Z = 49)	Kranz (Z = 49)	Corona (Z = 49)	
R	16	8E00 96837	1	Corona (Z = 51)	Ring gear (Z = 51)	Couronne (Z = 51)	Kranz (Z = 51)	Corona (Z = 51)	
R	16	8F00 96837	1	Corona (Z = 52)	Ring gear (Z = 52)	Couronne (Z = 52)	Kranz (Z = 52)	Corona (Z = 52)	
	17	8C00 40796	6	Vite (M8x25 mm)	Screw (M8x25 mm)	Vis (M8x25 mm)	Schraube (M8x25 mm)	Tornillo (M8x25 mm)	
	18	8000 43928	6	Dado	Nut	Ecrou	Mutter	Tuierca	
WU	19	8000 A2788	1	Perno	Pin	Pivot	Bolzen	Perno	
C	19	8000 96940	1	Perno	Pin	Pivot	Bolzen	Perno	
	20	8A00 26846	2	Cuscinetto (ø25xø47x12 mm)	Bearing (ø25xø47x12 mm)	Roulement (ø25xø47x12 mm)	Kugellager (ø25xø47x12 mm)	Cojinete (ø25xø47x12 mm)	
	21	8000 93072	1	Dado	Nut	Ecrou	Mutter	Tuerca	
	24	66N0 21272	1	Anello SEEGER	SEEGER ring	Anneau SEEGER	Ring SEEGER	Anillo SEEGER	
	26	8000 89572	2	Anello di tenuta (ø32xø47x7 mm)	Seal ring (ø32xø47x7 mm)	Bague d'étanchéité (ø32xø47x7 mm)	Dichtungsring (ø32xø47x7 mm)	Anillo de retención (ø32xø47x7 mm)	
WU	27	8B00 79783	1	Catena 5/8"x1/4"(114maglie)	Chain 5/8"x1/4"(114 link)	Chaîne 5/8"x1/4"(114maillon)	Kette 5/8"x1/4"(114Schake)	Cadena 5/8"x1/4"(114malla)	
WUA	27	8B00 65442	1	Catena 5/8"x1/4"(114maglie)	Chain 5/8"x1/4"(114 link)	Chaîne 5/8"x1/4"(114maillon)	Kette 5/8"x1/4"(114Schake)	Cadena 5/8"x1/4"(114malla)	
C	27	8B00 79785	1	Catena 5/8"x1/4"(114maglie)	Chain 5/8"x1/4"(114 link)	Chaîne 5/8"x1/4"(114maillon)	Kette 5/8"x1/4"(114Schake)	Cadena 5/8"x1/4"(114malla)	



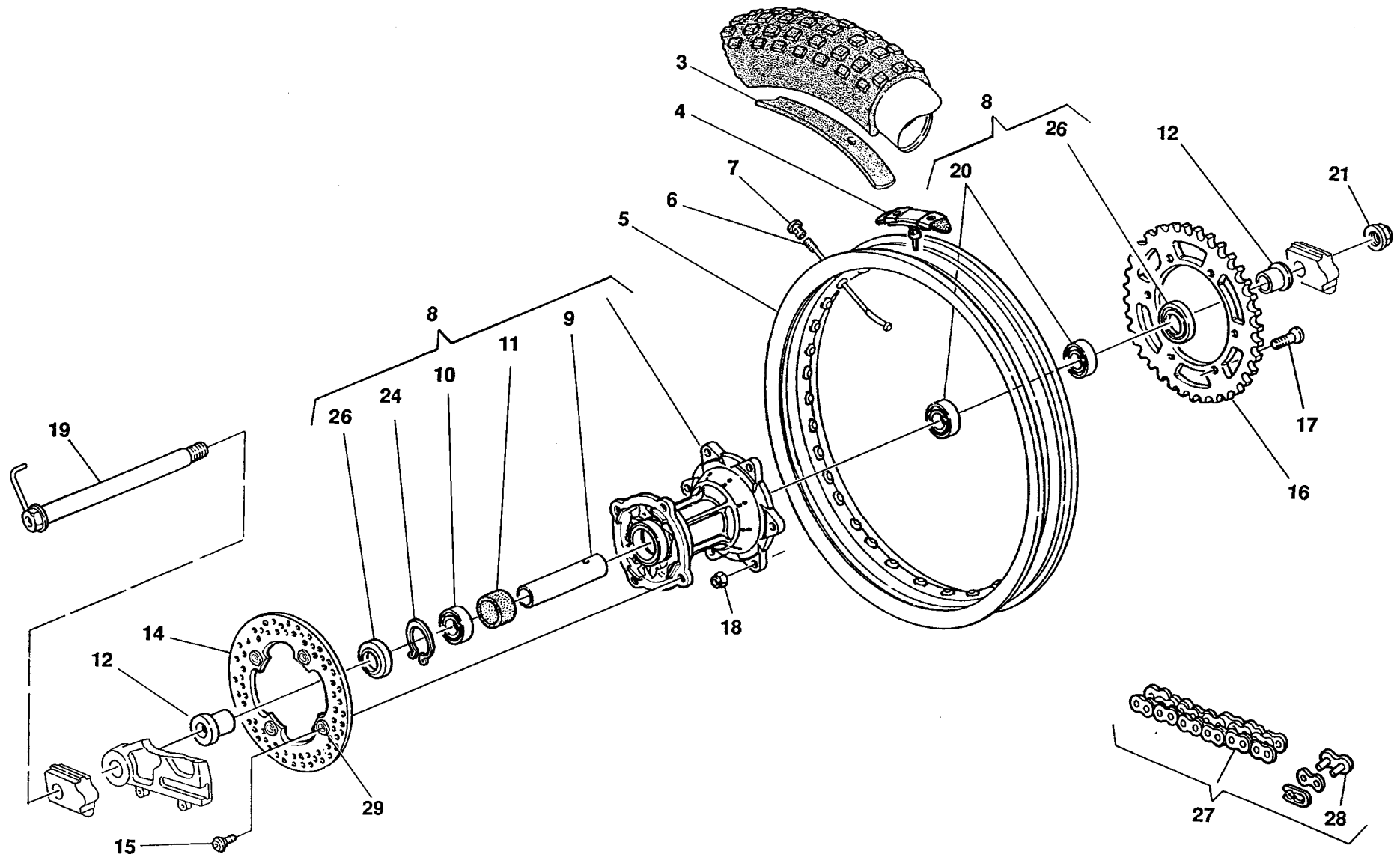



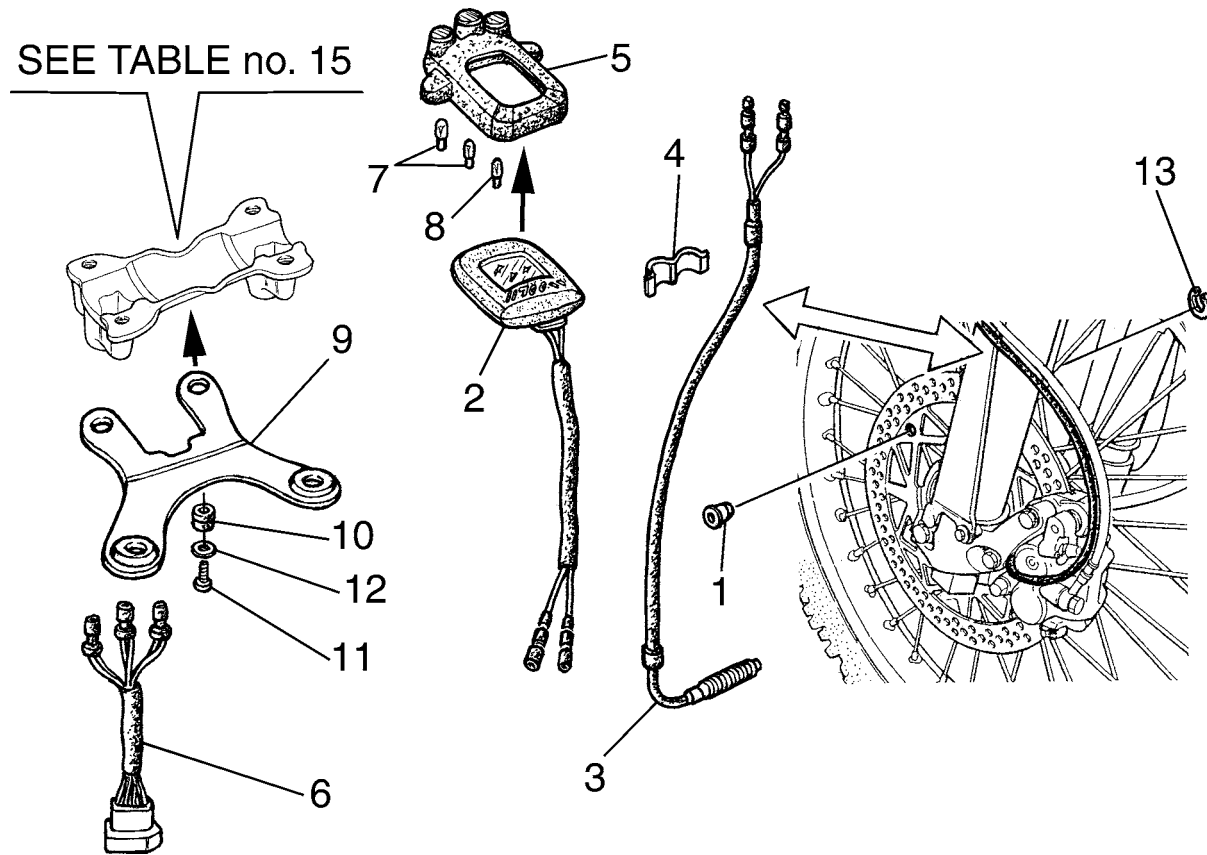



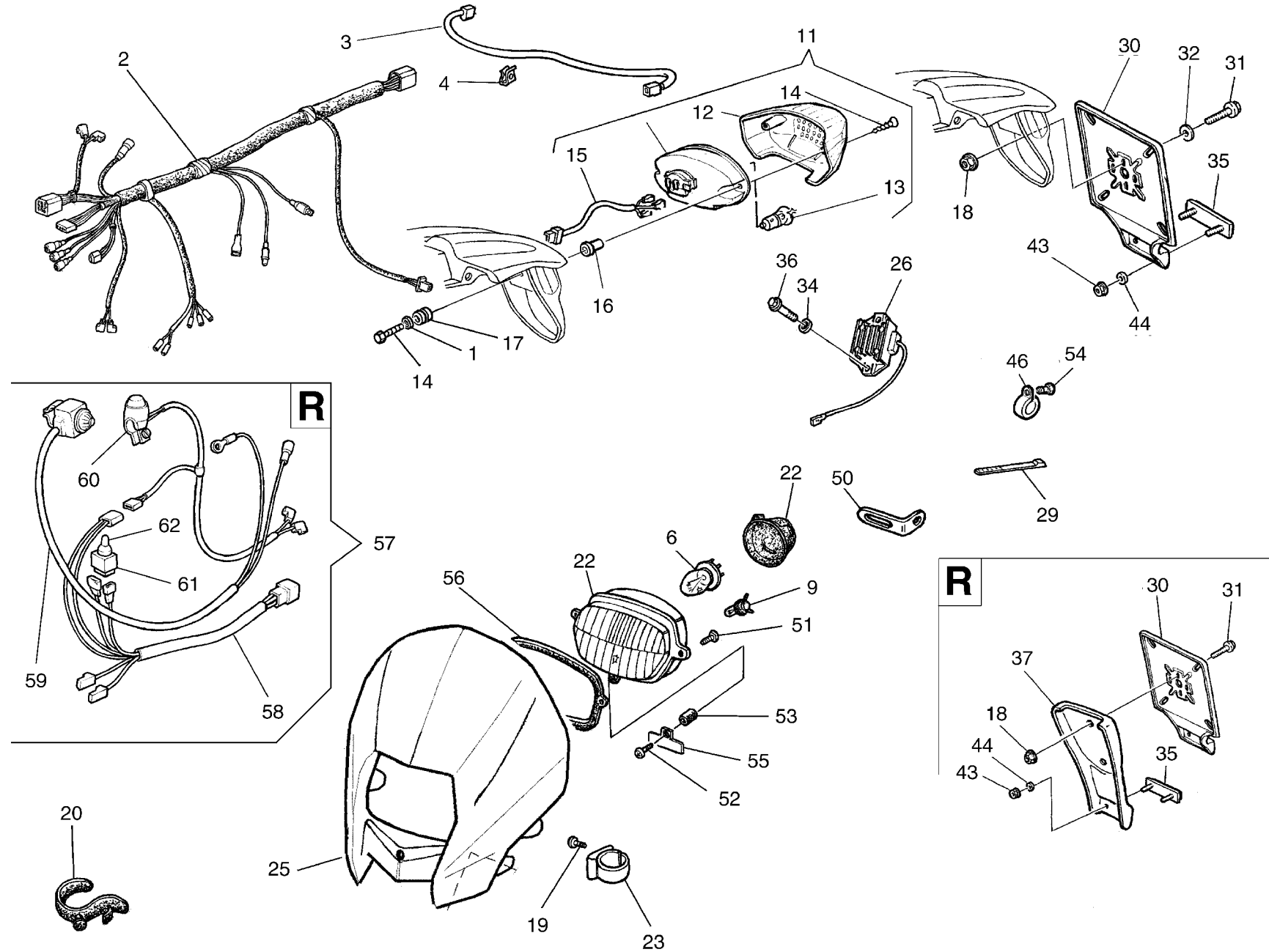

Note Notes Notes Marke Notas	Pos. No. N. Index Pos.	N. Cod. Code No. Nr. Code Code Nr N. Cod.	Q.tà Q.ty Q.te M.ge C.ad	DENOMINAZIONE	NAME	DESIGNATION	BESHREIBUNG	DENOMINACION	Validità Validity Validité Gültig Validez
X	1	8A00 20373	2	Rosetta piana	Washer	Rondelle	Scheibe	Arandela	
X	2	8000 A0713	1	Gruppo principale cavi	Cable assy	Cables compl.	Kabel Kpl.	Grupo principal cables	
X	3	8000 70277	1	Cavo posteriore	Cable	Cable	Kabel	Cable	
X	4	8000 72494	1	Passacavo	Fairlead	Passe-câble	Kabelführung	Prensa-cable	
X	6	8000 20137	1	Lampada (12V-35/35 W)	Lamp (12V-35/35 W)	Lampe (12V-35/35 W)	Lampe (12V-35/35 W)	Lamparilla (12V-35/35 W)	
X	9	8000 26694	1	Lampada (12V-3 W)	Lamp (12V-3 W)	Lampe (12V-3 W)	Lampe (12V-3 W)	Lamparilla (12V-3 W)	
X	11	8A00 88873	1	Fanale posteriore completo	Tail light	Feux arrière	Hinterleuchte	Faro trasero	
X	12	8A00 94119	1	Lente	Lens	Loupe	Linse	Lente	
X	13	8A00 18246	1	Lampada (12V-5/12 W)	Lamp (12V-5/12 W)	Lampe (12V-5/12 W)	Lampe (12V-5/12 W)	Lamparilla (12V-5/12 W)	
X	14	8000 A0953	2	Vite	Screw	Vis	Schraube	Tornillo	
X	15	8000 94121	1	Cablaggio	Cable	Cable	Kabel	Cable	
X	16	8A00 94120	2	Distanziale	Spacer	Entretoise	Distanzstück	Separador	
X	17	8000 18048	2	Gommino	Rubber pad	Pièce caoutchouc	Gummistück	Junta de goma	
X	18	8000 44240	2	Dado	Nut	Ecrou	Mutter	Tuerca	
X	19	8A00 37283	2	Vite	Screw	Vis	Schraube	Tornillo	
X	20	8000 88602	4	Elastico	Elastic	Elastique	Elastisch	Elástico	
X	22	8000 A0278	1	Gruppo ottico	Optical group	Groupe optique	Optische Gruppe	Grupo óptico	
X	23	8000 A0864	1	Anello	Ring	Bague	Ring	Anilo	
X	25	8000 A4206	1	Cupolino	Fairing	Carenage	Verkleidung	Cúpula	
	26	8000 75348	1	Regolatore di tensione	Voltage rectifier	Régulateur de tension	Spannungsregler	Regulador de tensión	
X	29	8000 56444	8	Fascetta (L=188 mm)	Clamp (L=188 mm)	Collier (L=188 mm)	Schelle (L=188 mm)	Banda (L=188 mm)	
X	30	8000 94595	1	Portatarga	Licence plate holder	Portebalai	Schildträger	Portamatrix	
X	31	8000 62727	2	Vite	Screw	Vis	Schraube	Tornillo	
X	32	8000 56359	2	Rosetta	Washer	Rondelle	Scheibe	Arandela	
X	35	8000 73834	1	Catadiottro	Reflector	Catadioptrique	Ruckstrahler	Catafaros	
	36	8000 62728	1	Vite	Screw	Vis	Schraube	Tornillo	
RX	37	8000 94342	1	Paraspruzzi (J)	Rear end (J)	Terminal (J)	Hinterkiff (J)	Para rociada (J)	
X	43	8000 40717	2	Dado	Nut	Ecrou	Mutter	Tuerca	
X	44	62N1 15547	2	Rosetta	Washer	Rondelle	Scheibe	Arandela	
	46	8000 68690	1	Fascetta	Clamp	Collier	Schelle	Banda	
	50	8AA0 55705	2	Linguetta fermacavo	Retainer	Arret	Klammer	Abrazadera de sujeción	
X	51	60N4 98033	2	Vite	Screw	Vis	Schraube	Tornillo	
X	52	8000 24962	1	Vite	Screw	Vis	Schraube	Tornillo	

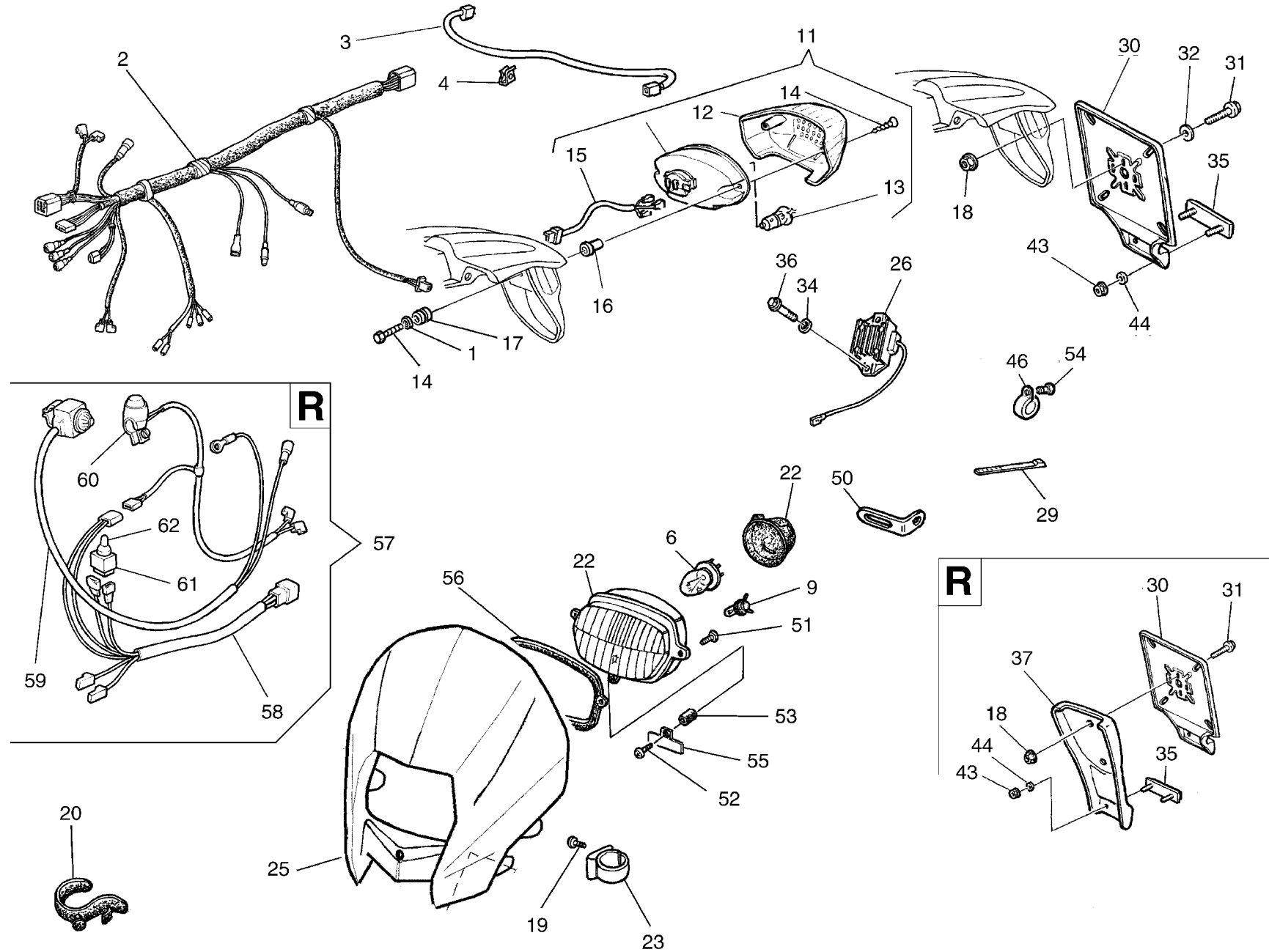





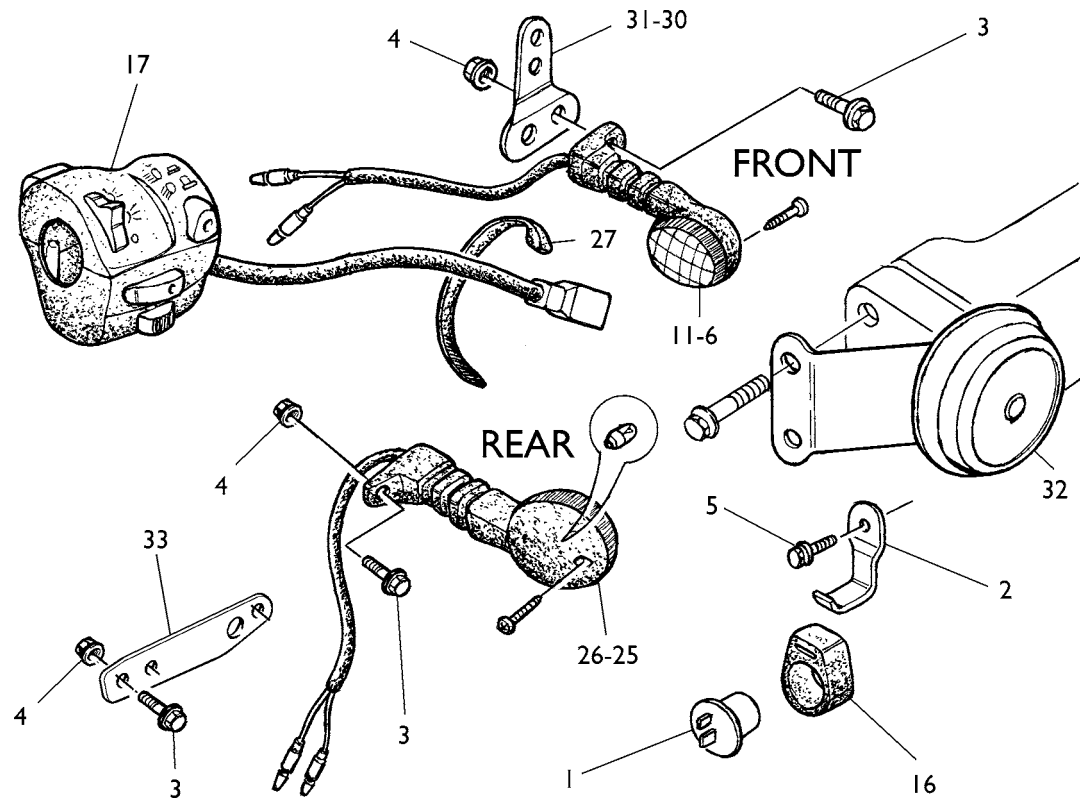



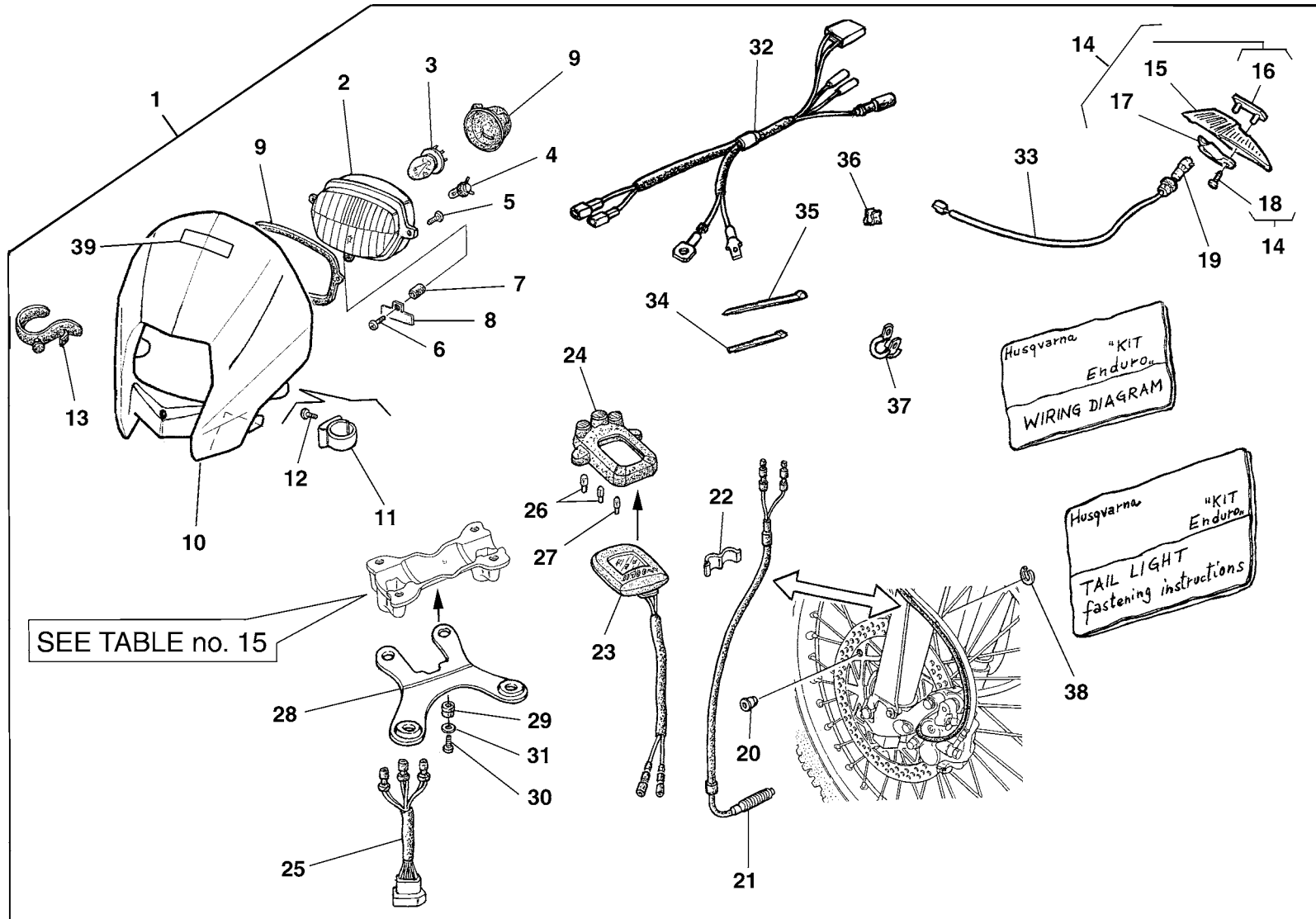

Note Notes Notas	Pos. No. N. Index Pos.	N. Cod. Code No. Nr. Code Code Nr N. Cod.	Q.tà Q.ty Q.te M.ge C.ad	DENOMINAZIONE	NAME	DESIGNATION	BESHREIBUNG	DENOMINACION	Validità Validity Validité Gültig Validez
D	1	8000 A4493	1	Kit ENDURO	ENDURO Kit	Groupe ENDURO	Gruppe ENDURO	Kit ENDURO	
	2	8000 A0278	1	Gruppo ottico	Optical group	Groupe optique	Optische Gruppe	Grupo óptico	
	3	8000 20137	1	Lampada (12V-35/35 W)	Lamp (12V-35/35 W)	Lampe (12V-35/35 W)	Lampe (12V-35/35 W)	Lamparilla (12V-35/35 W)	
	4	8000 26694	2	Lampadina (12V-3 W)	Lamp (12V-3 W)	Lampe (12V-3 W)	Lampe (12V-3 W)	Lamparilla (12V-3 W)	
	5	60N4 98033	2	Vite	Screw	Vis	Schraube	Tornillo	
	6	60N4 24962	1	Vite	Screw	Vis	Schraube	Tornillo	
	7	8000 A1051	1	Distanziale	Spacer	Entretoise	Distanzstück	Separador	
	8	8000 A1052	1	Piastrina	Plate	Plaque	Platte	Placa	
	9	8000 A4507	1	Guarnizione	Gasket	Garniture	Dichtung	Junta	
	10	8000 A4206	1	Cupolino	Fairing	Carenage .	Verkleidung	Cúpula	
	11	8000 A0864	1	Anello	Ring	Bague	Ring	Anillo	
	12	8A00 37283	2	Vite	Screw	Vis	Schraube	Tornillo	
	13	8000 88602	4	Elastico	Elastic	Elastique	Elastisch	Elástico	
	14	8000 71213	1	Fanale posteriore completo	Tail light group	Groupe feux arrière	Hinterleuchte Gruppe	Grupo faro trasero	
	15	8000 71214	1	Fanale posteriore	Tail light	Feux arrière	Hinterleuchte	Faro trasero	
	16	8000 71215	1	Fascetta	Clamp	Collier	Schelle	Banda	
	17	8000 71216	1	Protezione	Guard	Protection	Schutz	Protección	
	18	8000 71217	2	Vite	Screw	Vis	Schraube	Tornillo	
	19	8000 26694	2	Lampadina (12V-3 W)	Lamp (12V-3 W)	Lampe (12V-3 W)	Lampe (12V-3 W)	Lamparilla (12V-3 W)	
	20	8000 99775	1	Magnete	Magnet	Amiant	Magnet	Imán	
	21	8000 99652	1	Sensore magnetico	Sensor	Palpeur	Sensor	Sensor	
	22	8000 A0664	2	Molletta	Clip	Collier	Schelle	Banda	
	23	8000 99650	1	Contachilometri digitale	Digital speedometer	Compteur-km digital	Digital Tachometer	Cuenta-kilómetros digital	
	24	8000 A0883	1	Supporto spie	Holder	Support	Halterung	Soporte	
	25	8000 99651	1	Gruppo cavi	Cable assy	Cables compl.	Kabel Kpl.	Grupo cables	
	26	8000 20602	2	Lampadina (12V-1,2 W)	Lamp (12V-1,2 W)	Lampe (12V-1,2 W)	Lampe (12V-1,2 W)	Lamparilla (12V-1,2 W)	
	27	8000 60033	2	Lampadina (12V-2 W)	Lamp (12V-2 W)	Lampe (12V-2 W)	Lampe (12V-2 W)	Lamparilla (12V-2 W)	
	28	80A0 99774	1	Piastra	Plate	Plaque	Platte	Placa	
	29	8000 41862	2	Passacavo	Fairlead	Passe-câble	Kabelführung	Prensa-cable	
	30	60N4 98033	2	Vite	Screw	Vis	Schraube	Tornillo	
	31	62N4 15547	2	Rosetta	Washer	Rondelle	Scheibe	Arandela	
	32	8000 A0492	1	Gruppo cavi (ANTERIORE)	Cable assy (FRONT)	Cables compl. (AVANT)	Kabel Kpl. (VORDERE)	Grupo cables (DELANTERO)	
	33	8000 71221	1	Gruppo cavi (POSTERIORE)	Cable assy (REAR)	Cables compl. (ARRIERE)	Kabel Kpl. (HINTERE)	Grupo cables (TRASERO)	

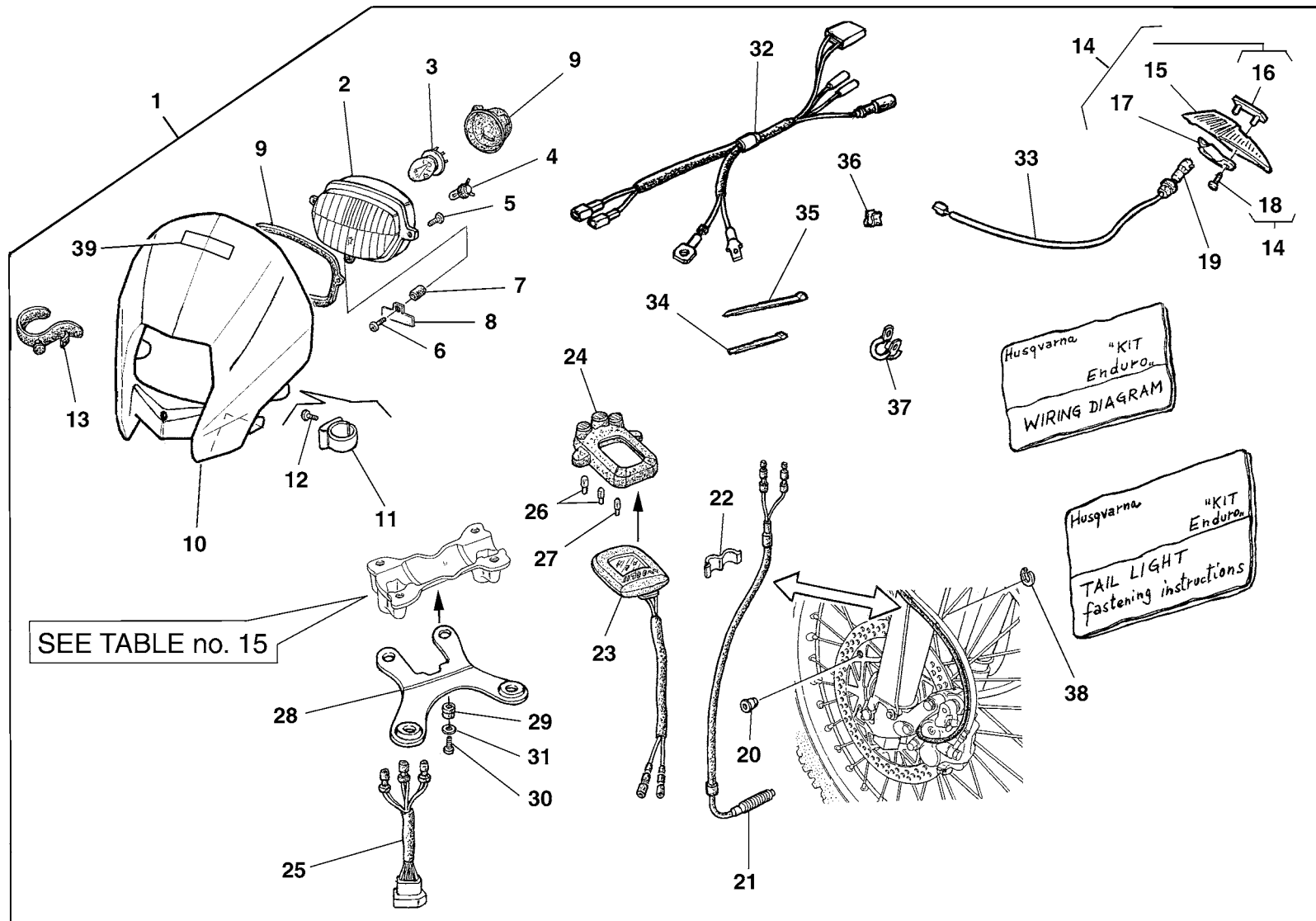













DISEGNO DRAWING DESSIN ZEICHNUNG DIBUJO	TAVOLA DRAWING TABLE BILD TABLA	INDEX NO. POS. N. INDICE	DISEGNO DRAWING DESSIN ZEICHNUNG DIBUJO	TAVOLA DRAWING TABLE BILD TABLA	INDEX NO. POS. N. INDICE	DISEGNO DRAWING DESSIN ZEICHNUNG DIBUJO	TAVOLA DRAWING TABLE BILD TABLA	INDEX NO. POS. N. INDICE	DISEGNO DRAWING DESSIN ZEICHNUNG DIBUJO	TAVOLA DRAWING TABLE BILD TABLA	INDEX NO. POS. N. INDICE	DISEGNO DRAWING DESSIN ZEICHNUNG DIBUJO	TAVOLA DRAWING TABLE BILD TABLA	INDEX NO. POS. N. INDICE	DISEGNO DRAWING DESSIN ZEICHNUNG DIBUJO	TAVOLA DRAWING TABLE BILD TABLA	INDEX NO. POS. N. INDICE
1513 07001	14	25	8000 06597	6	5	8000 36380	11	16	8000 45495	20	10	8000 59289	16	24	8000 62728	17	14
1513 41401	21	10	8000 07719	5	15	8000 36467	20	9	8000 45499	21	18	8000 59289	16	24	8000 62728	17	17
1513 74301	21	7	8000 08536	16	55	8000 36653	6	4	8000 46225	9	10	8000 59433	14	38	8000 62728	19	11
1514 10702	21	8	8000 10314	2	3	8000 36786	6	20	8000 46428	7	18	8000 59434	14	40	8000 62728	19	14
1515 50601	16	32	8000 10777	23	3	8000 37599	26	16	8000 46613	1	1	8000 59801	4	35	8000 62728	19	18
1519 84701	1	8	8000 13346	22A	3	8000 37745	20	15	8000 46893	19	5	8000 59803	4	26	8000 62728	25	36
1617 95501	3	36	8000 17810	16	21	8000 38291	10	3	8000 46893	19	20	8000 59977	5	4	8000 62729	3	37
1617 95501	4	10	8000 18048	25	17	8000 38521	16A	12	8000 47678	5	10	8000 60033	24	8	8000 62729	4	28
60N1 01059	16	60	8000 19789	3	33	8000 38706	9	5	8000 47678	5	33	8000 60033	27	27	8000 62729	6	9
60N1 01219	15	62	8000 19789	8	25	8000 38707	9	7	8000 47773	2	28	8000 60233	15	59	8000 62729	6	28
60N1 02486	2	33	8000 20137	25	6	8000 38708	9	3	8000 48814	7	2	8000 60234	15	60	8000 62729	15	40
60N1 02512	5	35	8000 20137	27	3	8000 38748	20	16	8000 48814	19	23	8000 60516	1	1	8000 62729	22	37
60N1 02514	5	37	8000 20536	16	6	8000 38797	17	12	8000 48856	5	28	8000 60873	4	20	8000 62730	9	25
60N1 02515	5	36	8000 20536	16	14	8000 39630	2	16	8000 48856	6	24	8000 61068	17	22	8000 62730	19	30
60N1 02518	5	54	8000 20536	16	61	8000 39694	6	27	8000 48916	17	16	8000 61078	18	14	8000 62730	21	6
60N1 04134	20	2	8000 20536	16	61	8000 40449	8	14	8000 48917	17	5	8000 61102	5	43	8000 62731	4	11
60N1 07335	5	53	8000 20602	24	7	8000 40717	25	43	8000 48966	17	24	8000 61313	19	4	8000 62731	16	29
60N4 24962	27	6	8000 20602	27	26	8000 40718	13	8	8000 49016	5	29	8000 61314	15	63	8000 62731	16	45
60N4 98033	25	51	8000 21480	18	25	8000 40813	20	21	8000 49036	22A	4	8000 61355	15	53	8000 62732	14	51
60N4 98033	27	5	8000 21480	22	24	8000 41240	20	20	8000 49654	22	16	8000 61355	19	16	8000 62733	22	12
60N4 98033	27	30	8000 21810	12	24	8000 41459	14	48	8000 50005	20	27	8000 62200	5	31	8000 62795	14	4
62N0 15678	5	49	8000 21939	5	7	8000 41750	5	51	8000 50629	2	8	8000 62341	21	1	8000 62795	16	36
62N1 15504	10A	5	8000 21939	5	23	8000 41862	24	10	8000 50798	17	10	8000 62675	14	55	8000 62795	16	43
62N1 15504	14	49	8000 22551	18	3	8000 41862	27	29	8000 51745	5	24	8000 62676	14	54	8000 62796	14	19
62N1 15519	5	38	8000 22966	22A	23	8000 42022	16A	16	8000 51746	5	25	8000 62725	11	19	8000 62796	15	2
62N1 15547	13	15	8000 24962	25	52	8000 42022	16B	31	8000 53155	15	61	8000 62725	16	47	8000 63312	14	39
62N1 15547	25	44	8000 26694	25	9	8000 42023	10A	7	8000 53259	18	29	8000 62725	17	31	8000 63312	16	54
62N1 15549	13	10	8000 26694	27	4	8000 42023	16A	15	8000 53259	22	20	8000 62725	18	18	8000 64296	2	27
62N4 15547	27	31	8000 26694	27	19	8000 42023	16A	17	8000 53324	5	6	8000 62725	21	20	8000 65411	16	31
62N4 15548	24	12	8000 26970	9	2	8000 42349	18	21	8000 54073	23	4	8000 62725	25	54	8000 65412	16	9
63N0 16349	7	31	8000 27960	6	21	8000 42643	5	26	8000 54507	7	27	8000 62726	13	9	8000 65437	17	21
64N1 20048	14	50	8000 28553	3	35	8000 43382	5	5	8000 55532	7	14	8000 62726	16B	24	8000 65464	23	28
64N1 20068	14	12	8000 28959	6	2	8000 43391	14	29	8000 55902	18	4	8000 62726	19	27	8000 65884	9	6
64N1 20068	18	7	8000 29089	7	16	8000 43592	20	18	8000 56359	25	32	8000 62726	19	32	8000 65921	9	24
65N0 21002	10	4	8000 30319	11	20	8000 43823	1	10	8000 56377	18	6	8000 62726	21	17	8000 65922	4	9
65N0 21002	10A	6	8000 31378	7	29	8000 43824	1	9	8000 56381	20	7	8000 62726	23	15	8000 65923	4	2
66N0 21200	24	13	8000 31744	8	24	8000 43928	14	31	8000 56443	15	72	8000 62727	6	16	8000 65935	4	4
66N0 21200	27	38	8000 31768	8	7	8000 43928	16	37	8000 56444	10	11	8000 62727	10	8	8000 65975	9	8
66N0 21203	11	11	8000 32388	16	56	8000 43928	16	44	8000 56444	10A	10	8000 62727	10A	4	8000 66238	20	3
66N0 21270	22A	22	8000 33372	13	14	8000 43928	23	18	8000 56444	25	29	8000 62727	10A	9	8000 66418	10	7
66N0 21272	23	24	8000 33373	14	20	8000 44240	10A	8	8000 56444	27	34	8000 62727	18	12	8000 66651	14	47
66NA 21208	8	22	8000 34002	27	35	8000 44240	16	33	8000 56462	4	22	8000 62727	20	24	8000 66652	14	45
6BN0 21506	7	10	8000 34451	5	32	8000 44240	16	46	8000 56767	23	28	8000 62727	25	31	8000 66802	1	4
6BN0 21506	11	18	8000 35531	14	34	8000 44240	19	31	8000 56768	23	27	8000 62727	26	3	8000 66946	11	15
8000 01199	20	17	8000 35876	9	20	8000 44240	21	21	8000 56920	1	19	8000 62728	4	13	8000 66955	8	27
8000 01412	16A	13	8000 36023	8	6	8000 44240	25	18	8000 57155	18	24	8000 62728	5	47	8000 66962	9	23
8000 01688	23	3	8000 36023	8	9	8000 44240	26	4	8000 57155	18	26	8000 62728	6	19	8000 66968	6	7
8000 03271	4	15	8000 36137	16	40	8000 45490	19	2	8000 57155	22	23	8000 62728	7	1	8000 66972	6	18
8000 03271	6	26	8000 36137	16	40	8000 45495	16	35	8000 57196	2	10	8000 62728	9	11	8000 66973	6	13
8000 06597	5	19	8000 36357	5	27	8000 45495	19	33	8000 57511	26	1	8000 62728	13	13	8000 67010	9	17

DISEGNO DRAWING DESSIN ZEICHNUNG DIBUJO	TAVOLA DRAWING TABLE BILD TABLA	INDEX NO. POS. N. INDICE	DISEGNO DRAWING DESSIN ZEICHNUNG DIBUJO	TAVOLA DRAWING TABLE BILD TABLA	INDEX NO. POS. N. INDICE	DISEGNO DRAWING DESSIN ZEICHNUNG DIBUJO	TAVOLA DRAWING TABLE BILD TABLA	INDEX NO. POS. N. INDICE	DISEGNO DRAWING DESSIN ZEICHNUNG DIBUJO	TAVOLA DRAWING TABLE BILD TABLA	INDEX NO. POS. N. INDICE	DISEGNO DRAWING DESSIN ZEICHNUNG DIBUJO	TAVOLA DRAWING TABLE BILD TABLA	INDEX NO. POS. N. INDICE	DISEGNO DRAWING DESSIN ZEICHNUNG DIBUJO	TAVOLA DRAWING TABLE BILD TABLA	INDEX NO. POS. N. INDICE
8000 67012	9	19	8000 70550	7	6	8000 74082	5	52	8000 83070	2	15	8000 86951	5	39	8000 92788	21	5
8000 67013	11	8	8000 70551	7	5	8000 74415	11	13	8000 83071	2	6	8000 86978	12	8	8000 92797	22A	12
8000 67015	11	2	8000 70552	7	12	8000 74758	6	15	8000 83073	6	1	8000 86979	12	18	8000 92797	23	11
8000 67016	11	3	8000 70554	7	13	8000 74836	5	17	8000 83085	7	3	8000 87243	14	25	8000 92817	17	7
8000 67017	11	1	8000 70635	2	17	8000 75160	16	51	8000 83087	10A	2	8000 87736	15	56	8000 92820	7	23
8000 67020	11	6	8000 70696	18	5	8000 75166	16	39	8000 83090	3	11	8000 87745	15	73	8000 92896	5	56
8000 67029	10	1	8000 70698	17	18	8000 75270	10	12	8000 83092	3	20	8000 87812	17	15	8000 93011	26	30
8000 67045	11	12	8000 70836	1	15	8000 75270	10A	12	8000 83093	3	17	8000 88231	16B	21	8000 93017	20	12
8000 67047	11	14	8000 71088	14	44	8000 75330	17	4	8000 83094	3	12	8000 88280	17	1	8000 93036	22	8
8000 67997	3	6	8000 71091	14	22	8000 75348	25	26	8000 83095	11	5	8000 88602	25	20	8000 93072	23	21
8000 67997	3	19	8000 71213	27	14	8000 75415	5	48	8000 83107	3	3	8000 88602	27	13	8000 93109	22	1
8000 67997	3	38	8000 71214	27	15	8000 76074	5	40	8000 83109	3	10	8000 88759	10	13	8000 93124	16A	6
8000 67997	5	22	8000 71215	27	16	8000 76075	5	41	8000 83110	3	9	8000 88759	10A	11	8000 93181	4	19
8000 67997	15	68	8000 71216	27	17	8000 76076	5	42	8000 83111	3	7	8000 88810	2	7	8000 93221	25	61
8000 67997	16	4	8000 71217	27	18	8000 76079	10	9	8000 83113	3	22	8000 88815	5	1	8000 93283	15	70
8000 67997	16	6	8000 71221	27	33	8000 76262	5	50	8000 83114	3	14	8000 88822	7	8	8000 93746	17	20
8000 67997	16	57	8000 71445	22	14	8000 76283	16	11	8000 83115	3	5	8000 88828	5	3	8000 93747	17	19
8000 67997	26	5	8000 71578	17	26	8000 76338	18	10	8000 83116	3	16	8000 88862	20	1	8000 93748	17	27
8000 68277	4	7	8000 71578	26	27	8000 76687	17	3	8000 83118	3	25	8000 88862	20	1	8000 93749	17	28
8000 68278	6	3	8000 71620	16	13	8000 76688	17	2	8000 83119	3	21	8000 88865	17	6	8000 93750	17	13
8000 68690	17	30	8000 71621	16	53	8000 77373	15	20	8000 83121	3	24	8000 88877	20	1	8000 93751	17	8
8000 68690	25	46	8000 71622	16	2	8000 77737	17	11	8000 83122	3	26	8000 88894	4	18	8000 93752	17	29
8000 68690	27	37	8000 71623	16	19	8000 77841	5	20	8000 83123	3	27	8000 88898	21	11	8000 93883	20	11
8000 69035	20	26	8000 71755	25	62	8000 79015	1	5	8000 83395	15	3	8000 89030	1	3	8000 94009	20	19
8000 69036	20	5	8000 71806	22	10	8000 79016	1	6	8000 84176	14	56	8000 89069	24	11	8000 94010	20	13
8000 69056	14	3	8000 72022	22	13	8000 79065	22	21	8000 84938	22A	13	8000 89089	16B	11	8000 94098	20	8
8000 69056	14	51	8000 72318	12	20	8000 79066	18	22	8000 85220	17	23	8000 89572	23	26	8000 94121	25	15
8000 69111	14	21	8000 72323	12	9	8000 79066	22	22	8000 85932	18	30	8000 89919	26	17	8000 94124	22	2
8000 69113	21	19	8000 72327	12	13	8000 79072	18	16	8000 86136	16A	5	8000 90012	10A	3	8000 94125	22	3
8000 69125	18	2	8000 72328	12	14	8000 79075	18	28	8000 86137	16A	10	8000 90107	26	32	8000 94126	22	4
8000 69148	19	15	8000 72329	12	15	8000 79077	4	25	8000 86140	16A	18	8000 90877	10	12	8000 94127	22	5
8000 69149	19	7	8000 72331	12	17	8000 79099	22	7	8000 86163	7	19	8000 90877	10A	12	8000 94128	22	6
8000 69150	14	18	8000 72494	25	4	8000 79560	2	25	8000 86166	7	28	8000 91238	16B	4	8000 94145	25	60
8000 69282	15	69	8000 72494	27	36	8000 79561	4	1	8000 86176	16A	3	8000 91288	1	12	8000 94342	25	37
8000 69282	16	52	8000 72641	13	3	8000 79789	23	28	8000 86177	16A	4	8000 91289	1	11	8000 94595	25	30
8000 69315	15	57	8000 72868	16	42	8000 79790	23	28	8000 86796	10A	1	8000 91474	15	13	8000 94652	2	22
8000 69429	13	5	8000 72869	16	41	8000 79831	1	2	8000 86838	12	1	8000 91479	15	19	8000 94849	18	26
8000 69429	16B	23	8000 72873	16	5	8000 80260	15	54	8000 86888	13	6	8000 91480	15	48	8000 94852	2	30
8000 69429	19	17	8000 72874	16	28	8000 81628	16	63	8000 86918	12	2	8000 91519	15	55	8000 95260	15	41
8000 69429	19	22	8000 72875	16	27	8000 82469	8	21	8000 86920	12	5	8000 91609	15	21	8000 95727	19	6
8000 69429	19	26	8000 72887	10A	13	8000 82496	10	2	8000 86921	12	6	8000 91965	10	10	8000 95898	13	4
8000 69429	20	23	8000 72889	5	34	8000 83010	9	1	8000 86925	12	10	8000 92149	26	17	8000 96811	15	1
8000 69549	13	2	8000 73140	14	5	8000 83033	8	5	8000 86926	12	11	8000 92215	4	36	8000 96813	15	4
8000 70024	13	7	8000 73540	10	5	8000 83034	8	18	8000 86927	12	12	8000 92216	4	24	8000 96828	17	25
8000 70216	9	14	8000 73593	10	6	8000 83043	5	46	8000 86928	12	16	8000 92248	10A	14	8000 96828	25	59
8000 70277	25	3	8000 73830	14	7	8000 83049	3	31	8000 86929	12	22	8000 92308	17	9	8000 96838	22A	10
8000 70309	7	11	8000 73832	15	82	8000 83056	2	23	8000 86930	12	23	8000 92414	23	9	8000 96897	15	4
8000 70467	7	4	8000 73834	25	35	8000 83063	2	29	8000 86932	12	7	8000 92779	2	9	8000 96907	14	6
8000 70468	7	17	8000 73893	18	23	8000 83066	2	5	8000 86933	12	21	8000 92785	2	31	8000 96908	14	11
8000 70549	7	7	8000 74016	16	38	8000 83068	2	20	8000 86950	1	2	8000 92786	2	32	8000 96912	15	50

DISEGNO DRAWING DESSIN ZEICHNUNG DIBUJO	TAVOLA DRAWING TABLE BILD TABLA	INDEX NO. POS. N. INDICE	DISEGNO DRAWING DESSIN ZEICHNUNG DIBUJO	TAVOLA DRAWING TABLE BILD TABLA	INDEX NO. POS. N. INDICE	DISEGNO DRAWING DESSIN ZEICHNUNG DIBUJO	TAVOLA DRAWING TABLE BILD TABLA	INDEX NO. POS. N. INDICE	DISEGNO DRAWING DESSIN ZEICHNUNG DIBUJO	TAVOLA DRAWING TABLE BILD TABLA	INDEX NO. POS. N. INDICE	DISEGNO DRAWING DESSIN ZEICHNUNG DIBUJO	TAVOLA DRAWING TABLE BILD TABLA	INDEX NO. POS. N. INDICE	DISEGNO DRAWING DESSIN ZEICHNUNG DIBUJO	TAVOLA DRAWING TABLE BILD TABLA	INDEX NO. POS. N. INDICE
8000 96913	15	49	8000 98786	15	6	8000 A0339	20	18	8000 A2795	16	1	8000 A4560	16B	1	8A00 55860	23	5
8000 96922	16A	1	8000 98787	15	5	8000 A0490	21	11	8000 A2803	2	21	8000 A4564	22	2	8A00 55903	18	13
8000 96928	22A	11	8000 98790	15	21	8000 A0492	27	32	8000 A2804	5	44	8000 A4565	22	3	8A00 57024	3	8
8000 96930	22A	21	8000 98792	15	22	8000 A0600	22	8	8000 A3118	21	11	8000 A4566	22	9	8A00 57446	10	13
8000 96932	22A	18	8000 98806	15	41	8000 A0633	15	51	8000 A3119	20	28	8000 A4568	22	3	8A00 57446	10A	11
8000 96933	22A	19	8000 99632	22A	16	8000 A0634	26	17	8000 A3191	15	7	8000 A4569	22	9	8A00 58929	23	5
8000 96934	22	17	8000 99650	24	2	8000 A0664	24	4	8000 A3195	28	2	8000 A4570	22	39	8A00 61261	8	4
8000 96937	23	8	8000 99650	27	23	8000 A0664	27	22	8000 A3195	29	2	8000 A4606	22	39	8A00 62797	16B	30
8000 96938	23	12	8000 99651	24	6	8000 A0678	26	2	8000 A3196	28	3	8000 A4607	19	28	8A00 65503	15	56
8000 96938	23	12	8000 99651	27	25	8000 A0693	23	29	8000 A3196	29	3	8000 A4609	19	19	8A00 65845	7	22
8000 96939	18	15	8000 99652	24	3	8000 A0713	25	2	8000 A3485	9	13	8000 A4610	19	34	8A00 65895	9	22
8000 96940	23	19	8000 99652	27	21	8000 A0801	5	44	8000 A3488	9	12	8000 A4721	28	11	8A00 66661	16	34
8000 96941	16	50	8000 99674	22	11	8000 A0804	5	57	8000 A3555	3	26	8000 A4721	29	11	8A00 66953	5	13
8000 96944	16	18	8000 99741	9	12	8000 A0864	25	23	8000 A3556	3	27	80A0 42349	20	14	8A00 67011	9	18
8000 96960	16	3	8000 99744	9	15	8000 A0864	27	11	8000 A3557	3	30	80A0 65535	19	13	8A00 67545	6	8
8000 96997	1	16	8000 99749/1	2	2	8000 A0872	4	33	8000 A3975	18	24	80A0 69551	16B	22	8A00 67545	20	4
8000 97025	16	58	8000 99749/2	2	2	8000 A0883	24	5	8000 A4098	14	2	80A0 73456	16	15	8A00 67997	3	15
8000 97615	1	20	8000 99749/3	2	2	8000 A0883	27	24	8000 A4126	29	10	80A0 73909	16	16	8A00 67997	3	32
8000 97749	15	77	8000 99753	3	1	8000 A0927	22	9	8000 A4128	28	10	80A0 74388	16	22	8A00 67997	15	52
8000 97750	15	76	8000 99755	3	30	8000 A0929	22	15	8000 A4128	29	10	80A0 89953	14	9	8A00 67997	16	23
8000 97976	14	53	8000 99756	5	44	8000 A0930	22	25	8000 A4198	19	8	80A0 89962	14	10	8A00 69282	16	26
8000 98040	14	52	8000 99758	8	1	8000 A0931	18	19	8000 A4200	19	12	80A0 91792	13	1	8A00 69315	15	57
8000 98118	15	64	8000 99759	8	11	8000 A0931	22	19	8000 A4202	19	9	80A0 99774	24	9	8A00 71086	14	37
8000 98213	5	47	8000 99761	8	3	8000 A0932	22	18	8000 A4203	19	10	80A0 99774	27	28	8A00 71087	14	46
8000 98237	15	58	8000 99763	8	19	8000 A0933	18	17	8000 A4206	25	25	80B0 43928	2	18	8A00 71154	5	2
8000 98431	1	21	8000 99765	8	13	8000 A0934	18	34	8000 A4206	27	10	80B0 73832	15	82	8A00 72334	12	19
8000 98489	16B	5	8000 99767	5	16	8000 A0953	25	14	8000 A4213	27	39	80B0 83024	4	8	8A00 73893	18	23
8000 98490	16B	7	8000 99775	24	1	8000 A1051	25	53	8000 A4214	19	12	80B0 83075	6	10	8A00 73894	18	1
8000 98491	16B	8	8000 99775	27	20	8000 A1051	27	7	8000 A4216	19	29	80B0 83076	3	34	8A00 76026	18	9
8000 98492	16B	9	8000 99817	2	1	8000 A1052	25	55	8000 A4227	28	7	80G0 69337	15	66	8A00 82469	8	21
8000 98493	16B	10	8000 99818	8	17	8000 A1052	27	8	8000 A4227	29	7	80G0 69338	15	67	8A00 83056	2	24
8000 98494	16B	12	8000 99859	22	38	8000 A1053	25	56	8000 A4228	28	6	8A00 01815	14	13	8A00 83068	2	20
8000 98495	16B	20	8000 99872	8	16	8000 A1219	25	58	8000 A4228	29	6	8A00 04883	4	3	8A00 86176	16A	11
8000 98496	16B	15	8000 99900	8	15	8000 A1686	2	21	8000 A4229	28	5	8A00 18246	25	13	8A00 86918	12	2
8000 98497	16B	16	8000 A0050	19	1	8000 A1717	2	21	8000 A4229	29	5	8A00 19946	11	9	8A00 86920	12	5
8000 98498	16B	17	8000 A0051	19	24	8000 A1804	12	4	8000 A4232	28	4	8A00 20373	25	1	8A00 86921	12	6
8000 98499	16B	18	8000 A0080	22A	8	8000 A1883	25	57	8000 A4232	29	4	8A00 23186	21	2	8A00 87717	15	3
8000 98500	16B	2	8000 A0081	22A	9	8000 A1908	8	12	8000 A4427	16A	9	8A00 25044	7	20	8A00 87810	16	10
8000 98501	16B	13	8000 A0085	23	6	8000 A1909	8	20	8000 A4429	16A	2	8A00 26846	23	20	8A00 88873	25	11
8000 98502	16B	14	8000 A0086	23	7	8000 A2352	16	64	8000 A4430	16A	7	8A00 31386	7	15	8A00 92986	22A	15
8000 98503	16B	19	8000 A0099	21	23	8000 A2773	21	23	8000 A4431	16A	19	8A00 36849	7	21	8A00 93011	26	31
8000 98509	16B	3	8000 A0099	21	23	8000 A2774	13	6	8000 A4438	1	13	8A00 37283	25	19	8A00 94119	25	12
8000 98510	16B	3	8000 A0227	26	6	8000 A2785	22A	18	8000 A4439	1	14	8A00 37283	27	12	8A00 94120	25	16
8000 98552	15	22	8000 A0228	26	11	8000 A2787	18	15	8000 A4440	1	18	8A00 37947	13	11	8A00 94356	14	57
8000 98568	16B	6	8000 A0229	26	25	8000 A2788	23	19	8000 A4493	27	1	8A00 38287	11	17	8A00 96811	15	1
8000 98569	16B	6	8000 A0230	26	26	8000 A2790	18	16	8000 A4495	22	1	8A00 40433	2	26	8A00 96895	14	1
8000 98782	15	78	8000 A0278	25	22	8000 A2791	18	17	8000 A4506	2	4	8A00 46226	9	9	8A00 96938	23	12
8000 98783	15	79	8000 A0278	27	2	8000 A2792	18	30	8000 A4507	27	9	8A00 53504	22A	6	8A00 96954	14	1
8000 98784	15	80	8000 A0300	8	10	8000 A2793	18	34	8000 A4552	22	1	8A00 55241	18	11	8A00 96959	16	1
8000 98785	15	81	8000 A0301	8	8	8000 A2794	18	35	8000 A4559	16B	1	8A00 55241	22A	17	8A00 96965	15	50



DISEGNO DRAWING DESSIN ZEICHNUNG DIBUJO	TAVOLA DRAWING TABLE BILD TABLA	INDEX NO. POS. N. INDICE	DISEGNO DRAWING DESSIN ZEICHNUNG DIBUJO	TAVOLA DRAWING TABLE BILD TABLA	INDEX NO. POS. N. INDICE	DISEGNO DRAWING DESSIN ZEICHNUNG DIBUJO	TAVOLA DRAWING TABLE BILD TABLA	INDEX NO. POS. N. INDICE	DISEGNO DRAWING DESSIN ZEICHNUNG DIBUJO	TAVOLA DRAWING TABLE BILD TABLA	INDEX NO. POS. N. INDICE	DISEGNO DRAWING DESSIN ZEICHNUNG DIBUJO	TAVOLA DRAWING TABLE BILD TABLA	INDEX NO. POS. N. INDICE	DISEGNO DRAWING DESSIN ZEICHNUNG DIBUJO	TAVOLA DRAWING TABLE BILD TABLA	INDEX NO. POS. N. INDICE
8A00 96966	15	49	8E00 48590	8	28												
8A00 97977	14	53	8E00 67997	3	29												
8A00 99475	4	17	8E00 67997	19	25												
8A00 99475	4	40	8E00 96837	23	16												
8A00 A0085	23	6	8E00 96954	14	1												
8A00 A0692	23	14	8E00 99475	5	45												
8A00 A1589	19	3	8E00 99475	13	12												
8A00 A3485	9	13	8F00 28960	4	6												
8AA0 55705	25	50	8F00 67997	3	13												
8AB0 88868	20	6	8F00 96837	23	16												
8AB0 88869	20	22	8G00 07989	8	26												
8AC0 66947	6	17	8G00 99475	5	45												
8B00 26846	23	10	8K00 69056	2	13												
8B00 43715	4	29	8L00 66179	18	20												
8B00 57022	3	4	8L00 A1804	12	4												
8B00 64988	2	12	8N00 73458	14	27												
8B00 65442	23	27	8P00 73458	14	28												
8B00 66525	15	71	8S00 67545	4	14												
8B00 67545	4	12	8S00 67545	6	25												
8B00 79783	23	27	8S00 68873	20	25												
8B00 79785	23	27	8S00 72310	12	3												
8B00 82469	8	21	8T00 72310	12	3												
8B00 83068	2	20	8U00 72310	12	3												
8B00 86918	12	2	8V00 72310	12	3												
8B00 86920	12	5	8W00 72310	12	3												
8B00 99475	4	16	8X00 72310	12	3												
8B00 A1804	12	4	8Y00 72310	12	3												
8C00 40796	23	17	8Z00 72310	12	3												
8C00 43716	4	23															
8C00 61121	16	20															
8C00 68860	8	2															
8C00 69056	15	65															
8C00 69429	19	21															
8C00 70379	21	9															
8C00 73541	21	3															
8C00 73623	13	6															
8C00 82469	8	21															
8C00 86138	16A	14															
8C00 86920	12	5															
8C00 96837	23	16															
8D00 10789	11	7															
8D00 59802	4	27															
8D00 62797	16A	8															
8D00 68860	8	2															
8D00 83068	2	20															
8D00 96837	23	16															
8E00 01049	11	10															
8E00 07989	8	26															
8E00 18282	11	4															
8E00 34292	4	5															

**CATALOGO PARTI DI RICAMBIO - PARTS CATALOG  
CATALOGUE PIECES DE RECHANGE - ERSATZTEILKATALOG  
CATALOGO PIEZAS DE REPUESTO**

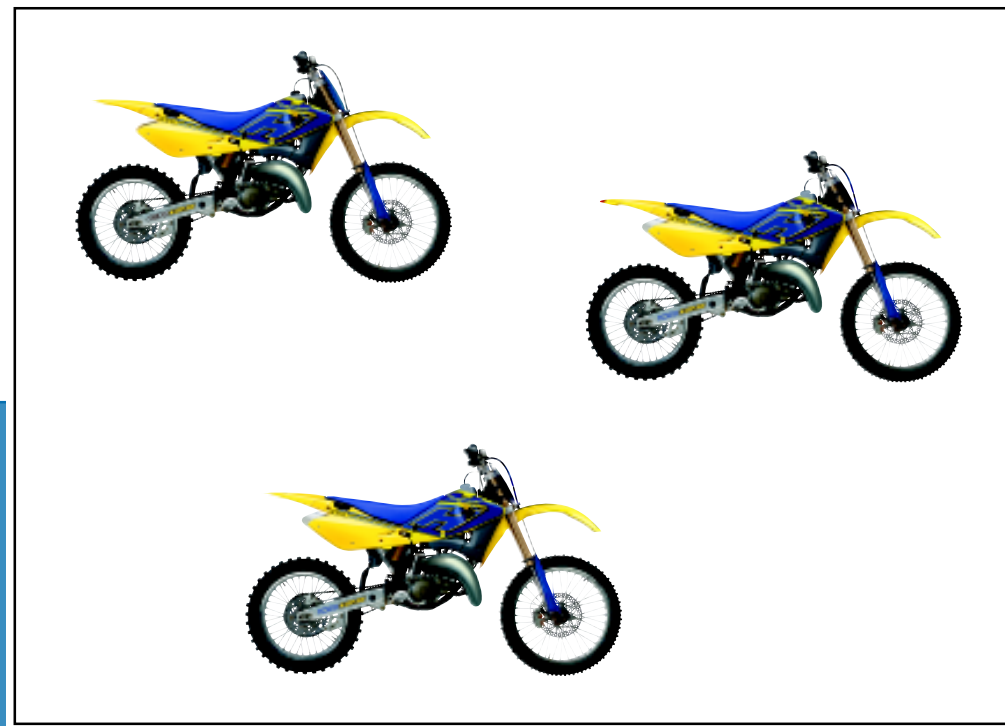

Part. N° 8000 A4440

*CR, WR, WR U.S.A. 125 / 2005*